

CCD-TR618/TR618E/TR718E/TR728E/TR818 CCD-TRV49/TRV49E/TRV58/TRV58E/TRV59E/TRV68/ TRV78/TRV78E/TRV88/TRV98/TRV98E RMT-708

SERVICE MANUAL

Self Diagnosis
Supported model

Ver 1.0 2000.12

Handycam

Handycam Vision™

video Hi8



B MECHANISM



Photo : CCD-TRV98E

US Model
CCD-TR818/TRV58/TRV68/TRV88/TRV98
Canadian Model
CCD-TR818/TRV58/TRV68/TRV98
AEP Model
UK Model
CCD-TR718E/TR728E/TRV58E/
TRV59E/TRV78E/TRV98E
E Model
CCD-TR618/TR618E/TR818/TRV49/
TRV49E/TRV58/TRV68/TRV78/
TRV78E/TRV88/TRV98/TRV98E
Australian Model
CCD-TR618E/TRV49E/TRV78E/TRV98E
Hong Kong Model
CCD-TR618E/TRV49E/TRV78E/
TRV78E/TRV98/TRV98E
Tourist Model
CCD-TRV49/TRV49E/TRV78/
TRV78E/TRV98/TRV98E
Chinese Model
CCD-TR618E/TRV49E/TRV98E
Brazilian Model
CCD-TR818/TRV58/TRV98
Argentina Model
CCD-TR818/TRV58
Korea Model
CCD-TRV49/TRV78/TRV98

NTSC model : CCD-TR618/TR818/TRV49/TRV58/
TRV68/TRV78/TRV88/TRV98
PAL model : CCD-TR618E/TR718E/TR728E/TRV49E/
TRV58E/TRV59E/TRV78E/TRV98E

For MECHANISM ADJUSTMENT, refer to
the "8mm Video MECHANICAL
ADJUSTMENT MANUAL VII" (9-973-801-11).

SPECIFICATIONS

Video camera recorder

System

Video recording system
2 rotary heads
Helical scanning FM system
Audio recording system
Rotary heads, FM system
Video signal
CCD-TR618/TR818/TRV49/TRV58/
TRV68/TRV78/TRV88/TRV98:
NTSC color, EIA standards
CCD-TR618E/TR718E/TR728E/
TRV49E/TRV58E/TRV59E/TRV78E/
TRV98E:
PAL colour, CCIR standards
Usable cassette
8mm video format cassette
Hi8 or standard 8
Recording/playback time
CCD-TR618/TR818/TRV49/TRV58/
TRV68/TRV78/TRV88/TRV98:
(using 120 min. cassette)
SP mode: 2 hours
LP mode: 4 hours
CCD-TR618E/TR718E/TR728E/
TRV49E/TRV58E/TRV59E/TRV78E/
TRV98E: (using 90 min. cassette)
SP mode: 1 hour and 30 minutes
LP mode: 3 hours
Fastforward/rewind time
CCD-TR618/TR818/TRV49/TRV58/
TRV68/TRV78/TRV88/TRV98:
(using 120 min. cassette)
CCD-TR618E/TR718E/TR728E/
TRV49E/TRV58E/TRV59E/TRV78E/
TRV98E: (using 90 min. cassette)
Approx. 5 min.

Viewfinder

Electric viewfinder
CCD-TR818: Color
CCD-TR618/TR618E/TR718E/TR728E/
TRV49/TRV49E/TRV58/TRV58E/
TRV59E/TRV68/TRV78/TRV78E/
TRV88/TRV98/TRV98E:
Monochrome
Image device
CCD-TR618/TRV49/TRV58:
3 mm (1/6 type) CCD
(Charge Coupled Device)
Approx. 270 000 pixels
(Effective: Approx. 250 000 pixels)
CCD-TR618E/TR718E/TR728E/
TRV49E/TRV58E/TRV59E:
3 mm (1/6 type) CCD
(Charge Coupled Device)
Approx. 320 000 pixels
(Effective: Approx. 290 000 pixels)
CCD-TR818/TRV68/TRV78/TRV88/
TRV98:
4.5 mm (1/4 type) CCD
(Charge Coupled Device)
Approx. 320 000 pixels
(Effective: Approx. 200 000 pixels)
CCD-TRV78E/TRV98E:
4.5 mm (1/4 type) CCD
(Charge Coupled Device)
Approx. 380 000 pixels
(Effective: Approx. 230 000 pixels)
Lens
Combined power zoom lens
Filter diameter 37 mm (1 7/16 in.)
CCD-TR618/TR618E/TRV49/
TRV49E:
20x (Optical), 450x (Digital)

CCD-TR718E/TR818/TRV58/
TRV58E/TRV68:
20x (Optical), 460x (Digital)
CCD-TR728E/TRV59E/TRV78/
TRV78E/TRV88/TRV98/TRV98E:
20x (Optical), 560x (Digital)
Focal length
3.6 - 72 mm (5/32 - 2 7/8 in.)
When converted to a 35 mm still
camera
CCD-TR618/TR618E/TR718E/
TR728E/TRV49/TRV49E/TRV58/
TRV58E/TRV59E:
51.8 - 1 036 mm (2 - 40 6/8 in.)
CCD-TR818/TRV68/TRV78/
TRV78E/TRV88/TRV98/TRV98E:
41 - 820 mm (1 5/8 - 32 3/8 in.)
Colour temperature
Auto
Minimum illumination
CCD-TR618/TR618E/TR718E/
TR728E/TRV49/TRV49E/TRV58/
TRV58E/TRV59E:
1 l x (lux) (F 1.4)
CCD-TR818/TRV68/TRV78/
TRV88/TRV98:
0.4 l x (lux) (F 1.4)
CCD-TRV78E/TRV98E:
0.3 l x (lux) (F 1.4)
0.1 x (lux) (in the NightShot mode)*
* Objects unable to be seen due to
the dark can be shot with infrared
lighting.

Output connectors

5 video output
4-pin mini DIN
Luminance signal: 1 V_{p-p},
75 Ω (ohms), unbalanced
Chrominance signal:
CCD-TR618/TR818/TRV49/TRV58/
TRV68/TRV78/TRV88/TRV98:
0.286 V_{p-p},
CCD-TR618E/TR718E/TR728E/
TRV49E/TRV58E/TRV59E/TRV78E/
TRV98E:
0.3 V_{p-p},
75 Ω (ohms), unbalanced
Audio/Video output
AV MINIJACK, 1 V_{p-p},
75 Ω (ohms), unbalanced, sync
negative
327 mV,
(at output impedance more than
47 kΩ (kilohms))
Output impedance with less than
2.2 kΩ (kilohms)/Monaural
minijack (ø 3.5 mm)
RFU DC OUT
Mini-mini jack (ø 2.5 mm), DC 5V
Earphone jack
CCD-TRV49/TRV49E/TRV58/
TRV58E/TRV59E/TRV68/TRV78/
TRV78E/TRV88/TRV98/TRV98E:
Monaural minijack (ø 3.5 mm)

— Continued on next page —

Hi8 VIDEO CAMERA RECORDER

SONY®

LCD screen

Picture

CCD-TRV49/TRV49E/TRV58/
TRV58E/TRV59E/TRV68/TRV78/
TRV78E:
6.2 cm (2.5 type)
50.3 × 37.4 mm. (2 × 11/2 in.)
CCD-TRV88:
7.5 cm (3.0 type)
61.0 × 43.8 mm (2 1/2 × 1 3/4 in.)
CCD-TRV98/TRV98E:
8.8 cm (3.5 type)
72.2 × 50.4 mm (2 7/8 × 2 in.)
Total dot number
CCD-TRV49/TRV49E/TRV58/
TRV58E/TRV59E/TRV68/TRV78/
TRV78E:
61 600 (280 × 220)
CCD-TRV88/TRV98/TRV98E:
123 200 (560 × 220)

General

Power requirements

7.2 V (battery pack)

8.4 V (AC power adaptor)

Average power consumption (when using the battery pack)

During camera recording

CCD-TR618/TR618E/TR718E/
TR728E: 2.3 W

CCD-TR818: 2.0 W

During camera recording using
LCD

CCD-TRV49/TRV49E/TRV58/
TRV58E/TRV59E/TRV68/TRV78/
TRV78E: 2.7 W

CCD-TRV88/TRV98/TRV98E: 3.4 W
Viewfinder

2.3 W

Operating temperature

0 °C to 40 °C (32 °F to 104 °F)

Recommended charging temperature

10 °C to 30 °C (50 °F to 86 °F)

Storage temperature

-20 °C to +60 °C (-4 °F to +140 °F)

Dimensions (approx.)

CCD-TR618/TR618E/TR718E/
TR728E:

104 × 105 × 223 mm
(4 1/8 × 4 1/4 × 9 1/8 in.)
(w/h/d)

CCD-TR818:

104 × 105 × 197 mm
(4 1/8 × 4 1/4 × 7 7/8 in.)
(w/h/d)

CCD-TRV49/TRV49E/TRV58/
TRV58E/TRV59E/TRV68/TRV78/
TRV78E/TRV88/TRV98/TRV98E:
104 × 109 × 223 mm
(4 1/8 × 4 3/8 × 9 1/8 in.)
(w/h/d)

Mass (approx.)

CCD-TR618/TR618E/TR718E/
TR728E:

780 g (1 lb 11 oz)

CCD-TR818:

760 g (1 lb 10 oz)

CCD-TRV49/TRV49E/TRV58/
TRV58E/TRV59E/TRV68/TRV78/
TRV78E:

910 g (2 lb)

CCD-TRV88:

920 g (2 lb)

CCD-TRV98/TRV98E:

930 g (2 lb)

excluding the battery pack, cassette
and shoulder strap

CCD-TR618/TR618E/TR718E/
TR728E:

930 g (2 lb)

CCD-TR818:

910 g (2 lb)

CCD-TRV49/TRV49E/TRV58/
TRV58E/TRV59E/TRV68/TRV78/
TRV78E/TRV88/TRV98/TRV98E:

1.1 kg (2 lb 7 oz)

including the battery pack

NP-F330, cassette and shoulder
strap

Supplied accessories

See page 3.

AC power adaptor

Power requirements

100 - 240 V AC, 50/60 Hz

Power consumption

23 W

Output voltage

DC OUT: 8.4 V, 1.5 A in operating
mode

Operating temperature

0 °C to 40 °C (32 °F to 104 °F)

Storage temperature

-20 °C to +60 °C (-4 °F to +140 °F)

Dimensions (approx.)

125 × 39 × 62 mm
(5 × 1 9/16 × 2 1/2 in.) (w/h/d)

excluding projecting parts

Mass (approx.)

280 g (9.8 oz)

excluding power cord

Battery pack

Maximum output voltage

DC 8.4 V

Output voltage

DC 7.2 V

Capacity

5.0 Wh (700mAh)

Dimensions (approx.)

38.4 × 20.6 × 70.8 mm
(1 9/16 × 13/16 × 2 7/8 in.)

(w/h/d)

Mass (approx.)

70 g (2.5 oz)

Operating temperature

0 °C to 40 °C (32 °F to 104 °F)

Type

Lithium ion

Design and specifications are
subject to change without notice.

SAFETY-RELATED COMPONENT WARNING!!

COMPONENTS IDENTIFIED BY MARK \triangle OR DOTTED LINE WITH MARK \triangle ON THE SCHEMATIC DIAGRAMS AND IN THE PARTS LIST ARE CRITICAL TO SAFE OPERATION. REPLACE THESE COMPONENTS WITH SONY PARTS WHOSE PART NUMBERS APPEAR AS SHOWN IN THIS MANUAL OR IN SUPPLEMENTS PUBLISHED BY SONY.

ATTENTION AU COMPOSANT AYANT RAPPORT À LA SÉCURITÉ!

LES COMPOSANTS IDENTIFIÉS PAR UNE MARQUE \triangle SUR LES DIAGRAMMES SCHÉMATIQUES ET LA LISTE DES PIÈCES SONT CRITIQUES POUR LA SÉCURITÉ DE FONCTIONNEMENT. NE REMPLACER CES COMPOSANTS QUE PAR DES PIÈCES SONY DONT LES NUMÉROS SONT DONNÉS DANS CE MANUEL OU DANS LES SUPPLÉMENTS PUBLIÉS PAR SONY.

SAFETY CHECK-OUT

After correcting the original service problem, perform the following safety checks before releasing the set to the customer.

1. Check the area of your repair for unsoldered or poorly-soldered connections. Check the entire board surface for solder splashes and bridges.
2. Check the interboard wiring to ensure that no wires are "pinched" or contact high-wattage resistors.
3. Look for unauthorized replacement parts, particularly transistors, that were installed during a previous repair. Point them out to the customer and recommend their replacement.
4. Look for parts which, through functioning, show obvious signs of deterioration. Point them out to the customer and recommend their replacement.
5. Check the B+ voltage to see it is at the values specified.
6. Flexible Circuit Board Repairing
 - Keep the temperature of the soldering iron around 270°C during repairing.
 - Do not touch the soldering iron on the same conductor of the circuit board (within 3 times).
 - Be careful not to apply force on the conductor when soldering or unsoldering.

• SUPPLIED ACCESSORIES

Check that the following accessories are supplied with your camcorder.

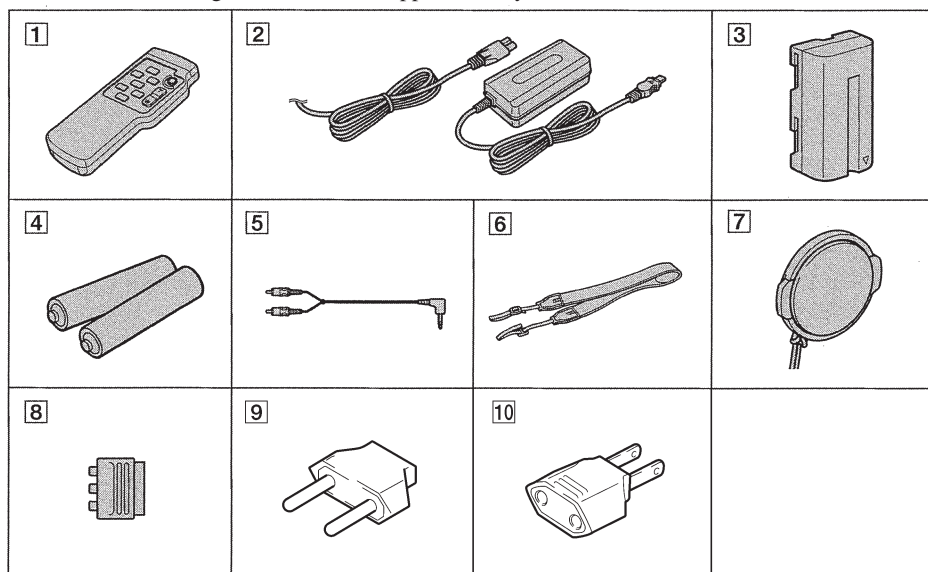

1 Wireless Remote Commander (1)
 CCD-TR728E/TRV49/TRV49E/TRV59E/
 TRV78/TRV78E/TRV98/TRV98E only

**2 AC-L10A/L10B/L10C AC power adaptor (1),
 Mains lead (1)**

3 NP-F330 battery pack (1)

**4 R6 (size AA) battery for Remote
 Commander (2)**
 CCD-TR728E/TRV49/TRV49E/TRV59E/
 TRV78/TRV78E/TRV98/TRV98E only

5 A/V connecting cable (1)

6 Shoulder strap (1)

7 Lens cap (1)

8 21-pin adaptor (1)
 CCD-TR718E/TR728E/TRV58E/TRV59E/
 TRV78E/TRV98E (European models only)

9 2-pin conversion adaptor (1)
 CCD-TRV49: JE/TRV49E: JE/TRV78: JE/
 TRV78E: JE/TRV98: JE/TRV98E: JE

10 2-pin conversion adaptor (1)
 CCD-TR618/TR618E: E,HK/TR818: E,BR/
 TRV49: E,HK/TRV49E: E,HK/TRV58: E,BR/
 TRV68: E/TRV78: E,HK/TRV78E: E,HK/
 TRV88: E/TRV98: E,HK,BR/TRV98E: E,HK

• Abbreviation

HK : Hong Kong model
 JE : Tourist model
 BR : Brazilian model

Table for difference of function

Model	CCD-TR618	CCD-TR718E	CCD-TR728E	CCD-TR818	CCD-TRV49	CCD-TRV49E	CCD-TRV58	CCD-TRV58E	CCD-TRV59E	CCD-TRV68	CCD-TRV78	CCD-TRV78E	CCD-TRV88	CCD-TRV98	CCD-TRV98E	Remark
Destination	E, HK, AUS, CN	AEP, UK	AEP, UK	US, CND, E, BR, AR	E, HK, KR, JE	E, HK, AUS, JE, CN	US, CND, E, BR, AR	AEP, UK	AEP, UK	US, CND, E	E, HK, KR, JE	AEP, UK, E, HK, AUS, JE	US, CND, E, HK, KR, JE, BR	AEP, UK, E, HK, AUS, JE, CN		
Color system	NTSC	PAL	PAL	NTSC	NTSC	PAL	NTSC	PAL	PAL	NTSC	NTSC	PAL	NTSC	PAL		
Remote commander	XX		RMT-708	XX	RMT-708		XX	RMT-708	XX	XX	RMT-708	XX	XX	RMT-708		
Optical	20x															
Lens	450x	460x	560x	460x	450x	460x	460x	560x	560x	460x	560x	560x	560x	560x		
CCD imager size	1/6 inch			1/4 inch	1/6 inch		1/6 inch		1/4 inch		1/4 inch		1/4 inch			
LCD size	XX				2.5 inch		2.5 inch		3 inch		3 inch		3.5 inch			
pixel	XX				61K		61K		123K		123K		123K			
View finder	B/W			Color	B/W		B/W		B/W		B/W		B/W			
Steady shot	XX			O	XX		XX		O		O		O			
Headphone jack	XX				XX		XX		O		O		O			
LASER LINK	XX				XX		XX		O		O		O			
Video Light	O			XX	XX		XX		O		O		O			
CD-	CD-286				CD-281		CD-281		CD-281		CD-281		CD-281			
CF-	CF-077				CF-1000 block		CF-1000 block		CF-1000 block		CF-1000 block		CF-1000 block			
Board	VF-129			VF-141	VF-129		VF-129		VF-129		VF-129		VF-129		VF-129 : B/W EVF VF-141 : Color EVF	
PD-	XX				PD-131		PD-131		PD-131		PD-131		PD-131			
MI-	MI-040				MI-041		MI-041		MI-041		MI-041		MI-041			
LB-	XX			LB-062	XX		XX		XX		XX		XX		LB-062 : Color EVF	

• Abbreviation

- CND : Canadian model
- HK : Hong Kong model
- KR : Korea model
- JE : Tourist model
- AUS : Australian model
- CN : Chinese model
- BR : Brazilian model
- AR : Argentina model

TABLE OF CONTENTS

SERVICE NOTE

- 1. POWER SUPPLY DURING REPAIRS 8
- 2. TO TAKE OUT A CASSETTE WHEN NOT EJECT
(FORCE EJECT) 8

SELF-DIAGNOSIS FUNCTION

- 1. Self-diagnosis Function 9
- 2. Self-diagnosis Display 9
- 3. Service Mode Display 9
- 3-1. Display Method 9
- 3-2. Switching of Backup No. 9
- 3-3. End of Display 9
- 4. Self-diagnosis Code Table 10

1. GENERAL

- Checking supplied accessories 1-1
- Quick Start Guide 1-1
- Getting started
 - Using this manual 1-1
 - Step 1 Preparing the power supply 1-2
 - Installing the battery pack 1-2
 - Charging the battery pack 1-2
 - Connecting to the mains 1-3
 - Step 2 Setting the date and time 1-4
 - Step 3 Inserting a cassette 1-4
- Recording –Basics 1-5
 - Recording a picture 1-5
 - Shooting backlit subjects –BACK LIGHT 1-7
 - Shooting in the dark –NightShot 1-7
 - Superimposing the date and time on pictures 1-7
 - Checking the recording –END SEARCH 1-8
- Playback –Basics 1-8
 - Playing back a tape 1-8
 - Viewing the recording on TV 1-9
- Advanced Recording Operation 1-9
 - Using the wide mode 1-9
 - Using the fader function 1-10
 - Using special effects –Picture effect 1-11
 - Using the PROGRAM AE function 1-11
 - Adjusting the exposure manually 1-12
 - Focusing manually 1-12
 - Superimposing a title 1-13
 - Making your own titles 1-13
 - Using the built-in light 1-14
- Editing 1-15
 - Dubbing a tape 1-15
- Customizing Your Camcorder 1-15
 - Changing the menu settings 1-15
- Troubleshooting 1-17
 - Types of trouble and their solutions 1-17
 - Self-diagnosis display 1-18
 - Warning indicators and messages 1-18
- Additional Information 1-19
 - Usable cassettes and playback modes 1-19
 - About “InfoLITHIUM” battery 1-19
 - Using your camcorder abroad 1-20
 - Maintenance information and precautions 1-20
- Quick Reference 1-22
 - Identifying the parts and controls 1-22

2. DISASSEMBLY

- 2-1. VIDEO LIGHT (VIDEO LIGHT MODEL) 2-2
- 2-2. LCD SECTION (PD-131 BOARD) (TRV MODEL) 2-3
- 2-3. FRONT PANEL SECTION, MI-040/041 BOARD 2-4
- 2-4. CABINET (L) SECTION 2-5

- 2-5. CABINET (R) SECTION (CF-077 BOARD)
(TR MODEL) 2-6
- 2-6. CABINET (R) SECTION [CONTROL SWITCH
BLOCK (CF-1000)] (TRV MODEL) 2-7
- 2-7. VF-129 BOARD (B/W EVF MODEL) 2-8
- 2-8. VF-141, LB-062 BOARDS
(COLOR EVF MODEL/TR818) 2-9
- 2-9. BATTERY PANEL SECTION
(BATTERY TERMINAL BOARD) 2-10
- 2-10. LENS SECTION 2-11
- 2-11. VC-251 BOARD 2-11
- 2-12. MECHANISM DECK 2-14
- 2-13. HINGE ASSEMBLY (TRV MODEL) 2-14
- 2-14. CIRCUIT BOARDS LOCATION 2-15
- 2-15. FLEXIBLE BOARDS LOCATION 2-16

3. BLOCK DIAGRAMS

- 3-1. OVERALL BLOCK DIAGRAM (1/2) 3-3
- 3-2. OVERALL BLOCK DIAGRAM (2/2) 3-5
- 3-3. CAMERA/VIDEO BLOCK DIAGRAM (1/2) 3-7
- 3-4. CAMERA/VIDEO BLOCK DIAGRAM (2/2) 3-9
- 3-5. VTR/CAMERA CONTROL BLOCK DIAGRAM 3-11
- 3-6. SERVO BLOCK DIAGRAM 3-13
- 3-7. MODE CONTROL BLOCK DIAGRAM 3-15
- 3-8. AUDIO BLOCK DIAGRAM 3-17
- 3-9. LCD BLOCK DIAGRAM 3-19
- 3-10. B/W EVF BLOCK DIAGRAM 3-21
- 3-11. COLOR EVF BLOCK DIAGRAM 3-23
- 3-12. POWER BLOCK DIAGRAM (1/2) 3-25
- 3-13. POWER BLOCK DIAGRAM (2/2) 3-27

4. PRINTED WIRING BOARDS AND SCHEMATIC DIAGRAMS

- 4-1. FRAME SCHEMATIC DIAGRAM (1/2) 4-1
- 4-1. FRAME SCHEMATIC DIAGRAM (2/2) 4-3
- 4-2. PRINTED WIRING BOARDS AND SCHEMATIC DIAGRAMS 4-5
 - CD-281/286 (CCD IMAGER)
PRINTED WIRING BOARD AND SCHEMATIC DIAGRAM 4-7
 - MI-040/041 (STEADY SHOT, MIC AMP, IR DRIVE)
PRINTED WIRING BOARD 4-9
 - MI-040/041 (STEADY SHOT, MIC AMP)(1/2)
SCHEMATIC DIAGRAM 4-11
 - MI-040/041 (IR DRIVE)(2/2)
SCHEMATIC DIAGRAM 4-13
 - PD-131 (RGB, TIMING GENERATOR, BACK LIGHT)
PRINTED WIRING BOARD 4-15
 - PD-131 (RGB, TIMING GENERATOR)(1/2)
SCHEMATIC DIAGRAM 4-19
 - PD-131 (BACK LIGHT)(2/2)
SCHEMATIC DIAGRAM 4-21
 - VF-129 (B/W EVF)
PRINTED WIRING BOARD 4-24
 - VF-129 (B/W EVF)
SCHEMATIC DIAGRAM 4-25
 - VF-141 (COLOR EVF)
PRINTED WIRING BOARD 4-27
 - VF-141 (COLOR EVF)
SCHEMATIC DIAGRAM 4-29
 - LB-062 (EVF BACK LIGHT)
PRINTED WIRING BOARD AND SCHEMATIC DIAGRAM 4-31
 - CONTROL SWITCH BLOCK (CF-1000)
SCHEMATIC DIAGRAM 4-33
 - CF-077 (SWITCH)
PRINTED WIRING BOARD 4-35

• CF-077 (SWITCH) SCHEMATIC DIAGRAM	4-37
• VC-251 (CAMERA PROCESSOR, Y/C PROCESSOR, FOCUS/ZOOM MOTOR DRIVE, REC/PB AMP, LINE I/O AMP, SERVO, MODE CONTROL, HI CONTROL, AUDIO, DC/DC CONVERTER, CONNECTOR) PRINTED WIRING BOARD	4-39
• VC-251 (CAMERA PROCESSOR AMP)(1/11) SCHEMATIC DIAGRAM	4-43
• VC-251 (Y/C PROCESSOR)(2/11) SCHEMATIC DIAGRAM	4-45
• VC-251 (FOCUS/ZOOM MOTOR DRIVE)(3/11) SCHEMATIC DIAGRAM	4-47
• VC-251 (REC/PB AMP)(4/11) SCHEMATIC DIAGRAM	4-49
• VC-251 (LINE I/O AMP)(5/11) SCHEMATIC DIAGRAM	4-51
• FP-249 (S/T REEL SENSOR, TAPE TOP), FP-356 (TAPE END), FP-355 (TAPE LED) FLEXIBLE BOARDS	4-52
• VC-251 (SERVO)(6/11) SCHEMATIC DIAGRAM	4-53
• VC-251 (MODE CONTROL)(7/11) SCHEMATIC DIAGRAM	4-55
• VC-251 (HI CONTROL)(8/11) SCHEMATIC DIAGRAM	4-57
• VC-251 (AUDIO)(9/11) SCHEMATIC DIAGRAM	4-59
• VC-251 (DC/DC CONVERTER)(10/11) SCHEMATIC DIAGRAM	4-61
• VC-251 (CONNECTOR)(11/11) SCHEMATIC DIAGRAM	4-63
• FP-257 (VIDEO LIGHT, S VIDEO) FLEXIBLE BOARD	4-65
4-3. WAVEFORMS	4-66
4-4. MOUNTED PARTS LOCATION	4-70

5. ADJUSTMENTS

1. Before starting adjustment	5-2
1-1. Adjusting items when replacing main parts and boards ..	5-2
5-1. CAMERA SECTION ADJUSTMENT	5-4
1-1. PREPARATIONS BEFORE ADJUSTMENT (CAMERA SECTION)	5-4
1-1-1. List of Service Tools	5-4
1-1-2. Preparations	5-5
1-1-3. Precaution	5-8
1. Setting the Switch	5-8
2. Order of Adjustments	5-8
3. Subjects	5-8
1-2. INITIALIZATION OF D, E, F, 7 PAGE DATA	5-9
1. Initializing the D, E, F, 7 Page Data	5-9
2. Modification of D, E, F, 7 Page Data	5-9
3. D Page Table	5-9
4. F Page table	5-10
5. E Page Table	5-12
6. 7 Page Table	5-13
1-3. CAMERA SYSTEM ADJUSTMENTS	5-14
1. Lens Type Input	5-14
2. HALL Adjustment	5-14
3. Flange Back Adjustment (Using Minipattern Box)	5-15
4. Flange Back Adjustment (Using Flange Back Adjustment Chart and Subject More Than 500m Away)	5-16
4-1. Flange Back Adjustment (1)	5-16
4-2. Flange Back Adjustment (2)	5-16
5. Flange Back Check	5-17
6. Picture Frame Setting	5-18

7. Color Reproduction Adjustment	5-19
8. Auto White Balance & LV Standard Data Input	5-20
9. Auto White Balance Adjustment	5-21
10. White Balance Check	5-22
11. Angular Velocity Sensor Sensitivity Adjustment (CCD-TR818/TRV68/TRV78/TRV78E/TRV88/TRV98/ TRV98E)	5-23
1-4. COLOR ELECTRONIC VIEWFINDER SYSTEM ADJUSTMENT (CCD-TR818)	5-24
1. RGB AMP Adjustment (VF-141 board)	5-25
2. Contrast Adjustment (VF-141 board)	5-25
3. Backlight Consumption Current Adjustment (LB-062 board)	5-26
4. White Balance Adjustment (VF-141 board)	5-26
1-5. MONOCHROME ELECTRONIC VIEWFINEDER SYSTEM ADJUSTMENT (CCD-TR618/TR618E/TR718E/TR728E/TRV49/ TRV49E/TRV58/TRV58E/TRV59E/TRV68/TRV78/ TRV78E/TRV88/TRV98/TRV98E)	5-27
1-5-1. Horizontal Slant Check	5-27
1-5-2. Centering Adjustment	5-27
1-5-3. Focus Adjustment	5-27
1-5-4. Aberration Adjustment	5-28
1-5-5. Horizontal Amplitude Adjustment (VF-129 board)	5-28
1-5-6. Vertical Amplitude Adjustment (VF-129 board)	5-29
1-5-7. Brightness Adjustment (VF-129 board)	5-29
1-5-8. Horizontal Amplitude, Vertical Amplitude, Focus Check	5-29
1-6. LCD SYSTEM ADJUSTMENT (CCD-TRV49/TRV49E/TRV58/TRV58E/TRV59E/ TRV68/TRV78/TRV78E/TRV88/ TRV98/TRV98E)	5-30
1. LCD Type Check	5-30
2. VCO Adjustment (PD-131 board)	5-31
3. RGB AMP Adjustment (PD-131 board)	5-31
4. Contrast Adjustment (PD-131 board)	5-32
5. COM AMP Adjustment (PD-131 board)	5-32
6. V-COM Adjustment (PD-131 board)	5-33
7. White Balance Adjustment (PD-131 board)	5-33
5-2. MECHANISM SECTION ADJUSTMENT	5-34
2-1. ADJUSTMENT REMOTE COMMANDER	5-34
2-2. OPERATING WITHOUT CASSETTE	5-34
2-3. TAPE PATH ADJUSTMENT	5-34
1. Preparations for Adjustment	5-34
5-3. VIDEO SECTION ADJUSTMENTS	5-35
3-1. PREPARATIONS BEFORE ADJUSTMENTS	5-35
3-1-1. Equipment to Required	5-35
3-1-2. Precautions on Adjusting	5-36
3-1-3. Adjusting Connectors	5-37
3-1-4. Connecting the Equipment	5-37
3-1-5. Alignment Tape	5-38
3-1-6. Output Level and Impedance	5-39
3-1-7. Recording Mode (Standard 8/Hi8) switching	5-39
3-2. SYSTEM CONTROL SYSTEM ADJUSTMENT	5-40
1. Initialization of D, E, F, 7 Page Data	5-40
3-3. SERVO SYSTEM ADJUSTMENT	5-40
1. CAP FG Offset Adjustment (VC-251 board)	5-40
2. Switching Position Adjustment (VC-251 Board)	5-40
3-4. VIDEO SYSTEM ADJUSTMENTS	5-41
1. 28 MHz Origin Oscillation Adjustment (VC-251 board)	5-41
2. AFC fo Adjustment (VC-251 board)	5-42
3. Filter fo Adjustment (VC-251 board)	5-42
4. Y OUT Level Adjustment (VC-251 board)	5-43
5. C OUT Level Adjustment (VC-251 board)	5-43
6. REC Y Current Adjustment (VC-251 board)	5-44
7. REC C/AFM Current Adjustment	5-45
7-1. Preparations	5-45

7-2.	REC C Current Check (VC-251 board)	5-45
7-3.	REC AFM Current Adjustment (VC-251 board)	5-46
7-4.	Processing after completed adjustment	5-46
3-5.	IR TRANSMITTER ADJUSTMENTS (CCD-TRV98) ...	5-47
1.	IR Video Carrier Frequency Adjustment (MI-041 board) ..	5-47
2.	IR Video Deviation Adjustment (MI-041 board)	5-47
3.	IR Audio Deviation Adjustment (MI-041 board)	5-48
3-6.	AUDIO SYSTEM ADJUSTMENTS	5-49
1.	1.5MHz Deviation Adjustment (VC-251 board)	5-49
2.	BPF fo Adjustment (VC-251 board)	5-49
5-4.	SERVICE MODE	5-50
4-1.	ADJUSTMENT REMOTE COMMANDER	5-50
1.	Using the Adjustment Remote Commander	5-50
2.	Precautions Upon Using the Adjustment Remote Commander	5-50
4-2.	DATA PROCESS	5-51
4-3.	SERVICE MODE	5-52
1.	Test Mode Setting	5-52
2.	Emergency Memory Address	5-53
2-1.	EMG code (Emergency code)	5-53
2-2.	MSW codes	5-54
3.	Bit Value Discrimination	5-55
4.	Switch check (1)	5-55
5.	Switch check (2)	5-55
6.	Switch check (3)	5-55
7.	Switch check (4)	5-56
8.	Record of Use check	5-56
9.	Record of Self-diagnosis check	5-57

6. REPAIR PARTS LIST

6-1.	EXPLODED VIEWS	6-1
6-1-1.	OVERALL SECTION	6-1
6-1-2.	CABINET (L) SECTION	6-2
6-1-3.	B/W EVF SECTION (TR618/TR618E/TR718E/TR728E/ TRV49/TRV49E/TRV58/TRV58E/TRV59E/TRV68/ TRV78/TRV78E/TRV88/TRV98/TRV98E)	6-3
6-1-4.	COLOR EVF SECTION (TR818)	6-4
6-1-5.	CABINET (R) SECTION	6-5
6-1-6.	LCD SECTION (TRV MODEL)(TRV49/TRV49E/ TRV58/TRV58E/TRV59E/TRV68/TRV78/TRV78E/ TRV88/TRV98/TRV98E)	6-6
6-1-7.	LENS SECTION	6-7
6-1-8.	CASSETTE COMPARTMENT ASSEMBLY	6-8
6-1-9.	LS CHASSIS BLOCK ASSEMBLY	6-9
6-1-10.	MECHANISM CHASSIS ASSEMBLY	6-10
6-2.	ELECTRICAL PARTS LIST	6-11

* Color reproduction frame is shown on page 239.

SELF-DIAGNOSIS FUNCTION

1. Self-diagnosis Function

When problems occur while the unit is operating, the self-diagnosis function starts working, and displays on the viewfinder or LCD or Display window what to do. This function consists of two display; self-diagnosis display and service mode display.

Details of the self-diagnosis functions are provided in the Instruction manual.

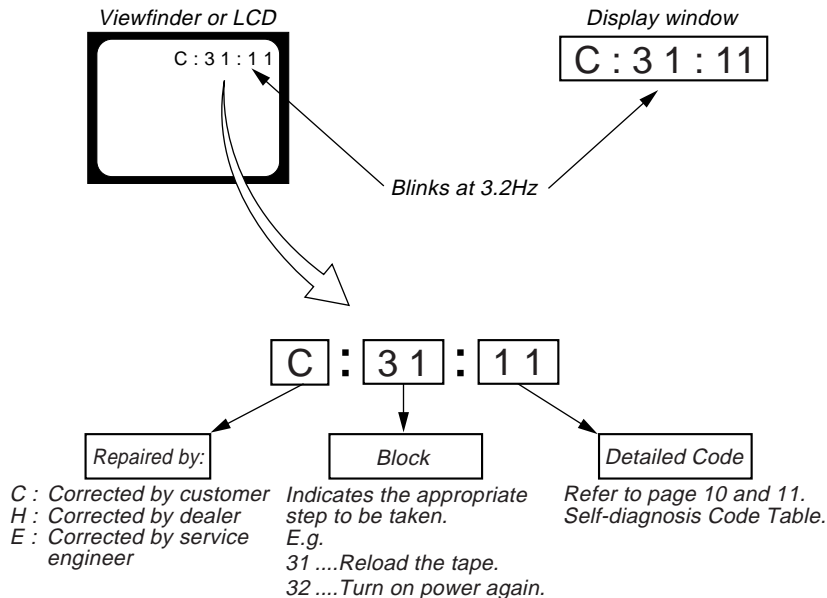

2. Self-diagnosis Display

When problems occur while the unit is operating, the counter of the viewfinder or LCD or Display window shows a 4-digit display consisting of an alphabet and numbers, which blinks at 3.2 Hz. This 5-character display indicates the “repaired by:”, “block” in which the problem occurred, and “detailed code” of the problem.

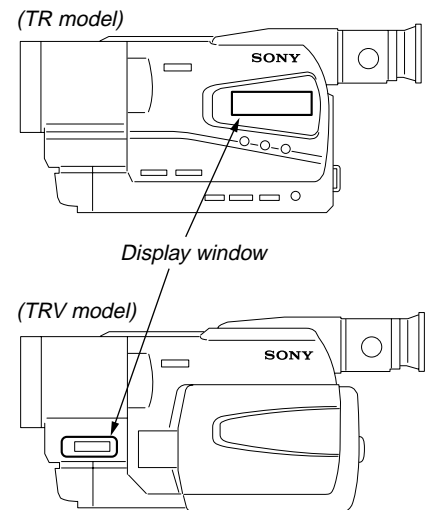

3. Service Mode Display

The service mode display shows up to six self-diagnosis codes shown in the past.

3-1. Display Method

While pressing the “STOP” key, set the switch from OFF to “VTR or PLAYER”, and continue pressing the “STOP” key for 5 seconds continuously. The service mode will be displayed, and the counter will show the backup No. and the 5-character self-diagnosis codes.

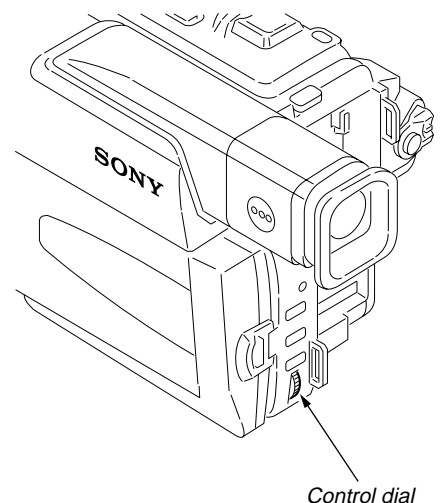
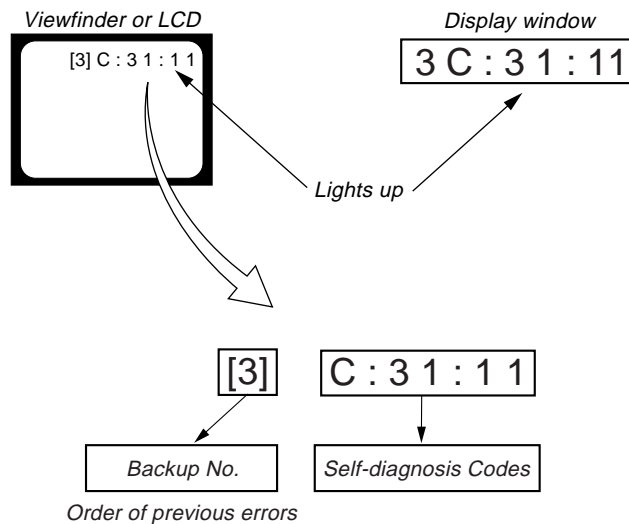

3-2. Switching of Backup No.

By rotating the control dial, past self-diagnosis codes will be shown in order. The backup No. in the [] indicates the order in which the problem occurred. (If the number of problems which occurred is less than 6, only the number of problems which occurred will be shown.)

- | | |
|----------------------------|------------------------------|
| [1] : Occurred first time | [4] : Occurred fourth time |
| [2] : Occurred second time | [5] : Occurred fifth time |
| [3] : Occurred third time | [6] : Occurred the last time |

3-3. End of Display

Turning OFF the power supply will end the service mode display.

Note: The “self-diagnosis display” data will be backed up by the built-in rechargeable lithium battery (CF-1000 block/CF-077 board BT101). When the cabinet (R) assembly is disconnected, the “self-diagnosis display” data will be lost by initialization.

4. Self-diagnosis Code Table

Self-diagnosis Code				Symptom/State	Correction
Repaired by:	Block Function	Detailed Code			
C	0 4	0 0		Non-standard battery is used.	Use the InfoLITHIUM battery.
C	2 1	0 0		Condensation.	Remove the cassette, and insert it again after one hour.
C	2 2	0 0		Video head is dirty.	Clean with the optional cleaning cassette.
C	3 1	1 0		LOAD direction. Loading does not complete within specified time	Load the tape again, and perform operations from the beginning.
C	3 1	1 1		UNLOAD direction. Loading does not complete within specified time	Load the tape again, and perform operations from the beginning.
C	3 1	2 0		T reel side tape slacking when unloading.	Load the tape again, and perform operations from the beginning.
C	3 1	2 1		S reel side tape slacking when unloading.	Load the tape again, and perform operations from the beginning.
C	3 1	2 2		T reel fault.	Load the tape again, and perform operations from the beginning.
C	3 1	2 3		S reel fault.	Load the tape again, and perform operations from the beginning.
C	3 1	3 0		FG fault when starting capstan.	Load the tape again, and perform operations from the beginning.
C	3 1	3 1		FG fault during normal capstan operations.	Load the tape again, and perform operations from the beginning.
C	3 1	4 0		FG fault when starting drum.	Load the tape again, and perform operations from the beginning.
C	3 1	4 1		PG fault when starting drum.	Load the tape again, and perform operations from the beginning.
C	3 1	4 2		FG fault during normal drum operations.	Load the tape again, and perform operations from the beginning.
C	3 1	4 3		PG fault during normal drum operations.	Load the tape again, and perform operations from the beginning.
C	3 1	4 4		Phase fault during normal drum operations.	Load the tape again, and perform operations from the beginning.
C	3 2	1 0		LOAD direction loading motor time-out.	Remove the battery or power cable, connect, and perform operations from the beginning.
C	3 2	1 1		UNLOAD direction loading motor time-out.	Remove the battery or power cable, connect, and perform operations from the beginning.
C	3 2	2 0		T reel side tape slacking when unloading.	Remove the battery or power cable, connect, and perform operations from the beginning.
C	3 2	2 1		S reel side tape slacking when unloading.	Remove the battery or power cable, connect, and perform operations from the beginning.
C	3 2	2 2		T reel fault.	Remove the battery or power cable, connect, and perform operations from the beginning.
C	3 2	2 3		S reel fault.	Remove the battery or power cable, connect, and perform operations from the beginning.
C	3 2	3 0		FG fault when starting capstan.	Remove the battery or power cable, connect, and perform operations from the beginning.
C	3 2	3 1		FG fault during normal capstan operations.	Remove the battery or power cable, connect, and perform operations from the beginning.
C	3 2	4 0		FG fault when starting drum.	Remove the battery or power cable, connect, and perform operations from the beginning.
C	3 2	4 1		PG fault when starting drum.	Remove the battery or power cable, connect, and perform operations from the beginning.
C	3 2	4 2		FG fault during normal drum operations.	Remove the battery or power cable, connect, and perform operations from the beginning.
C	3 2	4 3		PG fault during normal drum operations.	Remove the battery or power cable, connect, and perform operations from the beginning.
C	3 2	4 4		Phase fault during normal drum operations.	Remove the battery or power cable, connect, and perform operations from the beginning.

Self-diagnosis Code			Symptom/State	Correction
Repaired by:	Block Function	Detailed Code		
E	6 1	0 0	Difficult to adjust focus (Cannot initialize focus.)	Inspect the lens block focus reset sensor (Pin ⑫ of CN301 of VC-251 board) when focusing is performed when the control dial is rotated in the focus manual mode and the focus motor drive circuit (IC301 of VC-251 board) when the focusing is not performed.
E	6 1	1 0	Zoom operations fault (Cannot initialize zoom lens.)	Inspect the lens block zoom reset sensor (Pin ⑭ of CN301 of VC-251 board) when zooming is performed when the zoom lens is operated and the zoom motor drive circuit (IC301 of VC-251 board) when zooming is not performed.
E	6 2	0 0	Handshake correction function does not work well. (With pitch angular velocity sensor output stopped.)	Inspect pitch angular velocity sensor (SE751 of MI-040/041 board) peripheral circuits. *1
E	6 2	0 1	Handshake correction function does not work well. (With yaw angular velocity sensor output stopped.)	Inspect yaw angular velocity sensor (SE752 of MI-040/041 board) peripheral circuits. *1

*1: STEADY SHOT model (CCD-TR818/TRV68/TRV78/TRV78E/TRV88/TRV98/TRV98E)

SECTION 1
GENERAL

This section is extracted from instruction manual. (CCD-TRV49E/TRV58E/TRV59E/TRV78E/TRV98E model)

Checking supplied accessories

Make sure that the following accessories are supplied with your camcorder.

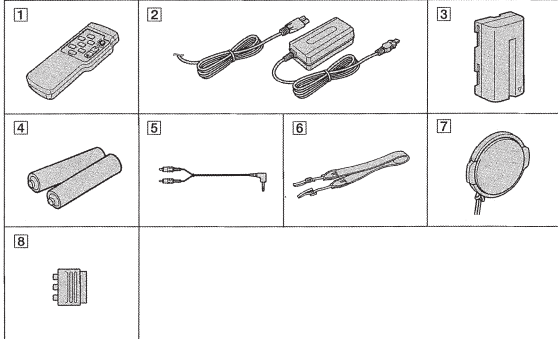

- 1 Wireless Remote Commander (1) (p. 116)
CCD-TRV49E/TRV59E/TRV78E/TRV98E only
- 2 AC-L10A/L10B/L10C AC power adaptor (1), Mains lead (1) (p. 15)
- 3 NP-F330 battery pack (1) (p. 14, 15)
- 4 R6 (size AA) battery for Remote Commander (2) (p. 116)
CCD-TRV49E/TRV59E/TRV78E/TRV98E only
- 5 A/V connecting cable (1) (p. 42)
- 6 Shoulder strap (1) (p. 112)
- 7 Lens cap (1) (p. 26, 113)
- 8 21-pin adaptor (1) (p. 43)
CCD-TRV58E/TRV59E/TRV78E/TRV98E (European models only)

Contents of the recording cannot be compensated if recording or playback is not made due to a malfunction of the camcorder, storage media, etc.

Проверка прилагаемых принадлежностей

Убедитесь, что следующие принадлежности прилагаются к Вашей видеокамере.

- 1 Беспроводный пульт дистанционного управления (1) (стр. 116)
Только модели CCD-TRV49E/TRV59E/TRV78E/TRV98E
- 2 Сетевой адаптер переменного тока AC-L10A/L10B/L10C (1), Провод электропитания (1) (стр. 15)
- 3 Батарейный блок NP-F330 (1) (стр. 14, 15)
- 4 Батарейка R6 (размера AA) для пульта дистанционного управления (2) (стр. 116)
Только модели CCD-TRV49E/TRV59E/TRV78E/TRV98E
- 5 Соединительный кабель аудио/видео (1) (стр. 42)
- 6 Плечевой ремень (1) (стр. 112)
- 7 Колпачок объектива (1) (стр. 26, 113)
- 8 21-штырьковый адаптер (1) (стр. 43)
CCD-TRV58E/TRV59E/TRV78E/TRV98E (Только европейские модели)

Содержание записи не может быть компенсировано в случае, если запись или воспроизведение не выполнены из-за неисправности видеокамеры, носителя записи и т.п.

English

Quick Start Guide



This chapter introduces you to the basic features of your camcorder. See the page in parentheses "()" for more information.

1 Connecting the mains lead (p. 20)

Use the battery pack when using your camcorder outdoors (p. 14).

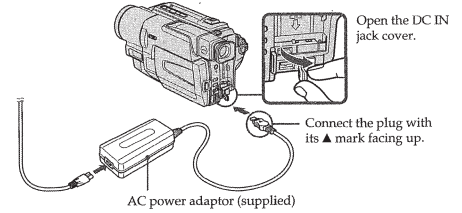

2 Inserting a cassette (p. 24)

- 1 Open the lid of the cassette compartment, and press EJECT. The compartment opens automatically.
- 2 Insert a cassette into the cassette compartment with its window facing out and the write-protect tab on the cassette up.
- 3 Close the cassette compartment by pressing the **SHUT** mark on the cassette compartment. The cassette compartment automatically goes down. Close the lid of the cassette compartment.

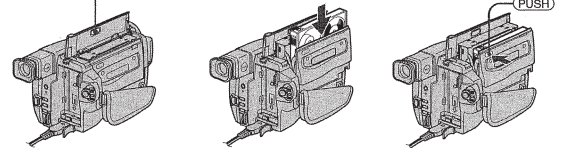

3 Recording a picture (p. 26)

- 1 Remove the lens cap.
 - 2 Set the POWER switch to CAMERA while pressing the small green button.
 - 3 Open the LCD panel while pressing OPEN. The picture appears on the LCD screen.
 - 4 Press the red button. Your camcorder starts recording. To stop recording, press the red button again.
- Viewfinder**
When the LCD panel is closed, use the viewfinder placing your eye against its eyecup. The picture in the viewfinder is black and white.

When you purchase your camcorder, the clock setting is set to off. If you want to record the date and time for a picture, set the clock setting before recording (p. 22)

4 Monitoring the playback picture on the LCD screen (p. 38)

- 1 Set the POWER switch to PLAYER while pressing the small green button.
- 2 Press **REW** to rewind the tape.
- 3 Press **PLAY** to start playback.

NOTE
Do not pick up your camcorder by holding the viewfinder, the LCD panel or the battery pack.



— Getting started —
Using this manual

The instructions in this manual are for the five models listed in the table below. Before you start reading this manual and operating your camcorder, check the model number by looking at the bottom of your camcorder. The CCD-TRV98E is the model used for illustration purposes. Otherwise, the model name is indicated in the illustrations. Any differences in operation are clearly indicated in the text, for example, "CCD-TRV98E only." As you read through this manual, buttons and settings on your camcorder are shown in capital letters. e.g. Set the POWER switch to CAMERA. When you carry out an operation, you can hear a beep sound to indicate that the operation is being carried out.

— Подготовка к эксплуатации —
Использование данного руководства

Инструкция в данном руководстве относится к четырем моделям, перечисленным в таблице на следующей странице. Прежде, чем приступить к ознакомлению с данным руководством и эксплуатации Вашей видеокамеры, проверьте номер модели с нижней стороны видеокамеры. Для иллюстративных целей используется модель CCD-TRV98E. В противном случае название модели указывается на рисунках. Всекие отличия в работе четко указываются в тексте, например, "только модель CCD-TRV98E". При чтении данного руководства учитывайте, что кнопки и установки на видеокамере показаны заглавными буквами. Прим. Установите выключатель POWER в положение CAMERA. При выполнении операции на видеокамере Вы сможете услышать зуммерный сигнал, подтверждающий выполнение операции.

Types of differences/Типы отличий

CCD-	TRV49E	TRV58E	TRV59E	TRV78E	TRV98E
Digital zoom/ Цифровой varioобъектив	450x	460x	560x	560x	560x
Remote sensor/ Дистанционный датчик	●	—	●	●	●
SteadyShot/ Дистанционный датчик	—	—	—	●	●

● Provided/Прилагается
— Not provided/Не прилагается

Note on TV colour systems

TV colour systems differ from country to country. To view your recordings on a TV, you need a PAL system-based TV.

Примечание по системам цветного телевидения

Системы цветного телевидения отличаются в зависимости от страны. Для просмотра Ваших записей на экране телевизора Вам необходимо использовать телевизор, основанный на системе PAL.

Quick Start guide

7

8

Quick Start guide

9

12

Using this manual

Precautions on camcorder care

Lens and LCD screen/finder (on mounted models only)

- The LCD screen and the finder are manufactured using extremely high-precision technology so over 99.99% of the pixels are operational for effective use. However, there may be some tiny black points and/or bright points (white, red, blue or green in colour) that constantly appear on the LCD screen and the finder. These points are normal in the manufacturing process and do not affect the recording in any way.
- Do not let your camcorder get wet. Keep your camcorder away from rain and sea water. Letting your camcorder get wet may cause your camcorder to malfunction. Sometimes this malfunction cannot be repaired [a].
- Never leave your camcorder exposed to temperatures above 60°C (140°F), such as in a car parked in the sun or under direct sunlight [b].
- Be careful when placing the camera near a window or outdoors. Exposing the LCD screen, the finder or the lens to direct sunlight for long periods may cause malfunctions [c].
- Do not directly shoot the sun. Doing so might cause your camcorder to malfunction. Take pictures of the sun in low light conditions such as dusk [d].

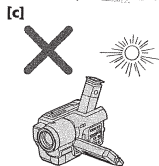

Использование данного руководства

Меры предосторожности при уходе за видеокамерой

Объектив и экран ЖКД/видискатель (только на определенных моделях)

- Экран ЖКД и искатель изготовлены с помощью чрезвычайно высокоточной технологии таким образом, что свыше 99.99% пикселей предназначено для эффективного использования. Однако, на экране ЖКД и искателя могут постоянно появляться мелкие черные и/или яркие точки (белого, красного, синего или зеленого цвета). Появление этих точек вполне нормально для процесса съемки и никоим образом не влияет на записываемое изображение.
- Не допускайте, чтобы видеокамера становилась влажной. Предохраняйте видеокамеру от дождя и морской воды. Если вы намокнули видеокамеру, то это может привести к неисправности аппарата, которая не всегда может быть устранена [a].
- Никогда не оставляйте видеокамеру в месте с температурой выше 60°C (140°F), как, например, в автомобиле, оставленном на солнце или под прямыми солнечными лучами [b].
- Помещая фотоаппарат вблизи окна или на открытом воздухе, соблюдайте осторожность. Попадание на экран ЖКД, искатель или объектив прямого солнечного света в течение длительного времени может быть причиной неисправностей [c].
- Не выполняйте съемку солнца непосредственно. Это может привести к неисправности Вашей видеокамеры. Выполняйте съемку изображений солнца в условиях слабой освещенности, как например, в сумерках [d].

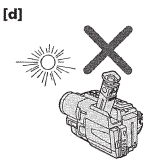
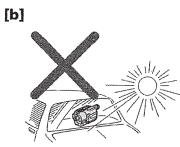

Getting started

Подготовка к эксплуатации

13

14

Step 1 Preparing the power supply

Charging the battery pack

Use the battery pack after charging it for your camcorder.

Your camcorder operates only with the "InfoLITHIUM" battery pack (L series). See page 95 for more information about "InfoLITHIUM" battery pack.

- Open the DC IN jack cover and connect the AC power adaptor supplied with your camcorder to the DC IN jack with the plug's ▲ mark facing up.
- Connect the mains lead to the AC power adaptor.
- Connect the mains lead to the mains.
- Set the POWER switch to OFF (CHARGE). Charging begins, and the CHG lamp is lit.

When the CHG lamp goes out, the charging is completed.

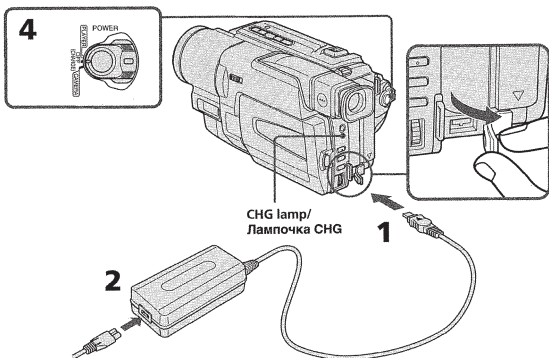

After charging the battery pack

Disconnect the AC power adaptor from the DC IN jack on your camcorder.

Пункт 1 Подготовка источника питания

Зарядка батарейного блока

Используйте батарейный блок для Вашей видеокамеры после его зарядки. Ваша видеокамера работает только с батарейным блоком "InfoLITHIUM" (серии L). Более подробные сведения о батарейном блоке "InfoLITHIUM" приведены на стр. 95.

- Откройте крышку гнезда DC IN и подсоедините сетевой адаптер переменного тока, прилагаемый к Вашей видеокамере, к гнезду DC IN, так чтобы штекер ▲ был направлен вверх.
- Подсоедините провод электропитания к сетевому адаптеру переменного тока.
- Подсоедините провод электропитания к сетевой розетке.
- Установите переключатель POWER в положение OFF(CHARGE). Начнется зарядка, и лампочка CHG загорится.

Когда лампочка CHG погаснет, зарядка завершится.

Getting started

Подготовка к эксплуатации

15

16

Step 1 Preparing the power supply

Installing the battery pack

Install the battery pack to use your camcorder outdoors.

Slide the battery pack down until it clicks.

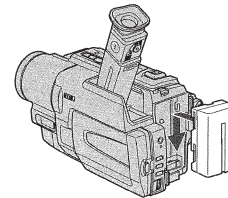

To remove the battery pack

Slide the battery pack out in the direction of the arrow while pressing ↓ BATT RELEASE down.

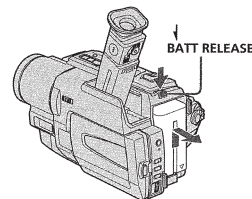

Пункт 1 Подготовка источника питания

Установка батарейного блока

Установите батарейный блок для того, чтобы использовать Вашу видеокамеру вне помещения.

Передвиньте батарейный блок вниз, чтобы он защелкнулся на месте.

Для снятия батарейного блока

Передвиньте батарейный блок в направлении стрелки, нажав кнопку ↓ BATT RELEASE вниз.

Step 1 Preparing the power supply

Notes

Prevent metallic objects from coming into contact with the metal parts of the DC plug of the AC power adaptor. This may cause a short-circuit, damaging the AC power adaptor.

- Keep the battery pack dry.
- When the battery pack is not to be used for a long time, charge the battery pack fully, and then use it until it fully discharges again. Do this once a year. Keep the battery pack in a cool place.

While charging the battery pack, the CHG lamp does not light up in the following cases

- The battery pack is not installed correctly.
- Something is wrong with the battery pack.

If the power may go off although the battery remaining indicator indicates that the battery pack has enough power to operate

Charge the battery pack fully again so that the indication on the battery remaining indicator is correct.

Пункт 1 Подготовка источника питания

Примечания

Не допускайте контакта металлических предметов с металлическими частями адаптера переменного тока. Это может привести к короткому замыканию и повреждению сетевого адаптера переменного тока.

- Храните батарейный блок в сухом состоянии.
- Если батарейный блок предполагается не использовать длительный период времени, зарядите батарейный блок полностью, а затем используйте до тех пор, пока он снова полностью не разрядится. Выполняйте это раз в год. Храните батарейный блок в прохладном месте.

Во время зарядки батарейного блока лампочка CHG не будет загораться в следующих случаях

- Батарейный блок установлен не правильно.
- Что-то не в порядке с батарейным блоком.

Если питание может отключиться несмотря на то, батарейный блок достаточно заряжен для работы. Зарядите батарейный блок полностью, так чтобы индикация времени оставшегося заряда батарейного блока была правильной.

Step 1 Preparing the power supply

Charging time/Время зарядки

Battery pack/ Батарейный блок	Full charge / Полная зарядка
NP-F330 (supplied)/(прилагается)	150
NP-F530/F550	210
NP-F730/F750	300
NP-F930/F950	390
NP-F960	420

Approximate number of minutes to charge an empty battery pack

Пункт 1 Подготовка источника питания

Приблизительное время в минутах для зарядки полностью разряженного батарейного блока

Recording time/Время записи

CCD-TRV49E/TRV58E/TRV59E/TRV78E

Battery pack/ Батарейный блок	Recording with the viewfinder/ Запись с помощью видискателя		Recording with the LCD screen/ Запись с помощью экрана ЖКД	
	Continuous* Непрерывная*	Typical** Типичная**	Continuous* Непрерывная*	Typical** Типичная**
	NP-F330 (supplied)/(прилагается)	140	75	120
NP-F530	245	135	205	110
NP-F550	280	155	240	130
NP-F730	500	275	410	225
NP-F750	580	320	490	270
NP-F930	780	430	650	355
NP-F950	900	495	750	410
NP-F960	1035	570	880	490

CCD-TRV98E

Battery pack/ Батарейный блок	Recording with the viewfinder/ Запись с помощью видискателя		Recording with the LCD screen/ Запись с помощью экрана ЖКД	
	Continuous* Непрерывная*	Typical** Типичная**	Continuous* Непрерывная*	Typical** Типичная**
	NP-F330 (supplied)/(прилагается)	140	75	95
NP-F530	245	135	155	85
NP-F550	280	155	190	105
NP-F730	500	275	315	175
NP-F750	580	320	385	210
NP-F930	780	430	495	270
NP-F950	900	495	590	325
NP-F960	1035	570	700	385

Getting started

Подготовка к эксплуатации

17 18

Step 1 Preparing the power supply

Approximate number of minutes when you use a fully charged battery pack

* Approximate continuous recording time at 25°C (77°F). The battery life will be shorter if you use your camcorder in a cold environment.

** Approximate number of minutes when recording while you repeat recording start/stop, zooming and turning the power on/off. The actual battery life may be shorter.

Пункт 1 Подготовка источника питания

Приблизительное время в минутах при использовании полностью заряженного батарейного блока

* Приблизительное время непрерывной записи при температуре 25°C (77°F). При использовании видеокамеры в холодных условиях срок службы батарейного блока будет короче.

** Приблизительное время в минутах при записи с неоднократным пуском/остановкой записи, наведением видеокамеры и включением/выключением питания. Фактический срок службы заряда батарейного блока может быть короче.

Playing time/Время воспроизведения

CCD-TRV49E/TRV58E/TRV59E/TRV78E

Battery pack/ Батарейный блок	Playing time on LCD screen/ Время воспроизведения на экране ЖКД	Playing time with LCD closed/ Время воспроизведения при закрытом ЖКД
NP-F330 (supplied)/(прилагается)	120	145
NP-F530	205	260
NP-F550	240	295
NP-F730	410	525
NP-F750	490	610
NP-F930	650	825
NP-F950	750	930
NP-F960	880	1090

CCD-TRV98E

Battery pack/ Батарейный блок	Playing time on LCD screen/ Время воспроизведения на экране ЖКД	Playing time with LCD closed/ Время воспроизведения при закрытом ЖКД
NP-F330 (supplied)/(прилагается)	95	145
NP-F530	155	260
NP-F550	190	295
NP-F730	315	525
NP-F750	385	610
NP-F930	495	825
NP-F950	590	930
NP-F960	700	1090

Step 1 Preparing the power supply

Approximate number of minutes when you use a fully charged battery pack

The battery life will be shorter if you use your camcorder in a cold environment.

What is "InfoLITHIUM"?

The "InfoLITHIUM" is a lithium ion battery pack which can exchange data such as battery consumption with compatible electronic equipment. This unit is compatible with the "InfoLITHIUM" battery pack (L series). Your camcorder operates only with the "InfoLITHIUM" battery. "InfoLITHIUM" L series battery packs have the  mark. "InfoLITHIUM" is a trademark of Sony Corporation.

Пункт 1 Подготовка источника питания

Приблизительное время в минутах при использовании полностью заряженного батарейного блока

При использовании видеокамеры в холодных условиях срок службы батарейного блока будет короче.

Что такое "InfoLITHIUM"?

"InfoLITHIUM" представляет собой литиево-ионный батарейный блок, который может обмениваться данными, такими как потребление заряда батарейного блока, с совместимой электронной аппаратурой. Это устройство совместимо с батарейным блоком "InfoLITHIUM" (серии L). Ваша видеокамера работает только с батарейным блоком "InfoLITHIUM". На батарейных блоках серии "InfoLITHIUM" L имеется знак . "InfoLITHIUM" является торговой маркой корпорации Sony Corporation.

Getting started

Подготовка к эксплуатации

Step 1 Preparing the power supply

Connecting to the mains

When you use your camcorder for a long time, we recommend that you power it from the mains using the AC power adaptor.

- (1) Open the DC IN jack cover, and connect the AC power adaptor to the DC IN jack on your camcorder with the plug's ▲ mark facing up.
- (2) Connect the mains lead to the AC power adaptor.
- (3) Connect the mains lead to the mains.

Пункт 1 Подготовка источника питания

Подсоединение к сетевой розетке

Если Вы собираетесь использовать видеокамеру длительное время, рекомендуется использовать питание от электрической сети с помощью сетевого адаптера переменного тока.

- (1) Откройте крышку гнезда DC IN и подсоедините сетевой адаптер переменного тока к гнезду DC IN на Вашей видеокамере, так чтобы знак ▲ на штекере был обращен вверх.
- (2) Подсоедините провод электропитания к сетевому адаптеру переменного тока.
- (3) Подсоедините провод электропитания к сетевой розетке.

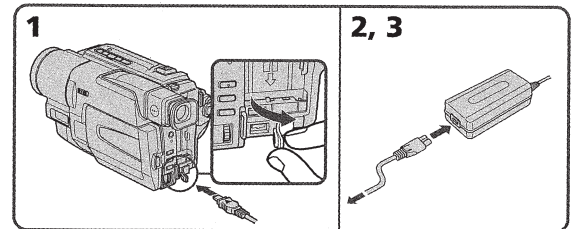

19 20

Step 1 Preparing the power supply

PRECAUTION

The set is not disconnected from the AC power source (mains) as long as it is connected to the mains, even if the set itself has been turned off.

Notes

- The AC power adaptor can supply power even if the battery pack is attached to your camcorder.
- The DC IN jack has "source priority". This means that the battery pack cannot supply any power if the mains lead is connected to the DC IN jack, even when the mains lead is not plugged into the mains.
- Place the AC power adaptor near mains.
- While using the AC power adaptor, if any trouble occurs with this unit, disconnect the plug from the mains as soon as possible to cut off the power.

Using a car battery

Use Sony DC Adaptor/Charger (optional).

Пункт 1 Подготовка источника питания

МЕРА ПРЕДОСТОРОЖНОСТИ

Аппарат не отключается от источника питания переменного тока (электрической сети) до тех пор, пока он остается подсоединенным к электрической сети, даже если сам аппарат и выключен.

Примечания

- Питание от сетевого адаптера переменного тока может подаваться даже в случае, если батарейный блок прикреплен к Вашей видеокамере.
- Гнездо DC IN имеет "приоритет источника". Это значит, что питание от батарейного блока не может подаваться, если провод электропитания подсоединен к гнезду DC IN, даже если провод электропитания и не подсоединен к сетевой розетке.
- Разместите сетевой адаптер переменного тока возле электросети. Во время использования сетевого адаптера переменного тока, если с данным аппаратом возникнет какая-либо проблема, отсоедините штекер от электросети как можно быстрее для отключения питания.

Использование автомобильного аккумулятора

Используйте адаптер/зарядное устройство постоянного тока Sony (не прилагается).

Getting started

Подготовка к эксплуатации

Step 2 Setting the date and time

Set the date and time settings when you use your camcorder for the first time.

If you do not use your camcorder for about 4 months, the date and time settings may be released (bars may appear) because the built-in rechargeable lithium cell in your camcorder will have been discharged.

First, set the year, then the month, the day, the hour and then the minute.

- While your camcorder is in CAMERA mode, press MENU to display the menu.
- Turn the SEL/PUSH EXEC dial to select , then press the dial.
- Turn the SEL/PUSH EXEC dial to select CLOCK SET, then press the dial.
- Turn the SEL/PUSH EXEC dial to adjust the desired year, then press the dial.
- Set the month, day and hour by turning the SEL/PUSH EXEC dial and pressing the dial.
- Set the minute by turning the SEL/PUSH EXEC dial and pressing the dial by the time signal. The clock starts to move.
- Press MENU to make the menu disappear. The time indicator appears.

Пункт 2 Установка даты и времени

Если Вы используете Вашу видеокамеру впервые, выполните установки даты и времени.

Если Вы не собираетесь использовать Вашу видеокамеру около 4 месяцев, установки даты и времени могут быть стерты (могут появиться черточки), потому что встроенный перезаряжаемый литиевый элемент в Вашей видеокамере разрядится. Сначала установите год, затем месяц, день, час, а затем минуту.

- В режиме видеокамеры CAMERA, нажмите кнопку MENU для отображения меню.
- Поверните диск SEL/PUSH EXEC для выбора индикации , а затем нажмите диск.
- Поверните диск SEL/PUSH EXEC для выбора команды CLOCK SET, а затем нажмите диск.
- Поверните диск SEL/PUSH EXEC для выбора нужного года, а затем нажмите диск.
- Установите месяц, день и час путем вращения диска SEL/PUSH EXEC и нажатия диска.
- Установите минуту путем вращения диска SEL/PUSH EXEC и нажатия диска в момент передачи сигнала точного времени. Часы начнут функционировать.
- Нажмите кнопку MENU для того, чтобы закрыть меню. Появится индикатор времени.

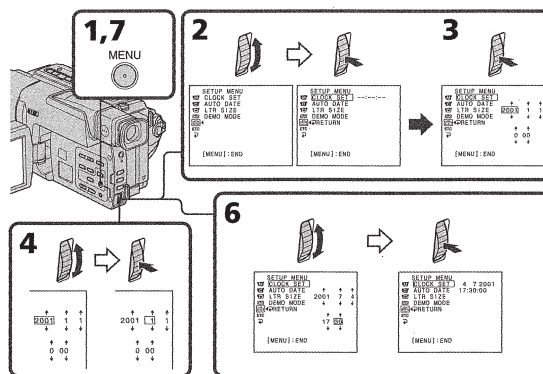

21

22

Step 2 Setting the date and time

To check the preset date and time

Press DATE to display the date indicator. Press TIME to display the time indicator. Press DATE (or TIME) and then press TIME (or DATE) to simultaneously display the date and time indicator. Press DATE and/or TIME again. The date and/or time indicator disappears.

The year changes as follows:

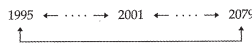

Auto date function

When you use your camcorder for the first time, turn it on and reset the date and time to your local time before you start recording (p. 22). The date is automatically recorded for 10 seconds after you start recording (Auto date function). This function works only once a day.

Note on the time indicator

The internal clock of your camcorder operates on a 24-hour cycle.

Note on the auto date function

You can change the AUTO DATE setting by selecting ON or OFF in the menu settings. The auto date function automatically displays the date once a day.

- However, the date may automatically appear more than once a day if:
 - you reset the date and time.
 - you eject and insert the tape again.
 - you stop recording within 10 seconds.
 - you set AUTO DATE to OFF once and set it back to ON in the menu settings.

Пункт 2 Установка даты и времени

Для проверки предварительно установленных даты и времени

Нажмите кнопку DATE для отображения индикатора даты. Нажмите кнопку TIME для отображения индикатора времени. Нажмите кнопку DATE (или TIME), а затем нажмите кнопку TIME (или DATE) для одновременного отображения индикатора даты и времени. Нажмите еще раз кнопку DATE и/или TIME. Индикатор даты и/или времени исчезнет.

Год изменяется следующим образом:

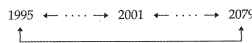

Функция автоматической даты

Если Вы используете видеокамеру первый раз, включите ее и переустановите дату и время в соответствии со своим часовым поясом, прежде чем начать запись (стр. 22). Дата будет автоматически записываться в течение 10 секунд после начала записи (функция автоматической даты). Эта функция работает только один раз в день.

Примечание по индикатору времени

Встроенные часы Вашей видеокамеры работают в 24-часовом режиме.

Примечание по функции автоматической даты

Вы можете изменять установку AUTO DATE путем выбора положений ON или OFF в установках меню. Функция автоматической даты автоматически отображает дату один раз в день.

- Однако, дата может автоматически появляться больше одного раза при:
 - переустановке даты и времени.
 - вытапливании и установке ленты обратно на место.
 - остановке записи в пределах 10 секунд.
 - установке команды AUTO DATE в положение OFF и возвращении в положение ON в установках меню.

Getting started

Подготовка к эксплуатации

Step 3 Inserting a cassette

When you want to record in the Hi8 system, use Hi8 video cassettes **Hi8**.

- Prepare the power supply (p. 14).
- Open the lid of the cassette compartment, and press EJECT. The cassette compartment opens automatically.
- Insert a cassette with its window facing out and the write-protect tab on the cassette up.
- Close the cassette compartment by pressing the  mark on the cassette compartment. The cassette compartment automatically goes down.
- Close the lid of the cassette compartment.

Пункт 3 Установка кассеты

Если Вы хотите выполнять запись в системе Hi8, используйте видеокассету Hi8 **Hi8**.

- Подготовьте источник питания (стр. 14).
- Откройте крышку кассетного отсека и нажмите кнопку EJECT. Кассетный отсек откроется автоматически.
- Вставьте кассету так, чтобы окошко было обращено наружу, а лепесток защиты от записи на кассете – вверх.
- Закройте кассетный отсек, нажав метку  на кассетном отсеке. Кассетный отсек автоматически опустится вниз.
- Закройте крышку кассетного отсека.

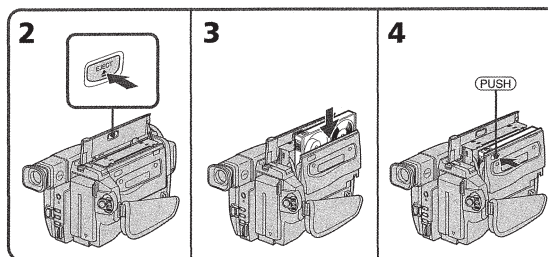

To eject a cassette

Follow the procedure above, and eject the cassette in step 3.

Для извлечения кассеты

Следуйте описанной выше процедуре и извлеките кассету в пункте 3.

23

24

Step 3 Inserting a cassette

Notes

- Do not press the cassette compartment down. Doing so may cause a malfunction.
- The cassette compartment may not be closed when you press any part of the cassette compartment other than the  mark.
- Do not pick up your camcorder by holding the lid of the cassette compartment.

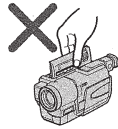

To prevent accidental erasure

Slide the write-protect tab on the cassette to expose the red mark.

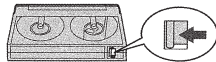

Пункт 3 Установка кассеты

Примечания

- Не нажимайте вниз кассетный отсек. Это может привести к неисправности.
- Кассетный отсек может не закрыться, если Вы нажмете на какое-либо другое место на кассетном отсеке, а не на отметку .
- Не поднимайте Вашу видеокамеру, удерживая ее за крышку кассетного отсека.

Для предотвращения случайного стирания

Передвиньте лепесток защиты записи на кассете, так чтобы появилась красная метка.

Getting started Подготовка к эксплуатации

— Recording — Basics —

Recording a picture

Your camcorder automatically focuses for you.

- (1) Remove the lens cap by pressing both knobs on its sides and attach the lens cap to the grip strap.
- (2) Install the power source and insert a cassette. See "Step 1" to "Step 3" for more information (p. 14 to 25).
- (3) Set the POWER switch to CAMERA while pressing the small green button. Your camcorder is set to the standby mode.
- (4) Open the LCD panel while pressing OPEN. The viewfinder automatically turns off.
- (5) Press START/STOP. Your camcorder starts recording. The REC indicator appears. The camera recording lamp located on the front of your camcorder lights up. To stop recording, press START/STOP again. The recording lamp lights up in the viewfinder when you record with the viewfinder.

— Запись — Основные положения —

Запись изображения

Ваша видеокамера автоматически выполнит фокусировку за Вас.

- (1) Снимите крышку объектива, нажав обе кнопки на ее краях, и прикрепите крышку объектива к ремню для захвата.
- (2) Установите источник питания и вставьте кассету. Подробные сведения приведены в "Пункте 1" до "Пункте 3" (стр. 14 – 25).
- (3) Нажав маленькую зеленую кнопку, установите переключатель POWER в положение CAMERA. Ваша видеокамера переключится в режим ожидания.
- (4) Нажав кнопку OPEN, откройте панель ЖКД. Видоискатель выключится автоматически.
- (5) Нажмите кнопку START/STOP. Ваша видеокамера начнет запись. Появится индикатор REC. Высветится также лампочка записи, расположенная на передней панели видеокамеры. Для остановки записи нажмите кнопку START/STOP еще раз. При записи с помощью видоискателя, внутри него высветится лампочка записи.

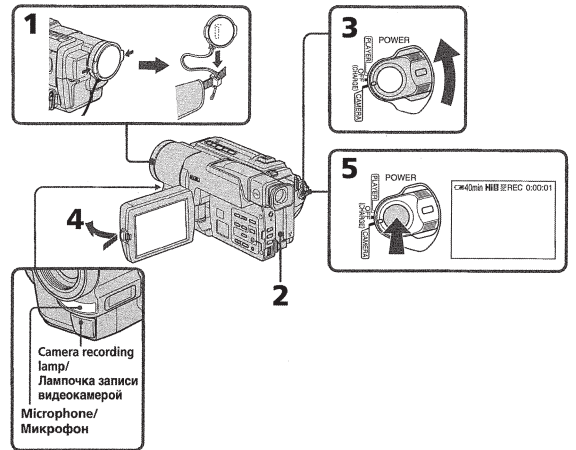

25 26

Recording a picture

Note

Fasten the grip strap firmly. Do not touch the built-in microphone during recording.

To enable smooth transition

You can make the transition between the last scene you recorded and the next scene smooth as long as you do not eject the cassette even if you turn off your camcorder. When you change the battery pack, set the POWER switch to OFF (CHARGE).

If you leave your camcorder in the standby mode for 5 minutes while the cassette is inserted

Your camcorder automatically turns off. This is to save battery power and to prevent battery and tape wear. To resume the standby mode, set the POWER switch to OFF (CHARGE) once, then turn it to CAMERA again.

To set the counter to 0:00:00

Press COUNTER RESET (p. 113).

After recording

- (1) Set the POWER switch to OFF (CHARGE).
- (2) Close the LCD panel.
- (3) Eject the cassette.
- (4) Attach the lens cap

After using your camcorder

Remove the battery pack from your camcorder to avoid turning on the built-in light accidentally.

Запись изображения

Примечания

Плотно пристегните ремень для захвата видеокамеры. Не прикасайтесь к встроенному микрофону во время записи.

Для обеспечения плавного перехода

Вы можете выполнять плавный переход между последним записанным эпизодом и следующим эпизодом до тех пор, пока не извлечете кассету, даже при выключении Вашей видеокамеры. При замене батарейного блока установите переключатель POWER в положение OFF (CHARGE).

Если Вы оставите Вашу видеокамеру в режиме готовности на 5 минут при вставленной кассете

Ваша видеокамера выключится автоматически. Это предотвращает расход заряда батарейного блока и износ ленты. Для возобновления режима ожидания установите сначала переключатель POWER в положение OFF (CHARGE), а затем снова верните его в положение CAMERA.

Для установки счетчика в положение 0:00:00

Нажмите кнопку COUNTER RESET (стр. 113).

После записи

- (1) Установите переключатель POWER в положение OFF (CHARGE).
- (2) Закройте панель ЖКД.
- (3) Извлеките кассету.
- (4) Присоедините колпачок объектива

После использования видеокамеры

Выньте батарейный блок из Вашей видеокамеры во избежание случайного включения встроенной подсветки.

Recording — Basics Запись — Основные положения

Recording a picture

Adjusting the LCD screen

The LCD panel moves about 90 degrees to the viewfinder side and about 180 degrees to the lens side.

If you turn the LCD panel over so that it faces the other way, the  indicator appears on the screen (Mirror mode).

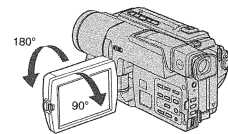

When closing the LCD panel, set it vertically until it clicks, and swing it into the camcorder body.

Note

When using the LCD screen except in the mirror mode, the viewfinder automatically turns off.

When you use the LCD screen outdoors in direct sunlight

The LCD screen may be difficult to see. If this happens, we recommend that you use the viewfinder.

Picture in the mirror mode

The picture on the LCD is a mirror-image. However, the picture will be normal when recorded.

During recording in the mirror mode

DATE and TIME on your camcorder do not work.

Запись изображения

Регулировка экрана ЖКД

Панель ЖКД может передвигаться примерно на 90 градусов в сторону видоискателя и примерно на 180 градусов в сторону объектива.

Если Вы повернете панель ЖКД так, что будет направлена в другую сторону, на экране появится индикатор  (Зеркальный режим).

При закрытии панели ЖКД установите ее вертикально, пока не раздастся щелчок, а затем присоедините ее к корпусу видеокамеры.

Примечание

При использовании экрана ЖКД видоискатель автоматически выключается, кроме зеркального режима.

Если Вы используете экран ЖКД вне помещения под прямым солнечным светом

Возможно будет трудно разглядеть экран ЖКД. В этом случае рекомендуется использовать видоискатель.

Изображение в зеркальном режиме

Изображение на экране ЖКД будет отображаться зеркально. Однако запись изображения будет нормальной.

Во время записи в зеркальном режиме функции DATE и TIME на Вашей видеокамере не работают.

27 28

Recording a picture

Indicators in the mirror mode

- The STBY indicator appears as **II** and REC as **●**. Some of the other indicators appear mirror-reversed and others are not displayed.
- The date appears mirror-reversed when the auto date function is working. However, the date will be normal when recorded.

Adjusting the brightness of the LCD screen

Adjust the brightness of the LCD screen with LCD BRIGHT in **☐** in the menu settings.

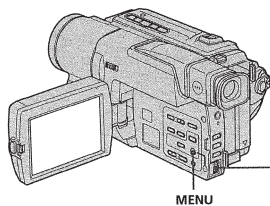

MENU

LCD screen backlight

You can adjust the brightness of the backlight. Select LCD B.L. in the menu settings (p. 70).

Even if you adjust the LCD screen backlight The recorded picture will not be affected.

Запись изображения

Индикаторы в зеркальном режиме

- Индикатор STBY появится в виде **II**, а индикатор REC в виде **●**. Некоторые другие индикаторы появятся в зеркальном отображенном виде, а некоторые из них не будут отображаться совсем.
- В случае, если работает функция автоматической даты, то дата будет отображаться зеркально, однако на записи дата будет в нормальном виде.

Регулировка яркости экрана ЖКД

Отрегулируйте яркость экрана ЖКД с помощью команды LCD BRIGHT в **☐** в установках меню.

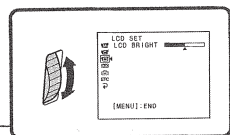

Задняя подсветка экрана ЖКД

Вы можете отрегулировать яркость задней подсветки. Выберите пункт LCD B.L. в установках меню (стр. 75).

Даже если Вы регулируете заднюю подсветку экрана ЖКД На записанное изображение это не повлияет.

Recording - Basics Запись - Основные положения

29 30

Recording a picture

When you shoot close to a subject

If you cannot get a sharp focus, move the power zoom lever to the "W" side until the focus is sharp. You can shoot a subject that is at least about 80 cm (about 2 feet 5/8 inch) away from the lens surface in the telephoto position, or about 1 cm (about 1/2 inch) away in the wide-angle position.

Notes on digital zoom

- Digital zoom starts to function when zoom exceeds 20x.
- The picture quality deteriorates as you go toward the "T" side.

To record pictures with the viewfinder - adjusting the viewfinder

If you record pictures with the LCD panel closed, check the picture with the viewfinder. Adjust the viewfinder lens to your eyesight so that the indicators in the viewfinder come into sharp focus.

Lift up the viewfinder and move the viewfinder lens adjustment lever.

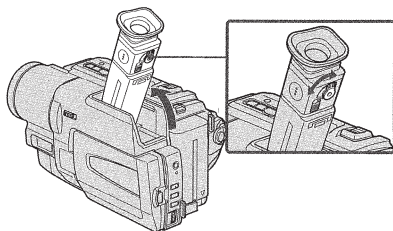

Запись изображения

При съемке объекта с близкого положения

Если Вы не можете получить четкой фокусировки, передвиньте рычаг приводной вариообъектива сторону "W" до получения четкой фокусировки. Вы можете выполнять съемку объекта в положении телефото, который отстоит от крайней мере на расстоянии 80 см от поверхности объектива или же около 1 см в положении широкоугольного вида.

Примечания к наезду видеокамеры цифровым методом

- Цифровой вариообъектив начинает срабатывать в случае, если наезд видеокамеры превышает 20x.
- Качество изображения ухудшается по мере приближения к стороне "T".

Для записи изображений с помощью видоискателя - регулировка видоискателя

Если Вы будете записывать изображения при закрытой панели ЖКД, проверяйте изображение с помощью видоискателя. Отрегулируйте объектив видоискателя в соответствии со своим зрением, так чтобы индикаторы в видоискателе были четко сфокусированы.

Поднимите видоискатель и подвигайте рычаг регулировки объектива видоискателя.

Recording - Basics Запись - Основные положения

31 32

1-6

Recording a picture

Using the zoom feature

Move the power zoom lever a little for a slower zoom. Move it further for a faster zoom. Using the zoom function sparingly results in better-looking recordings. "T" side: for telephoto (subject appears closer) "W" side: for wide-angle (subject appears farther away)

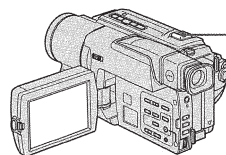

Zoom greater than 20x is performed digitally. To activate digital zoom, select the digital zoom power in D ZOOM in the menu settings (p. 69). The picture quality deteriorates as the picture is processed digitally.

Запись изображения

Использование функции наезда видеокамеры

Передвиньте рычаг приводной вариообъектива слегка для относительно медленного наезда видеокамеры. Передвиньте его сильнее для ускоренного наезда видеокамеры. Использование функции наезда видеокамеры в небольшом количестве обеспечивает наилучшие результаты. Сторона "T" : для телефото (объект приближается) Сторона "W" : для широкоугольного вида (объект удаляется)

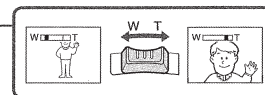

Наезд видеокамеры более 20x выполняется цифровым методом. Для приведения в действие цифрового вариообъектива выберите в установках меню приводной цифровой вариообъектив D ZOOM (стр. 74). Качество изображения будет немного худшим, поскольку обработка изображения ведется цифровым способом.

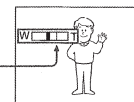

The right side of the bar shows the digital zooming zone. The digital zooming zone appears when you select the digital zoom power in D ZOOM in the menu settings. / Правая сторона полосы на экране показывает зону цифровой трансфокации. Если в установках меню Вы выберите цифровой приводной объектив D ZOOM, то появится зона цифровой трансфокации.

Recording a picture

Indicators displayed in the recording mode

The indicators are not recorded on tape.

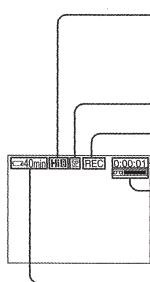

Hi8 format indicator

This appears while playing back or recording in Hi8 format. This appears after you insert a cassette for a while. / Индикатор формата Hi8

Этот индикатор появляется во время воспроизведения или записи в формате Hi8. Этот индикатор появляется через некоторое время после установки кассеты. /

Recording mode indicator/Индикатор режима записи

STBY/REC indicator/Индикатор STBY/REC

Tape counter indicator/Индикатор счетчика ленты

Remaining tape indicator

This appears after you insert a cassette and record or play back for a while. / Индикатор оставшейся ленты

Remaining battery time indicator/

Индикатор времени оставшегося заряда батарейного блока

Note on the remaining battery time indicator

The remaining battery time indicator roughly indicates the recording time. The indicator may not be correct, depending on the conditions in which you are recording when you close the LCD panel and open it again, it takes about 1 minute for the correct remaining battery time in minutes to be displayed.

Примечание относительно времени оставшегося заряда батарейного блока

Индикатор времени оставшегося заряда батарейного блока в окошке дисплея в общем означает время записи. Индикатор может быть неточным, в зависимости от условий, в которых Вы выполняете запись. Если закроете панель ЖКД и откроете ее снова, понадобится около 1 минуты для того, чтобы правильное время оставшегося заряда батарейного блока отобразилось на дисплее.

31 32

Recording a picture

Shooting backlit subjects – BACK LIGHT

When you shoot a subject with the light source behind the subject or a subject with a light background, use the backlight function.

Press BACK LIGHT in CAMERA mode. The  indicator appears on the screen. To cancel, press BACK LIGHT again.

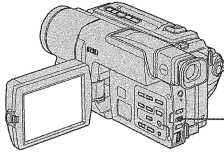

Запись изображения

Съемка объектов с задней подсветкой – BACK LIGHT

Если Вы выполняете съемку объекта с источником света позади него или же объекта со светлым фоном, используйте функцию задней подсветки.

Нажмите кнопку BACK LIGHT в режиме CAMERA. На экране появится индикатор . Для отмены, нажмите кнопку BACK LIGHT.

If you press EXPOSURE when shooting backlit subjects
The backlight function will be canceled.

Если вы нажмете кнопку EXPOSURE при выполнении съемки объектов с задней подсветкой
Функция задней подсветки будет отменена.

Recording – Basics
Запись – Основные положения

Recording a picture

Shooting in the dark – NightShot

The NightShot function enables you to shoot a subject in a dark place. For example, you can satisfactorily record the environment of nocturnal animals for observation when you use this function.

While your camcorder is in CAMERA mode, slide NIGHTSHOT to ON.  and "NIGHTSHOT" indicators flash on the screen. To cancel the NightShot function, slide NIGHTSHOT to OFF.

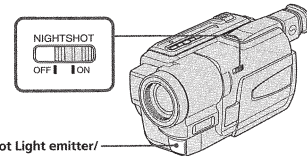

NightShot Light emitter/
Излучатель подсветки
для ночной съемки

Using the NightShot Light

The picture will be clearer with the NightShot Light on. To enable the NightShot Light, set N.S.LIGHT to ON in the menu settings (p. 69).

Запись изображения

Съемка в темноте – Ночная съемка

Функция ночной съемки позволяет Вам выполнять съемку объектов в темных местах. Например, Вы сможете с успехом выполнять съемку ночных животных для наблюдения при использовании данной функции.

В то время, когда Ваша видеокамера находится в режиме CAMERA, передвиньте переключатель NIGHTSHOT в положение ON. Индикаторы  и "NIGHTSHOT" начнут мигать на экране. Для отмены функции ночной съемки передвиньте переключатель NIGHTSHOT в положение OFF.

Использование подсветки для ночной съемки

Изображение станет ярче, если включить функцию ночной подсветки. Для включения функции ночной подсветки установите переключатель N.S.LIGHT в положение ON в установках меню (стр. 74).

33 34

Recording a picture

Notes

- Do not use the NightShot function in bright places (ex. outdoors in the daytime). This may cause your camcorder to malfunction.
- When you keep NIGHTSHOT setting to ON in normal recording, the picture may be recorded in incorrect or unnatural colours.
- If focusing is difficult with the autofocus mode when using the NightShot function, focus manually.

While using the NightShot function, you can not use the following functions:

- Exposure
- PROGRAM AE

NightShot Light

NightShot Light rays are infrared and so are invisible. The maximum shooting distance using the NightShot Light is about 3 m (10 feet).

Запись изображения

Примечания

- Не используйте функцию ночной съемки в ярких местах (например, на улице в дневное время). Это может привести к неисправности Вашей видеокамеры.
- При удержании установки NIGHTSHOT в положении ON при нормальной записи изображение может быть записано в неправильных или неестественных цветах.
- Если фокусировка затруднена в автоматическом режиме при использовании функции ночной съемки, выполните фокусировку вручную.

При использовании функции ночной съемки Вы не можете использовать следующие функции:

- Экспозиция
- PROGRAM AE

Подсветка для ночной съемки

Лучи подсветки для ночной съемки являются инфракрасными и поэтому невидимыми. Максимальное расстояние для съемки при использовании подсветки для ночной съемки равно примерно 3 м.

Recording – Basics
Запись – Основные положения

Recording a picture

Superimposing the date and time on pictures

You can record the date and/or time displayed on the screen superimposed on the picture. Carry out the following operations in CAMERA mode.

Press DATE to record the date.
Press TIME to record the time.
Press DATE (or TIME), then press TIME (or DATE) to record the date and time.

Press DATE and/or TIME again. The date and/or time indicator disappears.

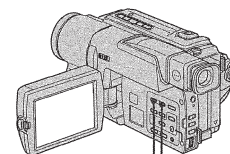

When you purchase your camcorder, the clock setting is set to off. Set the date and time to your local time before using (p. 22).

Note

The date and time indicators recorded manually cannot be deleted.

If you do not record the date and time in the picture

Record the date and time in the black screen as the background for about 10 seconds, then erase the date and time indicators before starting actual recording.

Запись изображения

Наложение даты и времени на изображения

Вы можете записывать дату и/или время, отображаемые на экране, которые будут наложены на изображение. Выполните следующие операции в режиме CAMERA.

Нажмите кнопку DATE для записи даты. Нажмите кнопку TIME для записи даты. Нажмите кнопку DATE (или TIME), затем нажмите кнопку TIME (или DATE) для записи даты и времени.

Нажмите кнопку DATE и/или TIME еще раз. Индикатор даты и/или времени исчезнет.

Когда Вы покупаете Вашу видеокамеру, установка часов выключена. Установите дату и время в соответствии с Вашим местным временем перед использованием (стр.22).

Примечание

Индикаторы даты и времени, записанные вручную, не могут быть удалены.

Если Вы не записываете дату и время на изображении

Запишите дату и время на фоне черного экрана в течение 10 секунд, затем сотрите индикаторы даты и времени перед тем, как начать действительную запись.

35 36

Checking the recording – END SEARCH

You can use this button to record a picture from the last recorded scene successively.

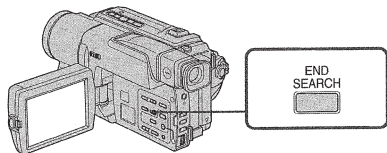

You can go to the end of the recorded section after you record.

Press END SEARCH in CAMERA mode. The last 5 seconds of the recorded section are played back and the playback stops. You can monitor the sound from the speaker or an earphone.

Note

If you start recording after using the end search function, occasionally, the transition between the last scene you recorded and the next scene may not be smooth.

Once you eject the cassette after you have recorded on the tape the end search function does not work.

Проверка записи – END SEARCH

Вы можете использовать эту кнопку для последовательной записи за последним записанным эпизодом.

Вы можете дойти до конца записанной части ленты после выполнения записи.

Нажмите кнопку END SEARCH в режиме CAMERA. Будут воспроизведены последние 5 секунд записанной части, и воспроизведение остановится. Вы можете контролировать звук через акустическую систему или наушники.

Примечание

Если Вы случайно начнете запись после использования функции поиска конца записи, переход между последней записанной сценой и следующей записываемой сценой может не быть плавным.

Если Вы вынули кассету после записи на ленту функция поиска конца записи работать не будет.

Recording - Basics Запись - Основные положения

— Playback - Basics —

Playing back a tape

You can monitor the playback picture on the screen. If you close the LCD panel, you can monitor the playback picture in the viewfinder. You can control playback using the Remote Commander supplied with your camcorder. (CCD-TRV49E/TRV59E/TRV78E/TRV98E)

- (1) Install the power source and insert the recorded tape.
- (2) Set the POWER switch to PLAYER while pressing the small green button.
- (3) Open the LCD panel while pressing OPEN.
- (4) Press ◀ to rewind the tape.
- (5) Press ▶ to start playback.
- (6) To adjust the volume, press either of the two buttons on VOLUME. The speaker on your camcorder is silent when the LCD panel is closed.

— Воспроизведение - Основные положения —

Воспроизведение ленты

Вы можете контролировать воспроизводимое изображение на экране. Если Вы закроете панель ЖКД, Вы сможете контролировать воспроизводимое изображение в видоискателе. Вы можете контролировать воспроизведение с помощью пульта дистанционного управления, прилагаемого к Вашей видеокамере. (модели CCD-TRV49E/TRV59E/TRV78E/TRV98E)

- (1) Установите источник питания и вставьте записанную ленту.
- (2) Установите переключатель POWER в положение PLAYER, нажав маленькую зеленую кнопку.
- (3) Нажав кнопку OPEN, откройте панель ЖКД.
- (4) Нажмите кнопку ◀ для ускоренной перемотки ленты назад.
- (5) Нажмите кнопку ▶ для включения воспроизведения.
- (6) Для регулировки громкости нажимайте одну из двух кнопок VOLUME. Если панель ЖКД на Вашей видеокамере закрыта, динамик не будет работать.

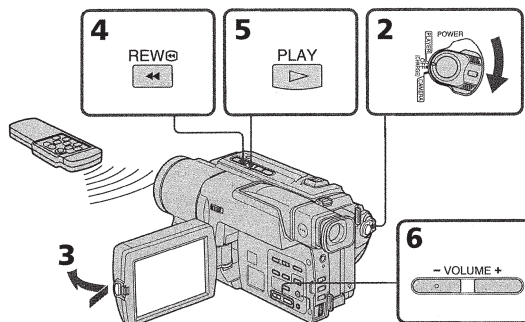

To stop playback Press ■.

Для остановки воспроизведения Нажмите кнопку ■.

37 38

Playing back a tape

When monitoring on the LCD screen
You can turn the LCD panel over and move it back to the camcorder body with the LCD screen facing out [a]. You can adjust the angle of the LCD panel by lifting the LCD panel up by 23 degrees [b].

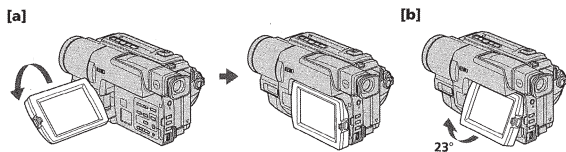

To control the display of the screen indicators

Press DISPLAY on your camcorder or the Remote Commander (CCD-TRV49E/TRV59E/TRV78E/TRV98E) supplied with your camcorder.

The indicators appear on the LCD screen. To make the indicators disappear, press DISPLAY again.

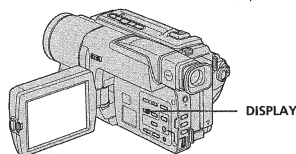

Воспроизведение ленты

Во время контроля на экране ЖКД
Вы можете повернуть панель управления и придвинуть ее обратно на место к корпусу видеокамеры, так что экран ЖКД будет обращен наружу [a]. Вы можете отрегулировать угол панели ЖКД, подняв панель ЖКД вверх на 23 градуса [b].

Для контроля экранных индикаторов

Нажмите кнопку DISPLAY на Вашей видеокамере или на пульте дистанционного управления (модели CCD-TRV-49E/TRV59E/TRV78E/TRV98E), который прилагается к Вашей видеокамере. На экране ЖКД появятся индикаторы. Для того, чтобы индикаторы исчезли, нажмите еще раз кнопку DISPLAY.

Playback - Basics Воспроизведение - Основные положения

Playing back a tape

Various playback modes

To operate video control buttons, set the POWER switch to PLAYER.

To view a still picture (playback pause)

Press II during playback. To resume playback, press II or ▶.

To advance the tape

Press ▶ in the stop mode. To resume normal playback, press ▶.

To rewind the tape

Press ◀ in the stop mode. To resume normal playback, press ▶.

To locate a scene monitoring the picture (picture search)

Keep pressing ◀ or ▶ during playback. To resume normal playback, release the button.

To monitor the high-speed picture while advancing or rewinding the tape (skip scan)

Keep pressing ◀ while rewinding or ▶ while advancing the tape. To resume rewinding or advancing, release the button.

To view the picture at slow speed (slow playback)

— CCD-TRV49E/TRV59E/TRV78E/TRV98E only
Press ▶ on the Remote Commander during playback. To resume normal playback, press ▶.

To search the last scene recorded (END SEARCH)

Press END SEARCH in the stop mode. The last 5 seconds of the recorded section are played back and the playback stops.

Воспроизведение ленты

Переменные режимы воспроизведения

Для использования кнопок управления видео установите переключатель POWER в положение PLAYER.

Для просмотра неподвижного изображения (пауза воспроизведения)

Нажмите во время воспроизведения кнопку II. Для возобновления обычного воспроизведения нажмите кнопку II или кнопку ▶.

Для ускоренной перемотки ленты вперед

Нажмите в режиме остановки кнопку ▶. Для возобновления обычного воспроизведения нажмите кнопку ▶.

Для ускоренной перемотки ленты назад

Нажмите в режиме остановки кнопку ◀. Для возобновления обычного воспроизведения нажмите кнопку ▶.

Для отыскания эпизода во время контроля изображения (поиск изображения)

Держите нажатой кнопку ◀ или ▶ во время воспроизведения. Для восстановления обычного воспроизведения отпустите кнопку.

Для контроля изображения на высокой скорости во время ускоренной перемотки ленты вперед или назад (поиск методом прогона)

Держите нажатой кнопку ◀ во время ускоренной перемотки ленты назад или кнопку ▶ во время ускоренной перемотки ленты вперед. Для возобновления обычной перемотки ленты вперед или назад отпустите кнопку.

Для просмотра изображения на медленной скорости (замедленное воспроизведение)

— Только модели CCD-TRV49E/TRV59E/TRV78E/TRV98E

Нажмите во время воспроизведения кнопку ▶ на пульте дистанционного управления. Для возобновления обычного воспроизведения нажмите кнопку ▶.

Для поиска последнего записанного эпизода (END SEARCH)

Нажмите кнопку END SEARCH в режиме остановки. Будут воспроизведены последние 5 секунд записанного участка, и воспроизведение прекратится.

39 40

Playing back a tape

In the various playback modes
Sound is muted.

When the playback pause mode lasts for 5 minutes
Your camcorder automatically enters the stop mode. To resume playback, press ►.

If slow playback lasts for about 1 minute (CCD-TRV49E/TRV59E/TRV78E/TRV98E only)
Your camcorder automatically returns to normal speed.

When you play back a tape
Noise may appear during playback pause mode, slow playback or picture search.

When you play back a tape in reverse
Horizontal noise may appear at the centre or top and bottom of the screen.
This is not a malfunction.

Воспроизведение ленты

В переменных режимах воспроизведения
Звук будет приглушен.

Если режим паузы воспроизведения продлится 5 минут
Ваша видеокамера автоматически войдет в режим остановки. Для возобновления воспроизведения воспроизведения нажмите кнопку ►.

Если замедленное воспроизведение продлится около 1 минуты (Только модели CCD-TRV49E/TRV59E/TRV78E/TRV98E)
Ваша видеокамера автоматически переключится на нормальную скорость.

При воспроизведении записанной ленты
В режиме паузы воспроизведения, замедленного воспроизведения или поиска изображения могут появиться помехи.

При воспроизведении ленты в обратном направлении
Могут появиться горизонтальные помехи в центре или сверху и внизу экрана. Этой не является неисправностью.

Viewing the recording on TV

Connect your camcorder to your TV with the A/V connecting cable supplied with your camcorder to watch the playback picture on the TV screen. You can operate the playback control buttons in the same way as when you monitor playback pictures on the LCD screen. When monitoring the playback picture on the TV screen, we recommend that you power your camcorder from the mains using the AC power adaptor (p. 20). Refer to the operating instructions of your TV.

Open the jack cover. Connect your camcorder to the TV using the A/V connecting cable. Then, set the TV/VCR selector on the TV to VCR.

Просмотр записи на экране телевизора

Подсоедините Вашу видеокамеру к Вашему телевизору с помощью соединительного кабеля аудио/видео, который прилагается к Вашей видеокамере для просмотра воспроизводимого изображения на экране телевизора. Вы можете оперировать кнопками управления воспроизведением таким же способом, как при управлении воспроизводимым изображением на экране ЖКД. При управлении воспроизводимым изображением на экране телевизора рекомендуется подключить питание к Вашей видеокамере от сетевой розетки с помощью сетевого адаптера переменного тока (стр. 20). См. инструкцию по эксплуатации Вашего телевизора.

Откройте крышку гнезд. Подсоедините Вашу видеокамеру к телевизору с помощью соединительного кабеля аудио/видео. Затем, установите переключатель TV/VCR на Вашем телевизоре в положение VCR.

Playback - Basics

Воспроизведение - Основные положения

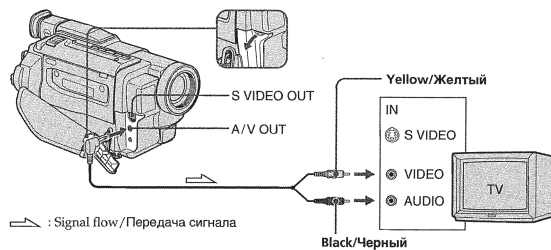

If your TV is already connected to a VCR

Connect your camcorder to the LINE IN input on the VCR by using the A/V connecting cable supplied with your camcorder. Set the input selector on the VCR to LINE.

Если Ваш телевизор уже подсоединен к КВМ

Подсоедините Вашу видеокамеру к входному гнезду LINE IN на КВМ с помощью соединительного кабеля аудио/видео, который прилагается к Вашей видеокамере. Установите селектор входного сигнала на КВМ в положение LINE.

41 42

Viewing the recording on TV

To connect to a TV without Video/Audio input jacks

Use a PAL system RFU adaptor (optional). Refer to the operating instructions of your TV and the RFU adaptor.

If your TV/VCR has a 21-pin connector (EUROCONNECTOR)

— CCD-TRV58E/TRV59E/TRV78E/TRV98E (European models only)
Use the 21-pin adaptor supplied with your camcorder.



If your TV has an S video jack

Connect using an S video cable (optional) to obtain high-quality pictures. With this connection, you do not need to connect the yellow (video) plug of the A/V connecting cable. Connect the S video cable (optional) to the S video jacks on both your camcorder and the TV.

Просмотр записи на экране телевизора

Для подсоединения к Вашему телевизору без входных гнезд аудио/видео

Используйте ВЧ-адаптер системы PAL (приобретается отдельно). Обратитесь к инструкции по эксплуатации Вашего телевизора и ВЧ-адаптера. При использовании ВЧ-адаптера звук будет монофоническим даже на стереофонических моделях.

Если в Вашем телевизоре/КВМ имеется 21-штырьковый разъем (EUROCONNECTOR)

— Только модели CCD-TRV58E/TRV59E/TRV78E/TRV98E (только европейские модели)
Используйте 21-штырьковый адаптер, прилагаемый к Вашей видеокамере.

Если в Вашем телевизоре имеется гнездо S видео
Выполните соединение с помощью кабеля S видео (не прилагается) для получения высококачественного изображения. При данном соединении Вам не нужно подсоединять желтый штекер (видео) соединительного кабеля аудио/видео. Подсоедините кабель S видео (не прилагается) к гнездам S видео на Вашей видеокамере и Вашем телевизоре.

Playback - Basics

Воспроизведение - Основные положения

— Advanced Recording Operation — Using the wide mode

You can record a cinema-like picture (CINEMA) or a 16:9 wide picture to watch on the 16:9 wide-screen TV (16:9FULL). Refer to the operating instructions of your TV.

CINEMA

Black bands appear on the screen during recording in the CINEMA mode [a], playing back on a normal TV [b] or a wide-screen TV [c]. If you set the screen mode of the wide-screen TV to the zoom mode, a picture without black bands appears [d].

16:9FULL

The picture during recording in the 16:9FULL mode [e], or playing back on a normal TV [f] or a wide-screen TV [g] is horizontally compressed. If you set the screen mode of the wide-screen TV to the full mode, you can watch pictures of normal images [h].

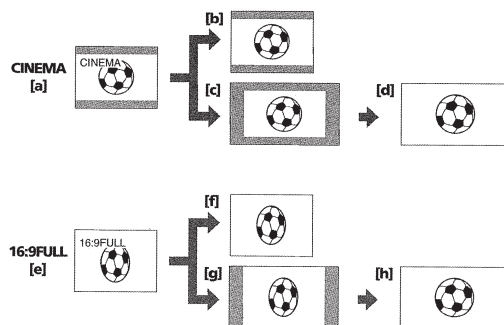

— Усовершенствованные операции съемки — Использование широкоэкранный режима

Вы можете записывать изображение наподобие кино (CINEMA) или широкоэкранный режим на широкоэкранный телевизор 16:9 (16:9FULL). Обратитесь к инструкции по эксплуатации Вашего телевизора.

CINEMA

Черные полосы появятся на экране во время записи в режиме CINEMA [a], воспроизведения на обычном телевизоре [b] или на широкоэкранный телевизор [c]. Если Вы установите экранный режим на широкоэкранный телевизор в режим масштабирования, то изображение появится без черных полос [d].

16:9FULL

Изображение во время записи в режиме 16:9 FULL [e], либо во время воспроизведения на обычном телевизоре [f] или широкоэкранный телевизор [g] будет сжато по горизонтали. Если Вы установите экранный режим широкоэкранный телевизор в полноэкранный режим, Вы можете просматривать изображения обычных съемок [h].

43 44

Using the wide mode

In CAMERA mode, set 16:9WIDE to CINEMA or 16:9FULL in **[C]** in the menu settings (p. 69).

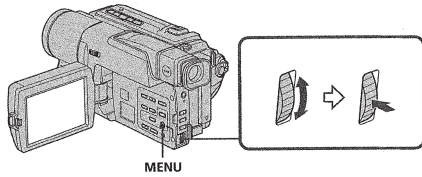

To cancel the wide mode

Set 16:9WIDE to OFF in the menu settings.

If the wide mode is set to 16:9FULL (CCD-TRV78E/TRV98E only)

The SteadyShot function does not work. If you select 16:9FULL in the menu settings when the SteadyShot function is working, **[S]** flashes and the SteadyShot function does not function.

In the wide mode

You cannot select the bounce function with FADER.

Date or time indicator

When you record in the 16:9FULL mode, the date or time indicator will be widened on wide-screen TVs.

During recording

You cannot change or cancel the wide mode. When you cancel the wide mode, set your camcorder to the standby mode and then set 16:9WIDE to OFF in the menu settings.

Использование широкоэкрannого режима

В режиме CAMERA установите 16:9WIDE положение CINEMA или 16:9FULL в установках меню (стр. 74).

Для отмены широкоэкрannого режима

Установите команду 16:9WIDE в положение OFF в установках меню.

Если широкоэкрannый режим установлен в положение 16:9FULL (Только модели CCD-TRV78E/TRV98E)

Функция устойчивой съемки не работает. Если Вы выберете команду 16:9FULL в установках меню в то время, когда работает функция устойчивой съемки, начнет мигать индикация "S", и функция устойчивой съемки работать не будет.

В широкоэкрannом режиме

Вы не можете выбрать функцию отскока с помощью кнопки FADER.

Индикатор даты или времени

Если Вы выполняете запись в режиме 16:9FULL, индикатор даты или времени расширится на широкоэкрannом телевизоре.

Во время записи

Вы не можете изменить или отменить широкоэкрannый режим. Для отмены широкоэкрannого режима установите Вашу видеокамеру на режим ожидания, а затем установите 16:9WIDE на OFF в установках меню.

Advanced Recording Operations

Усовершенствованные операции съемки

45 46

Using the fader function

You can fade in or out to give your recording a professional appearance.

Использование функции фейдера

Вы можете выполнять плавное введение и выведение изображения, чтобы придать Вашей съемке профессиональный вид.

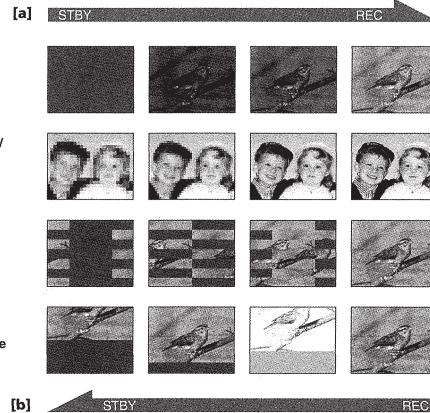

MONOTONE

When fading in, the picture gradually changes from black-and-white to colour. When fading out, the picture gradually changes from colour to black-and-white.

MONOTONE

При введении изображения будет постепенно изменяться от черно-белого до цветного. При выведении изображение будет постепенно изменяться от цветного до черно-белого.

Using the fader function

(1) When fading in [a]

In the standby mode, press FADER until the desired fader indicator flashes.

When fading out [b]

In the recording mode, press FADER until the desired fader indicator flashes. The indicator changes as follows:

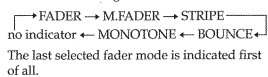

The last selected fader mode is indicated first of all.

(2) Press START/STOP. The fader indicator stops flashing.

After the fade in/out is carried out, your camcorder automatically returns to the normal mode.

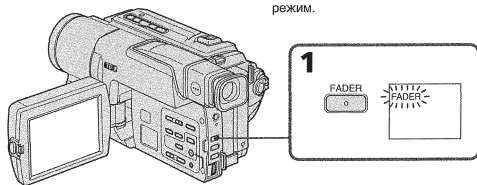

To cancel the fader function

Before pressing START/STOP, press FADER until the indicator disappears.

Использование функции фейдера

(1) При введении изображения [a]

В режиме ожидания, нажимайте кнопку FADER до тех пор, пока не начнет мигать нужный индикатор фейдера.

При выведении изображения [b]

В режиме записи, нажимайте кнопку FADER до тех пор, пока не начнет мигать нужный индикатор фейдера. Индикатор будет изменяться следующим образом:

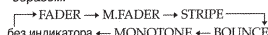

Последний из выбранных режимов фейдера отображается первым.

(2) Нажмите кнопку START/STOP. Индикатор фейдера перестанет мигать. После выполнения введения/выведения изображения Ваша видеокамера автоматически вернется в обычный режим.

Для отмены функции фейдера

Перед тем, как нажать кнопку START/STOP, нажимайте кнопку FADER до тех пор, пока не исчезнет индикатор.

Advanced Recording Operations

Усовершенствованные операции съемки

47 48

Using special effects – Picture effect

You can digitally process images to obtain special effects like those in films or on the TV.

- PASTEL [a]** : The contrast of the picture is emphasized, and the picture looks like an animated cartoon.
- NEG. ART [b]** : The colour and brightness of the picture are reversed.
- SEPIA** : The picture is sepia.
- B&W** : The picture is monochrome (black-and-white).
- SOLARIZE [c]** : The light intensity is clearer, and the picture looks like an illustration.
- MOSAIC [d]** : The picture is mosaic.
- SLIM [e]** : The picture expands vertically.
- STRETCH [f]** : The picture expands horizontally.

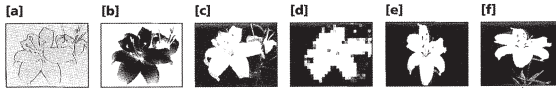

Использование специальных эффектов – Эффект изображения

Вы можете выполнять обработку изображения цифровым методом для получения специальных эффектов, как в кинофильмах или на экранах телевизоров.

- PASTEL [a]** : Подчеркивается контрастность изображения, которому придается мультипликационный вид.
- NEG. ART [b]** : Цвет и яркость изображения будут негативными.
- SEPIA** : Изображение будет в цвете сепии.
- B&W** : Изображение будет монохроматическим (черно-белым).
- SOLARIZE [c]** : Яркость света будет усиленной, а изображение будет выглядеть как иллюстрация.
- MOSAIC [d]** : Изображение будет мозаичным.
- SLIM [e]** : Изображение растянется по вертикали.
- STRETCH [f]** : Изображение растянется по горизонтали.

Using special effects – Picture effect

- (1) In CAMERA mode, select P EFFECT in in the menu settings. (p. 69).
- (2) Select the desired picture effect mode in the menu settings, then press the SEL/PUSH EXEC dial.

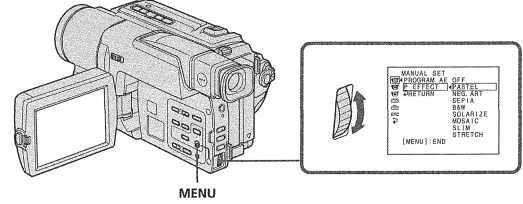

To turn the picture effect function off

Set P EFFECT to OFF in the menu settings.

When you turn the power off

Your camcorder automatically returns to the normal mode.

Использование специальных эффектов – Эффект изображения

- (1) В режиме CAMERA выберите пункт P EFFECT в разделе в установках меню. (стр. 74).
- (2) Выберите нужный режим эффекта изображения в установках меню, затем нажмите диск SEL/PUSH EXEC.

Для выключения функции эффекта изображения

Установите пункт P EFFECT в установках меню в положение OFF.

Если Вы выключите питание

Ваша видеокамера автоматически вернется в обычный режим.

Advanced Recording Operations

Совершенствование операции съемки

49 50

Using the PROGRAM AE function

You can select PROGRAM AE (Auto Exposure) mode to suit your specific shooting requirements.

Spotlight

This mode prevents people's faces, for example, from appearing excessively white when shooting subjects lit by strong light in the theatre.

Soft portrait

This mode brings out the subject while creating a soft background for subjects such as people or flowers.

Sports lesson

This mode minimizes shake on fast-moving subjects such as in tennis or golf.

Beach & ski

This mode prevents people's faces from appearing dark in strong light or reflected light, such as at a beach in midsummer or on a ski slope.

Sunset & moon

This mode allows you to maintain atmosphere when you are recording sunsets, general night views, fireworks displays and neon signs.

Landscape

This mode is for when you are recording distant subjects such as mountains and prevents your camcorder from focusing on glass or metal mesh in windows when you are recording a subject behind glass or a screen.

Использование функции PROGRAM AE

Вы можете выбрать режим PROGRAM AE (автоматическая съемка) в соответствии со специфическими требованиями к съемке.

Пржекторное освещение

Данный режим предотвращает, к примеру, лица людей от появления в чрезмерно белом свете при выполнении съемки людей, освещенных сильным светом на свадебных церемониях или в театре.

Мягкий портрет

Этот режим позволяет выделить объект на фоне мягкого фона, и подходит для съемки, например, людей или цветов.

Спортивные состязания

Этот режим позволяет минимизировать дрожание при съемке быстро движущихся предметов, например, при игре в теннис или гольф.

Пляжный и лыжный курорт

Этот режим предотвращает появление темных лиц людей в зоне сильного света или отраженного света, например, на пляже в разгар лета или на снежном склоне.

Заход солнца и луны

Этот режим позволяет в точности отражать обстановку при съемке заходов солнца, общих ночных видов, фейерверков и неоновых реклам.

Ландшафт

Этот режим позволяет выполнять съемку отдаленных объектов, таких как горы, например, и предотвращает фокусировку видеокамеры на стеклу или металлическую решетку на окнах, когда Вы выполняете запись объектов позади стекла или решетки.

Using the PROGRAM AE function

- (1) In CAMERA mode, select PROGRAM AE in in the menu settings (p. 69).
- (2) Select the desired PROGRAM AE mode in the menu settings, then press the SEL/PUSH EXEC dial.

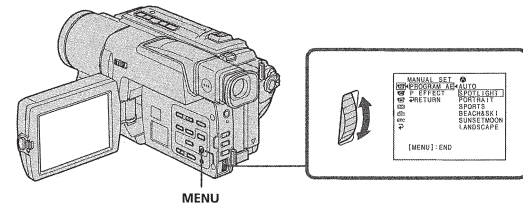

To turn the PROGRAM AE function off

Set PROGRAM AE to AUTO in the menu settings.

Использование функции PROGRAM AE

- (1) В режиме CAMERA выберите пункт PROGRAM AE в разделе в установках меню. (стр. 74).
- (2) Выберите нужный режим PROGRAM AE в установках меню, затем нажмите диск SEL/PUSH EXEC.

Для выключения функции PROGRAM AE

Установите пункт PROGRAM AE в установках меню в положение AUTO.

Advanced Recording Operations

Совершенствование операции съемки

51 52

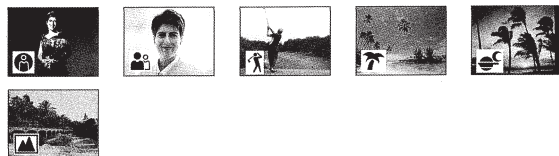

Using the PROGRAM AE function

Notes

- In the spotlight, sports lesson and beach & ski modes, you cannot take close-ups. This is because your camcorder is set to focus only on subjects in the middle to far distance.
- In the sunset & moon and landscape modes, your camcorder is set to focus only on distant subjects.
- The bounce function with FADER does not work in the PROGRAM AE mode.
- While setting NIGHTSHOT to ON, the PROGRAM AE function does not work. (The indicator flashes.)

If you are recording under a discharge tube such as a fluorescent lamp, sodium lamp or mercury lamp

Flickering or changes in colour may occur in the following modes. If this happens, turn the PROGRAM AE function off.
 – Soft portrait mode
 – Sports lesson mode

Использование функции PROGRAM AE

Примечания

- В режимах прожекторного освещения, спортивных состязаний, а также в пляжном и лыжном режиме Вы можете выполнять съемку крупным планом. Это объясняется тем, что Ваша видеокамера настроена для фокусировки только на объекты, находящиеся на среднем и дальнем расстояниях.
- В режиме захода солнца и луны, а также в ландшафтном режиме Ваша видеокамера настроена на фокусировку только на дальние объекты.
- Функция перекаивания с функцией FADER не работают в режиме PROGRAM AE.
- При установке переключателя NIGHTSHOT в положение ON функция PROGRAM AE не будет работать. (Индикатор мигает)

Если Вы выполняете запись при использовании газоразрядной лампы, натриевой лампы или ртутной лампы. В следующих режимах может возникнуть мерцание или неустойчивые процессы. Если это произойдет, выключите функцию PROGRAM AE.
 – Мягкий портретный режим
 – Режим спортивных состязаний

Advanced Recording Operations

Усовершенствованные операции съемки

Adjusting the exposure manually

You can manually adjust and set the exposure. Adjust the exposure manually in the following cases:

- The subject is backlit
- Bright subject and dark background
- To record dark pictures (e.g. night scenes) faithfully

- In CAMERA mode, press EXPOSURE. The exposure indicator appears.
- Turn the SEL/PUSH EXEC dial to adjust the brightness.

Регулировка экспозиции вручную

Вы можете отрегулировать и установить экспозицию вручную.

Отрегулируйте экспозицию вручную в следующих случаях:

- Объект на фоне задней подсветки
- Яркий объект на темном фоне
- Для записи темных изображений (например, ночных сцен) с большой достоверностью

- Нажмите кнопку EXPOSURE в режиме CAMERA. Появится индикатор экспозиции.
- Поверните диск SEL/PUSH EXEC для регулировки яркости.

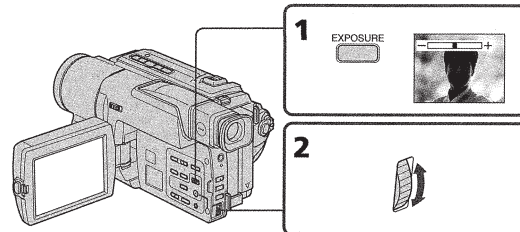

To return to the automatic exposure mode

Press EXPOSURE again.

Для возврата в режим автоматической экспозиции
 Нажмите кнопку EXPOSURE еще раз.

Note

When you adjust the exposure manually, the backlight function does not work.

Примечание

При выполнении регулировки экспозиции вручную функция задней подсветки не работает.

Your camcorder automatically returns to the automatic exposure mode:

- if you change the PROGRAM AE mode
- if you slide NIGHTSHOT to ON

Ваша видеокамера автоматически вернется в режим автоматической экспозиции:

- если Вы измените режим PROGRAM AE
- если Вы переведете переключатель NIGHTSHOT в положение ON

53 54

Focusing manually

You can gain better results by manually adjusting the focus in the following cases:

- The autofocus mode is not effective when shooting
 - subjects through glass coated with water droplets
 - horizontal stripes
 - subjects with little contrast with backgrounds such as walls and sky
- When you want to change the focus from a subject in the foreground to a subject in the background
- Shooting a stationary subject when using a tripod

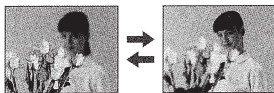

- In CAMERA mode, press FOCUS. The ∞ indicator appears.
- Turn the SEL/PUSH EXEC dial to sharpen focus.

Фокусировка вручную

Вы можете получить лучшие результаты путем регулировки вручную в следующих случаях:

- Режим автоматической фокусировки является неэффективным при выполнении съемки
 - объектов через стекло, покрытое каплями воды
 - горизонтальных полос
 - объектов с малой контрастностью на таком фоне, как стена или небо
- Если Вы хотите выполнить изменение фокусировки с объекта на переднем плане на объект на заднем плане
- При выполнении съемки стационарных объектов с использованием триеноги

- Нажмите кнопку FOCUS в режиме CAMERA. Появится индикатор ∞ .
- Поверните диск SEL/PUSH EXEC для получения четкой фокусировки.

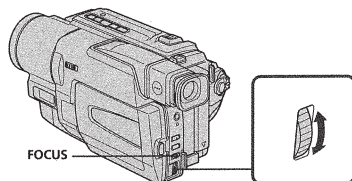

To return to the autofocus mode

Press FOCUS.

Для возвращения в режим автоматической фокусировки
 Нажмите кнопку FOCUS.

Advanced Recording Operations

Усовершенствованные операции съемки

Focusing manually

To focus precisely

Adjust the zoom by first focusing at the "T" (telephoto) position and then shooting at the "W" (wide-angle) position. This makes focusing easier.

When you shoot close to the subject
 Focus at the end of the "W" (wide-angle) position.

- ∞ changes to the following indicators:
 - ▲ When recording a distant subject.
 - When the subject is too close to focus on.

Фокусировка вручную

Для точной фокусировки

Отрегулируйте вариообъектив, сначала выполнив фокусировку в положении "Т" (телефото), а затем выполнив съемку в положении "W" (широкого угла охвата). Это упростит фокусировку.

Если Вы выполняете съемку вблизи объекта

Выполните фокусировку в конце положения "W" (широкоугольное).

Индикатор ∞ будет изменяться на следующие индикаторы:

- ▲ при записи удаленного объекта.
- при записи объекта, расположенного слишком близко к фокусу.

55 56

Superimposing a title

You can select one of eight preset titles and two custom titles (p. 59). You can also select the language, colour, size and position of titles.



- In CAMERA mode, press TITLE to display the title menu.
- Turn the SEL/PUSH EXEC dial to select , then press the dial.
- Select the desired title in the menu settings, then press the SEL/PUSH EXEC dial.
- Change the colour, size, or position, if necessary.
 - Turn the SEL/PUSH EXEC dial to select the colour, size, or position, then press the dial. The item appears.
 - Turn the SEL/PUSH EXEC dial to select the desired item, then press the dial.
 - Repeat steps ① and ② until the title is laid out as desired.
- Press the SEL/PUSH EXEC dial again to complete the setting.
- Press START/STOP to start recording.
- When you want to stop recording the title, press TITLE.

Наложение титра

Вы можете выбрать один из восьми предварительно установленных титров и два созданных Вами титра (стр. 59). Вы можете также выбрать язык, цвет, размер и положение титров.

- В режиме CAMERA, нажмите кнопку TITLE для отображения меню титров.
- Поверните диск SEL/PUSH EXEC для выбора индикации , а затем нажмите диск.
- Выберите нужный титр в установках меню, затем нажмите диск SEL/PUSH EXEC.
- Измените цвет, размер или положение титра, если нужно.
 - Поверните диск SEL/PUSH EXEC для выбора цвета, размера или положения титра, а затем нажмите диск. Появится нужный пункт.
 - Поверните диск SEL/PUSH EXEC для выбора нужного пункта, а затем нажмите диск.
 - Повторяйте пункты ① и ② до тех пор, пока титр не будет расположен, как нужно.
- Нажмите диск SEL/PUSH EXEC еще раз для завершения установки.
- Нажмите кнопку START/STOP для начала записи.
- Если Вы хотите остановить запись титра, нажмите кнопку TITLE.

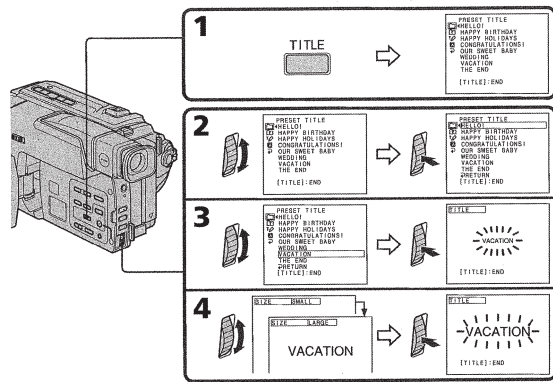

Advanced Recording Operations

Усовершенствованные операции съемки

Superimposing a title

To superimpose the title while you are recording

Press TITLE while you are recording, and carry out steps 2 to 5. When you press the SEL/PUSH EXEC dial at step 5, the title is superimposed.

To select the language of a preset title

If you want to change the language, select before step 2. Then select the desired language and return to step 2.

Note

Both the date and time or either of them may not be displayed depending on the size or position of the title.

If you display the menu or title menu while superimposing a title

The title is not recorded while the menu or title menu is displayed.

To use the custom title

If you want to use the custom title, select in step 2.

Title setting

- The title colour changes as follows: WHITE ↔ YELLOW ↔ VIOLET ↔ RED ↔ CYAN ↔ GREEN ↔ BLUE
- The title size changes as follows: SMALL ↔ LARGE

You cannot input 13 characters or more in LARGE size.

- The title position changes as follows: 1 ↔ 2 ↔ 3 ↔ 4 ↔ 5 ↔ 6 ↔ 7 ↔ 8 ↔ 9

The larger the position number, the lower the title is positioned.

When you select the title size "LARGE", you cannot choose position 9.

When you select the title size "LARGE" in the CINEMA mode, you cannot choose position 8 nor 9.

When you are selecting and setting the title You cannot superimpose the title displayed on the screen.

When you superimpose a title while you are recording The beep does not sound.

57 58

Making your own titles

You can make up to two titles and store them in your camcorder. Each title can have up to 20 characters.

- In CAMERA or PLAYER mode, press TITLE.
- Turn the SEL/PUSH EXEC dial to select , then press the dial.
- Turn the SEL/PUSH EXEC dial to select the first line (CUSTOM1 SET) or second line (CUSTOM2 SET), then press the dial.
- Turn the SEL/PUSH EXEC dial to select the column of the desired character, then press the dial.
- Turn the SEL/PUSH EXEC dial to select the desired character, then press the dial.
- Repeat steps 4 and 5 until you have selected all characters and completed the title.
- To finish making your own titles, turn the SEL/PUSH EXEC dial to select [SET], then press the dial. The title is stored in memory.
- Press TITLE to make the title menu disappear.

Создание своих собственных титров

Вы можете создать два собственных титра и хранить их в памяти видеокамеры. Каждый титр может состоять из 20 символов.

- В режиме CAMERA или PLAYER, нажмите кнопку TITLE.
- Поверните диск SEL/PUSH EXEC для выбора индикации , а затем нажмите диск.
- Поверните диск SEL/PUSH EXEC для выбора первой строки (CUSTOM1 SET) или второй строки (CUSTOM2 SET), а затем нажмите диск.
- Поверните диск SEL/PUSH EXEC для выбора колонки с нужным символом, а затем нажмите диск.
- Поверните диск SEL/PUSH EXEC нужного символа, а затем нажмите диск.
- Повторяйте действия пунктов 4 и 5 до тех пор, пока не выберите все символы и не составите полностью титр.
- Для завершения создания своих собственных титров поверните диск SEL/PUSH EXEC для выбора команды [SET], а затем нажмите диск. Титр будет занесен в память.
- Нажмите кнопку TITLE, чтобы меню титров исчезло.

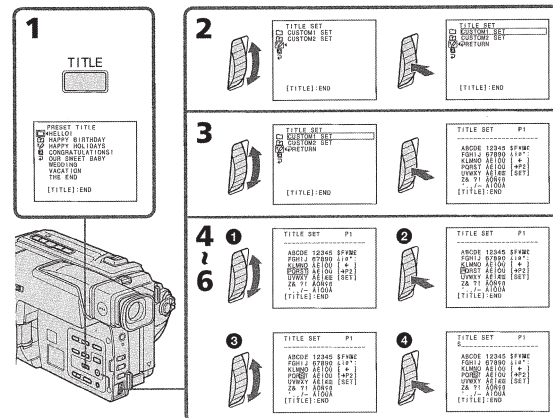

Advanced Recording Operations

Усовершенствованные операции съемки

Making your own titles

To change a title you have stored

In step 3, select CUSTOM1 SET or CUSTOM2 SET, depending on which title you want to change, then press the SEL/PUSH EXEC dial. Turn the SEL/PUSH EXEC dial to select , then press the dial to delete the title. The last character is erased. Enter the new title as desired.

If you take 5 minutes or longer to enter characters in the standby mode while a cassette is in your camcorder

The power automatically turns off. The characters you have entered remain stored in memory. Set the POWER switch to OFF (CHARGE) once, and turn it to CAMERA again, then proceed from step 1.

We recommend setting the POWER switch to PLAYER or removing the cassette so that your camcorder does not automatically turn off while you are entering title characters.

If you select [→P2]

The menu for selecting alphabet and Russian characters appears. Select [→P1] to return to the previous screen.

To delete the title

Select . The last character is erased.

To enter a space

Select [Z& ?!], then select the blank part.

Наложение титра

Для наложения титра во время записи

Нажмите кнопку TITLE во время записи и выполните действия пунктов со 2 по 5. Если Вы нажмете кнопку SEL/PUSH EXEC в пункте 5, титр будет наложен на изображение.

Для выбора языка предварительно установленного титра

Если Вы хотите изменить язык, выберите индикацию перед выполнением действия пункта 2. Затем выберите нужный язык и вернитесь к пункту 2.

Примечание

Индикация даты и времени или же одна из них не могут отображаться на дисплее в зависимости от размера или положения титра.

Если на дисплее отображается меню или меню титров во время наложения титра Титр не записывается во время отображения на дисплее меню или меню титров.

Для использования созданного Вами титра

Если Вы хотите использовать созданный Вами титр, выберите индикацию в пункте 2.

Установка титра

Цвет титра изменяется следующим образом: WHITE (БЕЛЫЙ) ↔ YELLOW (ЖЕЛТЫЙ) ↔ VIOLET (ФИОЛЕТОВЫЙ) ↔ RED (КРАСНЫЙ) ↔ CYAN (ГОЛУБОЙ) ↔ GREEN (ЗЕЛЕННЫЙ) ↔ BLUE (СИНИЙ)

Размер титра изменяется следующим образом: SMALL (МАЛЕНЬКИЙ) ↔ LARGE (БОЛЬШОЙ) Вы не можете ввести 13 знаков или более при размере LARGE.

Положение титра изменяется следующим образом: 1 ↔ 2 ↔ 3 ↔ 4 ↔ 5 ↔ 6 ↔ 7 ↔ 8 ↔ 9 Чем больше номер положения титра, тем ниже будет расположен титр.

Если Вы выберите размер "LARGE", Вы не сможете изменять положения 9.

Если Вы выберите размер титра "LARGE" в режиме CINEMA, Вы не сможете выбрать ни положение 8, ни положение 9.

Во время выбора и установки титра

Вы не можете налагать на изображение титр, отображаемый на экране.

При наложении титра во время записи

Зуммерного сигнала не будет.

Создание своих собственных титров

Для изменения сохраненного в памяти титра

В пункте 3, выберите команду CUSTOM1 SET или CUSTOM2 SET в зависимости от того, какой титр Вы хотите изменить, а затем нажмите диск SEL/PUSH EXEC. Поверните диск SEL/PUSH EXEC для выбора индикации , а затем нажмите диск для удаления титра. Последний символ будет удален. Введите новый нужный символ.

Если при вводе символов пройдет 5 минут или более в режиме ожидания при вставленной кассете в Вашу видеокамеру Питание автоматически выключится.

Введенные символы будут сохранены в памяти. Установите переключатель POWER сначала в положение OFF (CHARGE), снова верните его в положение CAMERA, а затем продолжите с пункта 1.

Рекомендуется установить переключатель POWER в положение PLAYER или вынуть кассету, чтобы Ваша видеокамера автоматически не выключалась при вводе символов титра.

Если Вы выбрали команду [→P2]

Появится меню для выбора алфавита и русских букв. Выберите команду [→P1], чтобы вернуться к предыдущему экрану.

Для удаления титра

Выберите команду . Последний символ будет удален.

Для ввода пробела

Нажмите клавиши [Z& ?!], а затем выберите чистую часть.

59 60

Using the built-in light

You can use the built-in light to suit your shooting situation. The recommended distance between the subject and camcorder is about 1.5 m (5 feet).

Press LIGHT until the  indicator appears on the screen while your camcorder is in CAMERA mode. The built-in light turns on. If you turn the POWER switch to OFF (CHARGE), the built-in light turns off simultaneously. You cannot turn the built-in light on by turning the POWER switch to CAMERA again. To turn on the built-in light again, press LIGHT again in CAMERA mode.

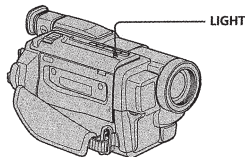

LIGHT

To turn off the built-in light

Press LIGHT until no indicator appears on the screen.

To turn on the built-in light automatically

Press LIGHT until the  indicator appears on the screen. The built-in light automatically turns on and off according to the ambient brightness.

Использование встроенной подсветки

Вы можете использовать встроенную подсветку в соответствии с условиями съемки. Рекомендуемое расстояние между объектом и видеокамерой равно около 1,5 м.

Нажимайте кнопку LIGHT в то время, когда видеокамера находится в режиме CAMERA до тех пор, пока индикатор  не появится на экране. Высветится встроенная подсветка. Если Вы повернете переключатель POWER в положение OFF (CHARGE), встроенная подсветка одновременно погаснет. Вы не сможете включить встроенную подсветку, снова повернув переключатель POWER в положение CAMERA. Для включения встроенной подсветки, нажмите снова кнопку LIGHT в режиме CAMERA.

Для выключения встроенной подсветки

Нажимайте кнопку LIGHT до тех пор, пока на экране не останется никакого индикатора.

Для автоматического включения встроенной подсветки

Нажимайте кнопку LIGHT до тех пор, пока индикатор  появится на экране. Встроенная подсветка будет автоматически включаться и выключаться в соответствии с яркостью окружающей среды.

Advanced Recording Operations
Усовершенствованные операции съемки

Using the built-in light

CAUTION

Be careful not to touch the lighting section, because the plastic window and surrounding surfaces are hot while the light is on. It remains hot for a while after the light is turned off.

DANGER

Not to be handled by children. Emits intense heat and light. Use with caution to reduce the risk of fire or injury to persons. Do not directly light at persons or materials from less than 1.22 m (4 feet) during use and until cool. Turn the built-in light off when not in use.

When you press LIGHT

The indicator changes as follows:



Notes

- The built-in light turns off automatically in the following cases:
 - When it stays on in the AUTO mode for more than 5 minutes.
 - When you leave it on for more than 5 minutes with no cassette inserted or after the tape has run out.
- To turn the built-in light on again, press LIGHT again.
- The battery pack is quickly discharging while the built-in light is turned on. Turn it off when not in use.
- When you do not use your camcorder, turn the built-in light off and remove the battery pack to avoid turning on the built-in light accidentally.
- When flickering occurs while shooting in the AUTO mode, press LIGHT until the  indicator appears.
- The built-in light may turn on/off when you use the PROGRAM AE or backlight function while shooting in the AUTO mode.

Использование встроенной подсветки

ВНИМАНИЕ

Будьте осторожны, чтобы не прикасаться к секции подсветки, поскольку пластмассовое окно и прилегающая поверхность являются горячими при включенной подсветке. Эта секция будет оставаться горячей и некоторое время после выключения подсветки.

ОСТОРОЖНО

Детям пользоваться аппаратом запрещено. Он излучает сильное тепло и свет.

Соблюдайте осторожность, чтобы не допустить случайного воспламенения предметов и не травмировать людей вокруг.

Не направляйте подсветку на людей или материалы с расстояния менее 1,22 м во время пользования аппаратом и до его остывания.

Выключите встроенную подсветку, если аппарат не используется.

При нажатии кнопки LIGHT

Индикатор изменяется, как



Примечания

- Встроенная подсветка выключается автоматически в следующих случаях:
 - Если она остается включенной в режиме AUTO более, чем на 5 минут.
 - Если Вы оставляете ее включенной более чем на 5 минут, когда кассета не установлена или достигнут конец ленты.
- Чтобы включить встроенную подсветку снова, нажмите кнопку LIGHT еще раз.
- Батарейный блок быстро разряжается при включенной подсветке. Выключите ее, если аппарат не используется.
- Если Вы не используете Вашу видеокамеру, выключите встроенную подсветку и снимите батарейный блок во избежание случайного включения встроенной подсветки.
- В случае появления мерцания во время съемки в режиме AUTO нажимайте кнопку LIGHT, пока не появится индикатор .
- Встроенная подсветка может включаться/выключаться при использовании функции PROGRAM AE или функции задней подсветки во время съемки в AUTO режиме.

61 62

Using the built-in light

- The built-in light may be turned off when inserting or ejecting a cassette.
- While the end search function is working, the built-in light is turned off.
- When you use the conversion lens (optional) light from the built-in light is blocked and may not illuminate the subject properly.

Replacing the bulb

Use the Sony XB-3D halogen lamp (optional). The supplied halogen lamp is not on the market. Purchase the Sony XB-3D halogen lamp. Remove the power source before replacing the bulb.

- Remove the built-in light unit while pushing the hole under the built-in light unit using a wire.
- Turn the bulb housing counterclockwise and detach from the built-in light unit.
- Replace the bulb using a dry cloth.
- Attach the bulb housing turning it clockwise, then replace the built-in light unit.

Использование встроенной подсветки

- Встроенная подсветка может выключаться при установке или извлечении кассеты.
- При использовании функции поиска конца записи на ленте встроенная подсветка выключается.
- Если Вы используете преобразовательный объектив (приобретается отдельно), лампа встроенной подсветки блокируется и может не обеспечивать освещение объекта надлежащим образом.

Замена лампы накаливания

Используйте галогенную лампу Sony XB-3D (приобретается отдельно). Прилагаемая галогенная лампа не поступает в розничную продажу. Приобретите галогенную лампу Sony XB-3D. Перед заменой лампы накаливания выньте источник питания.

- Выньте встроенное устройство подсветки, нажав на отверстие под встроенным устройством с помощью проволоки.
- Поверните корпус лампы накаливания против часовой стрелки и отсоедините лампу от встроенного устройства подсветки.
- Отсоедините лампу накаливания с помощью сухой ткани.
- Прикрепите корпус лампы накаливания, повернув его по часовой стрелке, и замените встроенное устройство подсветки.

Advanced Recording Operations
Усовершенствованные операции съемки

Using the built-in light

CAUTION

- When replacing the bulb, use only the Sony XB-3D halogen lamp (optional) to reduce the risk of fire.
- To prevent possible burn hazard, disconnect the power source before replacing and do not touch the bulb until the bulb becomes cool enough to handle (for about 30 minutes or more).

Note

To prevent the bulb from being smudged with finger prints, handle it with a dry cloth, etc. If the bulb is smudged, wipe it completely.

Использование встроенной подсветки

ВНИМАНИЕ

- При замене лампы накаливания используйте только галогенную лампу Sony XB-3D (приобретается отдельно) для уменьшения вероятности воспламенения.
- Для предотвращения опасности получения ожога, отсоедините источник питания перед тем, как заменить лампу накаливания, и не прикасайтесь к лампе до тех пор, пока она достаточно не остынет (около 30 минут или более).

Примечание

Для предотвращения загрязнения лампы накаливания от отпечатков пальцев обращайтесь с ней осторожно, используя сухую ткань. В случае загрязнения лампы накаливания тщательно протрите ее.

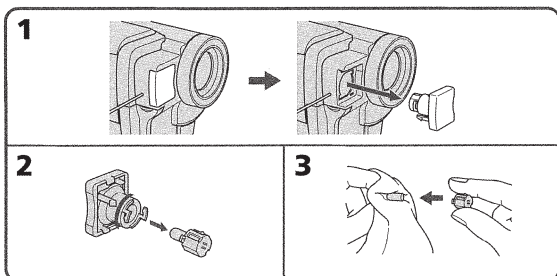

63 64

Dubbing a tape

Using the A/V connecting cable

Connect your camcorder to the VCR using the A/V connecting cable supplied with your camcorder.

You can record and edit a picture with the connected VCR by using your camcorder as a player.

Make the indicators disappear by pressing DISPLAY. If you do not make the indicators disappear, they are recorded on tapes.

- (1) Insert a blank tape (or a tape you want to record over) into the VCR, and insert the recorded tape into your camcorder.
- (2) Set the input selector on the VCR to LINE. Refer to the operating instructions of your VCR for more information.
- (3) Set the POWER switch to PLAYER.
- (4) Play back the recorded tape on your camcorder.
- (5) Start recording on the VCR. Refer to the operating instructions of your VCR for more information.

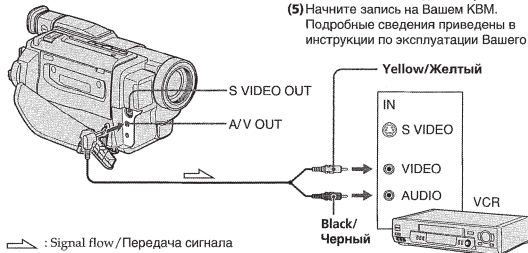

When you have finished dubbing a tape

Press **■** on both your camcorder and the VCR.

To prevent deterioration of pictures when dubbing

Set EDIT to ON in the menu settings before dubbing.

Перезапись ленты

Использование соединительного шнура аудио/видео

Подсоедините Вашу видеокамеру к КВМ с помощью соединительного кабеля аудио/видео, который прилагается к Вашей видеокамере.

Вы можете записывать и монтировать изображение на присоединенном КВМ, используя Вашу видеокамеру в качестве плеера.

Отключите индикаторы, нажав кнопку DISPLAY. Если Вы не отключите индикаторы, они будут записаны на ленте.

- (1) Вставьте незаписанную ленту (или ленту, на которую Вы хотите выполнить запись) в КВМ и вставьте записанную ленту в Вашу видеокамеру.
- (2) Установите селектор входного сигнала на КВМ в положение LINE. Подробные сведения приведены в инструкции по эксплуатации Вашего КВМ.
- (3) Установите переключатель POWER в положение PLAYER.
- (4) Начните воспроизведение записанной ленты на Вашей видеокамере.
- (5) Начните запись на Вашем КВМ. Подробные сведения приведены в инструкции по эксплуатации Вашего КВМ.

Editing

Монтаж

Dubbing a tape

You can edit on VCRs that support the following systems

8 mm, Hi8 Hi8, i Digital8, VHS VHS, S-VHS S-VHS, Hi8 Hi8, i Digital8, VHS VHS, S-VHS S-VHS, Betamax, mini DV or DV DV

Connect using an S video cable (optional) to obtain high-quality pictures

With this connection, you do not need to connect the yellow (video) plug of the A/V connecting cable.

Connect an S video cable (optional) to the S video jacks of both your camcorder and the VCR.

Перезапись ленты

Вы можете выполнять монтаж на КВМ, которые поддерживают следующие системы

8 мм, Hi8 Hi8, i Digital8, VHS VHS, S-VHS S-VHS, Hi8 Hi8, i Digital8, VHS VHS, S-VHS S-VHS, Betamax, mini DV или DV DV

Выполните подсоединение с помощью кабеля S видео (не прилагается) для получения высококачественных изображений

При таком подсоединении Вам не нужно подсоединять желтый (видео) штекер соединительного кабеля аудио/видео. Подсоедините кабель S видео (не прилагается) к гнездам S видео на Вашей видеокамере и КВМ.

Changing the menu settings

To change the mode settings in the menu settings, select the menu items with the SEL/PUSH EXEC dial. The default settings can be partially changed. First, select the icon, then the menu item and then the mode.

- (1) In CAMERA or PLAYER mode, press MENU.
- (2) Turn the SEL/PUSH EXEC dial to select the desired icon, then press the dial to set.
- (3) Turn the SEL/PUSH EXEC dial to select the desired mode, and press the dial to set.
- (4) Turn the SEL/PUSH EXEC dial to select the desired mode, and press the dial to set.
- (5) If you want to change other items, select RETURN and press the dial, then repeat steps from 2 to 4.

For details, see "Selecting the mode setting of each item" (p. 69).

Изменение установок меню

Для изменения установок режима в установках меню выберите пункты меню с помощью диска SEL/PUSH EXEC. Установки по умолчанию могут быть частично изменены. Сначала выберите пиктограмму, затем пункт меню, а затем режим.

- (1) в режиме CAMERA или режиме PLAYER нажмите кнопку MENU.
- (2) Поверните диск SEL/PUSH EXEC для выбора нужной пиктограммы, а затем нажмите диск для установки.
- (3) Поверните диск SEL/PUSH EXEC для выбора нужной пиктограммы, а затем нажмите диск для установки.
- (4) Поверните диск SEL/PUSH EXEC для выбора нужной пиктограммы, а затем нажмите диск для установки.
- (5) Если Вы хотите изменить другие пункты, выберите команду RETURN, а затем нажмите диск, после чего повторите действия пунктов со 2 по 4. Подробные сведения приведены в разделе "Выбор установок режима по каждому пункту" (стр. 74)

Customizing Your Camcorder

Выполнение индивидуальных установок на видеокамере

Changing the menu settings

Изменение установок меню

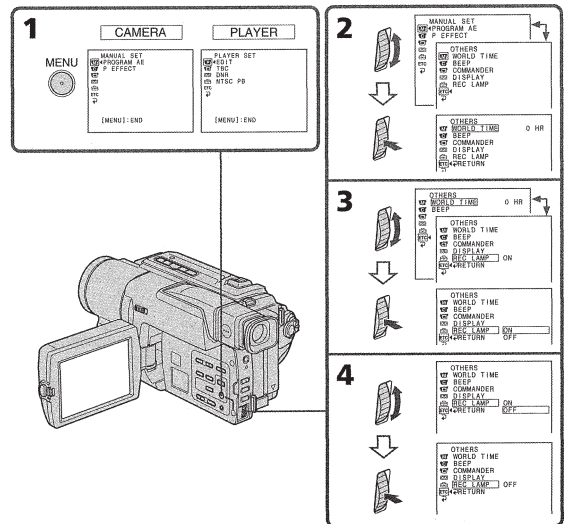

To make the menu display disappear
Press MENU.

Для того, чтобы исчезла индикация меню
Нажмите кнопку MENU.

Changing the menu settings

Menu items are displayed as the following icons:

- MANUAL SET
- CAMERA SET
- PLAYER SET
- LCD SET
- TAPE SET
- SETUP MENU
- OTHERS

Depending on your camcorder model
The menu display may be different from that in this illustration.

Изменение установок меню

Пункты меню отображаются в виде шести, приведенных ниже, пиктограмм:

- MANUAL SET
- CAMERA SET
- PLAYER SET
- LCD SET
- TAPE SET
- SETUP MENU
- OTHERS

В зависимости от модели Вашей видеокамеры
Меню индикации может отличаться от указанной на рисунке.

English

Setting the mode setting of each item ● is the default setting.

Menu items differ according to the position of the POWER switch. The screen shows only the items you can operate at the moment.

Icon/item	Mode	Meaning	POWER switch
PROGRAM AE	—	To suit your specific shooting requirement (p. 51)	CAMERA
P EFFECT	—	To add special effects like those in films or on the TV to images (p. 49).	CAMERA
D ZOOM	● OFF	If you set to OFF, digital zoom is deactivated and up to 20x is carried out. If you set to 40x/450x, digital zoom is activated and more than 20x to 40x/450x is performed digitally. (p. 30) (CCD-TRV49E only)	CAMERA
	● OFF	If you set to OFF, digital zoom is deactivated and up to 20x is carried out. If you set to 40x/460x, digital zoom is activated and more than 20x to 40x/460x is performed digitally. (p. 30) (CCD-TRV58E only)	
	● OFF	If you set to OFF, digital zoom is deactivated and up to 20x is carried out. If you set to 40x/560x, digital zoom is activated and more than 20x to 40x/560x is performed digitally. (p. 30) (CCD-TRV59E/TRV78E/TRV98E only)	
16:9WIDE	● OFF	—	CAMERA
	CINEMA	To record in the CINEMA mode (p. 44)	
	16:9FULL	To record in the 16:9FULL mode	
STEADYSHOT*	● ON	To compensate for camera-shake	CAMERA
	OFF	To cancel the SteadyShot function. Natural pictures are produced when shooting a stationary object with a tripod.	
N.S. LIGHT	● ON	To use the NightShot Light function (p. 34)	CAMERA
	OFF	To cancel the NightShot Light function	

* CCD-TRV78E/TRV98E only

Customizing Your Camcorder

Выполнение индивидуальных установок на видеокамере

69 70

Changing the menu settings

Icon/item	Mode	Meaning	POWER switch
REC MODE	● SP	To record in SP (Standard Play) mode	CAMERA
	LP	To increase the recording time to twice the SP mode	
ORC TO SET	—	To automatically adjust the recording condition to get the best possible recording. Press START/STOP to start adjustment. Your camcorder takes about 10 seconds to check the tape condition and then returns to the standby mode.	CAMERA
ORC stands for "Optimizing the Recording Condition".			
REMAIN	● AUTO	To display the remaining tape bar: • for about 8 seconds after your camcorder is turned on and calculates the remaining amount of tape • for about 8 seconds after a cassette is inserted and your camcorder calculates the remaining amount of tape • for about 8 seconds after ► is pressed in PLAYER mode • for about 8 seconds after DISPLAY is pressed to display the screen indicators • for the period of tape rewinding, forwarding or picture search in the PLAYER mode	PLAYER CAMERA
	ON	To always display the remaining tape bar	

Notes on the LP mode

- When you record a tape in the LP mode on your camcorder, we recommend playing back the tape on your camcorder. When you play back the tape on other camcorders or VCRs, noise may occur in pictures or sound.
- Noise may occur also when you play on your camcorder tapes recorded in the LP mode on other camcorders or VCRs.

Notes on ORC setting

- Each time you eject the cassette, the ORC setting will be canceled. If necessary, reset the setting.
- You cannot use this setting on a tape with the red mark on the cassette exposed. (i. e. the tape is write-protected)
- When you set ORC TO SET, a non-recorded section of about 0.1 seconds appears on the tape. However, note that this non-recorded section disappears from the tape when you continue recording from this section.
- To check if you have already set the ORC setting, select ORC TO SET in the menu settings. "ORC ON" is displayed if ORC TO SET is already set.

Customizing Your Camcorder

Выполнение индивидуальных установок на видеокамере

71 72

Changing the menu settings

Icon/item	Mode	Meaning	POWER switch
EDIT	● OFF	—	PLAYER
	ON	To minimize picture deterioration when editing	
TBC	● ON	To correct jitter	PLAYER
	OFF	To not correct jitter. Set TBC to OFF when playing back a tape on which you have dubbed over and recorded the signal of a TV game or similar machine.	
TBC stands for "Time Base Corrector".			
DNR	● ON	To reduce picture noise	PLAYER
	OFF	To reduce a conspicuous afterimage when the picture has a lot of movement	
DNR stands for "Digital Noise Reduction".			
NTSC PB	● ON PAL TV	To play back a tape recorded in the NTSC colour system on a PAL system TV	PLAYER
	NTSC 4.43	To play back a tape recorded in the NTSC colour system on a TV with the NTSC 4.43 mode	
LCD BRIGHT	—	To adjust the brightness on the LCD screen with the SEL/PUSH EXEC dial.	PLAYER CAMERA
		 To darken ← To lighten →	
LCD B. L.	● BRT NORMAL	To set the brightness on the LCD screen normal	PLAYER CAMERA
	BRIGHT	To brighten the LCD screen	
LCD COLOUR	—	To adjust the colour on the LCD screen	PLAYER CAMERA
		 To reduce intensity ← To increase intensity →	

Notes on the SteadyShot function (CCD-TRV78E/TRV98E only)

- The SteadyShot function will not correct excessive camera-shake.
- Attachment of a conversion lens (optional) may influence the SteadyShot function.
- SteadyShot does not operate in the 16:9FULL mode. If you set STEADYSHOT to ON in the menu settings, the indicator flashes.

If you cancel the SteadyShot function (CCD-TRV78E/TRV98E only)

The SteadyShot off indicator appears. Your camcorder prevents excessive compensation for camera-shake.

Note on the playback of the NTSC tapes

You can play back tapes recorded in the NTSC video system. When you play back a tape on a Multi System TV, select the best mode while viewing the picture on the TV.

In more than 5 minutes after removing the power source

The "EDIT" and "COMMANDER" (CCD-TRV49E/TRV59E/TRV78E/TRV98E only) items are returned to their default settings.

The other menu items are held in memory even when the battery is removed.

Note on LCD B.L.

When you use power sources other than the battery pack, "BRIGHT" is automatically selected.

Changing the menu settings

Icon/item	Mode	Meaning	POWER switch
CLOCK SET	—	To set the date or time (p. 22)	CAMERA
AUTO DATE	● ON	To record the date for 10 seconds after recording has started	CAMERA
	OFF	To cancel the auto date function	
LTR SIZE	● NORMAL	To display selected menu items in normal size	PLAYER CAMERA
	2x	To display selected menu items at twice the normal size	
DEMO MODE	● ON	To make the demonstration appear	CAMERA
	OFF	To cancel the demonstration mode	

Notes on DEMO MODE

- You cannot select DEMO MODE when a cassette is inserted in your camcorder.
- DEMO MODE is set to STBY (Standby) at the factory and the demonstration starts about 10 minutes after you have set the POWER switch to CAMERA without a cassette inserted. To cancel the demonstration, insert a cassette, set the POWER switch to other than CAMERA, or set DEMO MODE to OFF.
- When NIGHTSHOT is set to ON, the "NIGHTSHOT" indicator appears on the screen and you cannot select DEMO MODE in the menu settings.

Changing the menu settings

Icon/item	Mode	Meaning	POWER switch
WORLD TIME	---	To set the clock to the local time. Turn the SEL / PUSH EXBC dial to set a time difference. The clock changes by the time difference you set here. If you set the time difference to 0, the clock returns to the originally set time.	CAMERA
BEEP	● MELODY	To output the melody when you start/stop recording or when an unusual condition occurs on your camcorder	PLAYER CAMERA
	NORMAL	To output the beep sound instead of the melody	
	OFF	To cancel the melody and beep sound	
COMMANDER*	● ON	To activate the Remote Commander supplied with your camcorder	PLAYER CAMERA
	OFF	To deactivate the Remote Commander to avoid remote control misoperation caused by other VCR's remote control	
DISPLAY	● LCD	To show the display on the LCD screen and viewfinder	PLAYER CAMERA
	V-OUT/LCD	To show the display on the TV screen, LCD screen and viewfinder	
REC LAMP	● ON	To light up the camera recording lamp at the front of your camcorder	CAMERA
	OFF	To turn the camera recording lamp off so that the subject is not aware of the recording	

* CCD-TRV49E/TRV59E/TRV78E/TRV98E only

— Troubleshooting —

English

Types of trouble and their solutions

If you run into any problem using your camcorder, use the following table to troubleshoot the problem. If the problem persists, disconnect the power source and contact your Sony dealer or local authorized Sony service facility. If "C:□□:□□" appears on the screen, the self-diagnosis display function has worked. See page 83.

In the recording mode

Symptom	Cause and/or Corrective Actions
START/STOP does not operate.	<ul style="list-style-type: none"> The POWER switch is set to OFF (CHARGE) or PLAYER. <ul style="list-style-type: none"> → Set it to CAMERA. (p. 26) The tape has run out. <ul style="list-style-type: none"> → Rewind the tape or insert a new one. (p. 24, 38) The write-protect tab is set to expose the red mark. <ul style="list-style-type: none"> → Use a new tape or slide the tab. (p. 24) The tape is stuck to the drum (moisture condensation). <ul style="list-style-type: none"> → Remove the cassette and leave your camcorder for at least 1 hour to acclimatize. (p. 98)
The power goes off.	<ul style="list-style-type: none"> While being operated in CAMERA mode, your camcorder has been in the standby mode for more than 5 minutes. <ul style="list-style-type: none"> → Set the POWER switch to OFF (CHARGE) and then to CAMERA again. (p. 26) The battery pack is dead or nearly dead. <ul style="list-style-type: none"> → Install a fully charged battery pack. (p. 14, 15)
The image on the viewfinder screen is not clear.	<ul style="list-style-type: none"> The viewfinder lens is not adjusted. <ul style="list-style-type: none"> → Adjust the viewfinder lens. (p. 31)
The SteadyShot function does not work. (CCD-TRV78E/TRV98E only)	<ul style="list-style-type: none"> STEADYSHOT is set to OFF in the menu settings. <ul style="list-style-type: none"> → Set it to ON. (p. 69) The SteadyShot function does not work when the wide mode is set to 16:9FULL.
The autofocusing function does not work.	<ul style="list-style-type: none"> FOCUS is set to MANUAL. <ul style="list-style-type: none"> → Set it to AUTO. (p. 55) Shooting conditions are not suitable for autofocus. <ul style="list-style-type: none"> → Set FOCUS to MANUAL to focus manually. (p. 55)
The indicator flashes in the viewfinder.	<ul style="list-style-type: none"> The video heads may be dirty. <ul style="list-style-type: none"> → Clean the heads using the Sony V8-25CLD cleaning cassette (optional). (p. 99)
The picture does not appear in the viewfinder.	<ul style="list-style-type: none"> The LCD panel is open. <ul style="list-style-type: none"> → Close the LCD panel. (p. 28)
A vertical band appears when you shoot a subject such as lights or a candle flame against a dark background.	<ul style="list-style-type: none"> The contrast between the subject and background is too high. This is not a malfunction.
A vertical band appears when you shoot a very bright subject.	<ul style="list-style-type: none"> This is not a malfunction.

(Continued on the following page)

73

Troubleshooting Поиск и устранение неисправностей

Customizing Your Camcorder Выбoreние индивидуальных установок на видеокамере

Types of trouble and their solutions

Symptom	Cause and/or Corrective Actions
An unknown picture is displayed on the screen.	<ul style="list-style-type: none"> If 10 minutes elapse after you set the POWER switch to CAMERA or DEMO MODE is set to ON in the menu settings without a cassette inserted, your camcorder automatically starts the demonstration. <ul style="list-style-type: none"> → Insert a cassette and the demonstration stops. You can also cancel DEMO MODE. (p. 72)
The picture is recorded in incorrect or unnatural colours.	<ul style="list-style-type: none"> NIGHTSHOT is set to ON. <ul style="list-style-type: none"> → Set it to OFF. (p. 34)
The picture appears too bright, and the subject does not appear on the screen.	<ul style="list-style-type: none"> NIGHTSHOT is set to ON in a bright place. <ul style="list-style-type: none"> → Set it to OFF, or use the NightShot function in a dark place. (p. 34) The backlight function is working. <ul style="list-style-type: none"> → Cancel it. (p. 33)

In the playback mode

Symptom	Cause and/or Corrective Actions
The tape does not move when a video control button is pressed.	<ul style="list-style-type: none"> The POWER switch is set to CAMERA or OFF (CHARGE). <ul style="list-style-type: none"> → Set it to PLAYER. (p. 38) The tape has run out. <ul style="list-style-type: none"> → Rewind the tape. (p. 38)
The playback picture is not clear or does not appear.	<ul style="list-style-type: none"> The television's video channel is not adjusted correctly. <ul style="list-style-type: none"> → Adjust it. (p. 42) EDIT is set to ON in the menu settings. <ul style="list-style-type: none"> → Set it to OFF. (p. 70) The video head may be dirty. <ul style="list-style-type: none"> → Clean the heads using the Sony V8-25CLD cleaning cassette (optional). (p. 99)
No sound or only a low sound is heard when playing back a tape.	<ul style="list-style-type: none"> The volume is turned to minimum. <ul style="list-style-type: none"> → Turn up the volume. (p. 38)

Types of trouble and their solutions

In the recording and playback modes

Symptom	Cause and/or Corrective Actions
The power does not turn on.	<ul style="list-style-type: none"> The battery pack is not installed, or is dead or nearly dead. <ul style="list-style-type: none"> → Install a charged battery pack. (p. 14, 15) The AC power adaptor is not connected to the mains. <ul style="list-style-type: none"> → Connect the AC power adaptor to the mains. (p. 20)
The end search function does not work.	<ul style="list-style-type: none"> The tape was ejected after recording. <ul style="list-style-type: none"> → You have not recorded on the new cassette yet.
The battery pack is quickly discharged.	<ul style="list-style-type: none"> The operating temperature is too low. <ul style="list-style-type: none"> → Charge the battery pack fully again. (p. 15) The battery pack is not fully charged. <ul style="list-style-type: none"> → Charge the battery pack fully again. (p. 15) The battery pack is completely dead, and cannot be recharged. <ul style="list-style-type: none"> → Replace with a new battery pack. (p. 14)
The remaining battery time indicator does not indicate the correct time.	<ul style="list-style-type: none"> You have used the battery pack in an extremely hot or cold environment for a long time. <ul style="list-style-type: none"> → Replace with a new battery pack. (p. 14) The battery pack is completely dead, and cannot be recharged. <ul style="list-style-type: none"> → Replace with a new battery pack. (p. 14) The battery is not fully charged. <ul style="list-style-type: none"> → Charge the battery pack fully again. (p. 15) A deviation has occurred in the remaining battery time. <ul style="list-style-type: none"> → Charge the battery pack fully again. (p. 15)
The power goes off although the remaining battery indicator indicates that the battery pack has enough power to operate.	<ul style="list-style-type: none"> A deviation has occurred in the remaining battery time. <ul style="list-style-type: none"> → Charge the battery pack fully again. (p. 15)
The cassette cannot be removed from the holder.	<ul style="list-style-type: none"> The power source is disconnected. <ul style="list-style-type: none"> → Connect it firmly. (p. 14, 20) The battery is dead. <ul style="list-style-type: none"> → Use a charged battery pack. (p. 14, 15)
The and indicators flash and no functions except for cassette ejection work.	<ul style="list-style-type: none"> Moisture condensation has occurred. <ul style="list-style-type: none"> → Remove the cassette and leave your camcorder for at least 1 hour to acclimatize. (p. 98)

(Continued on the following page)

Troubleshooting Поиск и устранение неисправностей

Types of trouble and their solutions

Others

Symptom	Cause and/or Corrective Actions
The Remote Commander supplied with your camcorder does not work. (CCD-TRV49E/TRV59E/TRV78E/TRV98E only)	<ul style="list-style-type: none"> • COMMANDER is set to OFF in the menu settings. <ul style="list-style-type: none"> → Set it to ON. (p. 73) • Something is blocking the infrared rays. <ul style="list-style-type: none"> → Remove the obstacle. • The batteries inserted in the battery holder with the + - polarities incorrectly matching the + - marks. <ul style="list-style-type: none"> → Insert the batteries with the correct polarity. (p. 116) • The batteries are dead. <ul style="list-style-type: none"> → Insert new ones. (p. 116)
The date or time indicator does not appear, and the bars "----" appear.	<ul style="list-style-type: none"> • Reset the date and time. (p. 22)
The melody or beep sounds for 5 seconds.	<ul style="list-style-type: none"> • Moisture condensation has occurred. <ul style="list-style-type: none"> → Remove the cassette and leave your camcorder for at least 1 hour to acclimatize. (p. 98) • Some troubles have occurred in your camcorder. <ul style="list-style-type: none"> → Remove the cassette and insert it again, then operate your camcorder.
No function works though the power is on.	<ul style="list-style-type: none"> • Disconnect the connecting plate of the AC adaptor or remove the battery, then reconnect it in about 1 minute. Turn the power on (p. 14, 20). If the functions still do not work, press the RESET button using a sharp-pointed object. (If you press the RESET button, all the settings including the date and time return to the default.) (p. 112)
While charging the battery pack, the CHG lamp does not light up.	<ul style="list-style-type: none"> • The AC power adaptor is disconnected. <ul style="list-style-type: none"> → Connect it firmly. (p. 15) • Something is wrong with the battery pack. <ul style="list-style-type: none"> → Contact your Sony dealer or local authorized Sony service facility.
You cannot charge the battery pack installed to your camcorder.	<ul style="list-style-type: none"> • The POWER switch is not set to OFF (CHARGE). <ul style="list-style-type: none"> → Set it to OFF (CHARGE).

English

Self-diagnosis display

Your camcorder has a self-diagnosis display function. This function displays the current condition of your camcorder as a 5-digit code (a combination of a letter and figures) on the LCD screen, in the viewfinder or in the display window. If a 5-digit code is displayed, check the following code chart. The last two digits (indicated by □□) will differ depending on the state of your camcorder.

Viewfinder or LCD screen

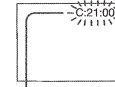

Self-diagnosis display

- C:□□□□
You can service your camcorder yourself.
- E:□□□□
Contact your Sony dealer or local authorized Sony service facility.

Five-digit display	Cause and/or Corrective Actions
C:04:□□	<ul style="list-style-type: none"> • You are using a battery pack that is not an "InfoLITHIUM" battery pack. <ul style="list-style-type: none"> → Use an "InfoLITHIUM" battery pack. (p. 95)
C:21:□□	<ul style="list-style-type: none"> • Moisture condensation has occurred. <ul style="list-style-type: none"> → Remove the cassette and leave your camcorder for at least 1 hour to acclimatize. (p. 98)
C:22:□□	<ul style="list-style-type: none"> • The video heads are dirty. <ul style="list-style-type: none"> → Clean the heads using the Sony V8-25CLD cleaning cassette (optional). (p. 99)
C:31:□□	<ul style="list-style-type: none"> • A malfunction other than the above that you can service has occurred. <ul style="list-style-type: none"> → Remove the cassette and insert it again, then operate your camcorder. → Disconnect the mains lead of the AC power adaptor or remove the battery pack. After reconnecting the power source, operate your camcorder.
C:32:□□	
E:61:□□	<ul style="list-style-type: none"> • A malfunction that you cannot service has occurred. <ul style="list-style-type: none"> → Contact your Sony dealer or local authorized Sony service facility and inform them of the 5-digit code. (example: E:61:10)
E:62:□□	

If you are unable to rectify the problem even if you try corrective actions a few times, contact your Sony dealer or local authorized Sony service facility.

English

Warning indicators and messages

If indicators and messages appear on the screen, check the following: See the page in parentheses "()" for more information.

Warning indicators

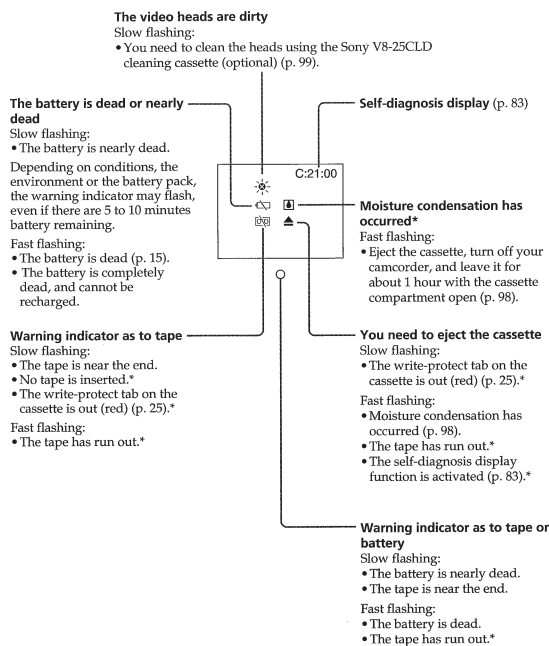

* You hear the melody or beep sound.

Warning indicators and messages

Warning messages

- CLOCK SET Set the date and time (p. 22).
- For "InfoLITHIUM" BATTERY ONLY Use an "InfoLITHIUM" battery pack (p. 95).
- CLEANING CASSETTE The video heads are dirty (p. 99).
- START/STOP KEY Press the START/STOP button to activate the ORC setting. This message is displayed in white. (p. 71).
- ORC The ORC setting is working. This message is displayed in white (p. 71).
- NO TAPE Insert a cassette tape*.
- TAPE END The tape has reached the end of the tape*.

* You hear the melody or beep sound.

Предупреждающие индикаторы и сообщения

Предупреждающие сообщения

• CLOCK SET	Переустановите дату и время (стр. 22).
• For "InfoLITHIUM" BATTERY ONLY	Используйте батарейный блок "InfoLITHIUM" (стр. 95).
• CLEANING CASSETTE	Загрязнились видеоголовки (стр. 99).
• START/STOP KEY	Нажмите кнопку START/STOP для включения установки ORC. Это сообщение высветится белым цветом (стр. 76).
• ORC	Выполняется установка ORC. Это сообщение высветывается белым цветом (стр. 76).
• NO TAPE	Установите кассету с лентой*.
• TAPE END	Достигнут конец ленты*.

* Вы услышите мелодию или зуммерный сигнал.

— Additional Information —

Usable cassettes and playback modes

Selecting the cassette type

You can use both Hi8 and standard 8 mm video cassettes on your camcorder. When you use a Hi8 video cassette, recording and playback are carried out in the Hi8 system. When you use a standard 8 mm video cassette, recording and playback are carried out in the standard 8 mm system.

If you play back a tape recorded on a different video recorder on your camcorder, the playback mode is automatically selected according to the format in which the tape has been recorded.

This Hi8 system is an extension of the standard 8 mm system, and was developed to produce higher quality pictures.

You cannot playback a tape recorded in the Hi8 system correctly on video recorders/players other than a Hi8 video recorder/player.

When you play back

The playback mode (SP/LP) and system, Hi8 or standard 8 mm are automatically selected according to the format in which the tape has been recorded. The quality of the recorded picture in the LP mode, however, will not be as good as the SP mode.

Foreign 8 mm video

Because TV colour systems differ from country to country, you may not be able to play back foreign pre-recorded tapes. Refer to "Using your camcorder abroad" to check the TV colour systems used in foreign countries.

— Дополнительная информация —

Используемые кассеты и режимы воспроизведения

Выбор типа кассеты

Вы можете использовать на Вашей видеокамере либо видеокассеты Hi8, либо стандартные 8-мм видеокассеты. Если Вы используете видеокассету Hi8, запись и воспроизведение будут выполняться в системе Hi8. Если Вы используете стандартную 8-мм видеокассету, запись и воспроизведение будут выполняться в стандартной 8-мм системе. Если Вы будете воспроизводить на Вашей видеокамере ленту, записанную на разных видеомагнитофонах, то режим воспроизведения будет выбираться автоматически в соответствии с форматом, в котором была записана лента.

Система Hi8 является модификацией стандартной 8-мм системы и была разработана для получения высококачественных изображений. Вы не сможете воспроизвести надлежащим образом ленту, записанную в системе Hi8, на видеомагнитофоне/плейере, который не относится к видеомагнитофону/плейеру Hi8.

При выполнении воспроизведения

Режим воспроизведения (SP/LP) и система, Hi8/стандартная 8-мм система выбираются автоматически в соответствии с форматом, в котором была выполнена запись на ленте. Однако, качество записанного изображения в режиме LP не будет таким хорошим, как в режиме SP.

Иностранные 8-мм видеоленты

Поскольку системы цветного телевидения отличаются от страны к стране, возможно Вы не сможете воспроизводить иностранные предварительно записанные ленты. См. раздел "Использование Вашей видеокамеры за границей" для проверки систем цветного телевидения, используемых в других странах.

Usable cassettes and playback modes

Playing back an NTSC-recorded tape

You can play back tapes recorded in the NTSC video system using the SP mode. However, note that the following will occur during playback of an NTSC-recorded tape.

- When playing back a tape on a TV screen, you may not get the original colour depending on the TV. When you play back on a Multi System TV, set NTSC PB to the desired mode in the menu settings.
- During playback, a black band appears on the lower part of the viewfinder.
- You cannot play back a tape recorded in the NTSC video system with the LP mode neither on the LCD nor on a TV screen.
- If a tape has portions recorded in PAL and NTSC video systems, the tape counter reading is not correct. This discrepancy is due to the difference between the counting cycle of the two video systems.
- You cannot edit the NTSC-recorded tape onto another VCR.

Используемые кассеты и режимы воспроизведения

Воспроизведение лент, записанных в системе NTSC

Вы можете воспроизводить ленты, записанные в системе NTSC, используя режим SP.

- Однако, имейте в виду, что во время воспроизведения лент, записанных в системе NTSC, будет иметь место следующее.
- При воспроизведении ленты на экране телевизора Вы можете не получить первоначальные цвета в зависимости от типа телевизора. При воспроизведении на мультисистемном телевизоре установите переключатель NTSC PB на нужный режим в установках меню.
- Во время воспроизведения в нижней части видеодиспетчера будет появляться черная полоса.
- Вы не можете воспроизводить ленту, записанную в видеосистеме NTSC в режиме LP, ни на экране ЖКД, ни на экране телевизора.
- Если на ленте имеются участки, записанные в видеосистемах PAL и NTSC, то функционирование счетчика ленты будет неправильным. Это расхождение объясняется разницей между счетными циклами двух видеосистем.
- Вы не можете выполнять монтаж ленты, записанной в системе NTSC, на другой KBM.

About "InfoLITHIUM" battery

What is the "InfoLITHIUM" battery?

The "InfoLITHIUM" battery is a lithium-ion battery that has functions for communicating information related to operating conditions between your camcorder and an AC power adaptor.

The "InfoLITHIUM" battery calculates the power consumption according to the operating conditions of your camcorder, and displays the remaining battery time in minutes.

Charging the battery

- Be sure to charge the battery before you start using your camcorder.
- We recommend charging the battery in an ambient temperature of between 10 to 30°C until the CHG lamp goes out, indicating that the battery is fully charged. If you charge the battery outside of this temperature range, you may not be able to effectively charge the battery.
- After charging is completed, either disconnect the cable from the DC IN jack on your camcorder or remove the battery.

Effective use of the battery

- Battery performance drops in low-temperature surroundings. So, the time that the battery can be used is shorter in cold places. We recommend the following to ensure care-free, longer use:
 - Put the battery in a pocket close to your body to warm it up, and insert it in your camcorder immediately before you start taking shots.
 - Use the high-power battery (NP-F730/F750/F930/F950/F960, optional).
- Frequently using the LCD screen or frequently operating playback, fast forward or rewind wears out the battery faster. We recommend using the high-power battery (NP-F730/F750/F930/F950/F960, optional).
- Be certain to turn the POWER switch to OFF (CHARGE) while taking shots or playing back on your camcorder. The battery also wears out when your camcorder is in the standby mode or playback is paused.
- Have spare batteries handy for two or three times the expected shooting time, and take test shots before taking the actual shots.

О батарейном блоке "InfoLITHIUM"

Что такое батарейный блок "InfoLITHIUM"?

Батарейный блок "InfoLITHIUM" является литиево-ионным батарейным блоком, который имеет функции для информации связи, относящейся к условиям взаимодействия между Вашей видеокамерой и сетевым адаптером переменного тока. Батарейный блок "InfoLITHIUM" подсчитывает потребляемую мощность в соответствии с условиями эксплуатации Вашей видеокамеры и отображает время оставшегося заряда батарейного блока в минутах.

Зарядка батарейного блока

- Не забудьте зарядить батарейный блок перед началом эксплуатации видеокамеры.
- Мы рекомендуем заряжать батарейный блок при окружающей температуре в пределах между 10 и 30°C до тех пор, пока не погаснет лампочка CHG, означающая, что батарейный блок полностью заряжен. Если Вы будете заряжать батарейный блок вне рекомендуемого температурного диапазона, возможно, Вы не сможете эффективно зарядить батарейный блок.
- После завершения зарядки, либо отсоедините кабель от гнезда DC IN на Вашей видеокамере, либо снимите батарейный блок.

Эффективное использование батарейного блока

- Характеристика батарейного блока упадет при низкой окружающей температуре. Поэтому время использования батарейного блока в холодных местах будет короче. Для обеспечения долговечной эксплуатации без проблем рекомендуется следующее:
 - Положите батарейный блок в свой карман поближе к своему телу для того, чтобы прогреть его, и вставьте его в свою видеокамеру непосредственно перед выполнением съемки.
 - Используйте высокоемкостный батарейный блок (NP-F730/F750/F930/F950/F960, приобретается отдельно).
- Частое использование экрана ЖКД или частое использование функций воспроизведения, ускоренной перемотки вперед или назад приводит к более быстрой разрядке батарейного блока. Рекомендуется использовать высокоемкостный батарейный блок (NP-F730/F750/F930/F950/F960, приобретается отдельно).
- Не забудьте повернуть переключатель POWER в положение OFF (CHARGE) при выполнении съемки или воспроизведения на Вашей видеокамере. Батарейный блок всегда разряжается, если Ваша видеокамера находится в режиме ожидания или паузы воспроизведения.
- Удобно иметь батарейных блоков для времени съемки в два или три раза больше ожидаемого, рекомендует также выполнять пробные съемки перед выполнением реальных съемок.

About "InfoLITHIUM" battery

Remaining battery time indicator

If the POWER switch turns to OFF (CHARGE) immediately even though the remaining battery indicator indicates sufficient battery power, fully charge the battery again. The correct remaining battery time will be indicated. Note, however, that the correct battery indication sometimes will not be restored if it is used in high temperatures for a long time or left in a fully charged state, or the battery is frequently used. Regard the remaining battery time indication as the approximate shooting time.

The CL mark indicating there is little remaining battery time sometimes blinks depending on the operating conditions or ambient temperature and environment even if the remaining battery time is 5 to 10 minutes.

How to store the battery

Even if the battery is not used for a long time, store it in a low humidity, cool place after fully charging it once per year and then using the battery up on your camcorder. This is to maintain the battery's functions.

To use the battery up on your camcorder, leave your camcorder in the shooting mode until there is no more battery power left without a cassette inserted.

Battery life

The battery life is limited. Battery capacity drops little by little as you use it more and more, and as time passes. When the available battery time is shortened considerably, a probable cause is that the battery has reached the end of its life. Buy a new battery.

The battery life varies according to how it is stored and operating conditions and environment for each battery pack.

О батареем блоке "InfoLITHIUM"

Индикатор времени оставшегося заряда батареем блока

Если переключатель POWER будет сразу повернут в положение OFF (CHARGE), даже если индикатор времени оставшегося заряда батареем блока будет указывать достаточный заряд батареем блока, то следует снова полностью зарядить батареем блок. После этого время оставшегося заряда батареем блока будет отображаться правильно. Однако имейте в виду, что правильная индикация времени оставшегося заряда батареем блока иногда не будет восстановлена, если он использовался при высоких температурах длительный период времени или был оставлен в полностью заряженном состоянии, либо же батареем блок часто использовался. Считайте, что индикация времени оставшегося заряда батареем блока означает прилизительное время съемки.

Знак CL , означающий, что осталось немного времени заряда батареем блока, иногда мигает в зависимости от условий эксплуатации или окружающей температуры, даже если время оставшегося заряда батареем блока составляет 5-10 минут.

Как хранить батареем блок

Даже если батареем блок не используется в течение длительного периода времени, храните его при низкой влажности, в прохладном месте после его полной зарядки один раз в год и полного использования заряда на Вашей видеокамере. Это необходимо для поддержания функций батареем блока.

Для полного использования заряда на вашей видеокамере, оставьте вашу видеокамеру в режиме съемки до тех пор, пока заряд батареем блока полностью израсходуется без вставленной кассеты.

Срок службы батареем блока

Срок службы батареем блока ограничен. Емкость батареем блока будет постепенно уменьшаться по мере продолжительности его использования. Если время использования батареем блока существенно уменьшится, вероятной причиной может быть то, что срок службы батареем блока подошел к концу. Купите новый батареем блок.

Срок службы батареем блока зависит от условий хранения и эксплуатации каждого батареем блока.

Using your camcorder abroad

Using your camcorder abroad

You can use your camcorder in any country or area with the AC power adaptor supplied with your camcorder within 100 V to 240 V AC, 50/60 Hz.

Your camcorder is a PAL system based camcorder. If you want to view the playback picture on a TV, it must be a PAL system based TV with VIDEO/AUDIO input jack. The following shows TV colour systems used overseas.

PAL system

Australia, Austria, Belgium, China, Czech Republic, Denmark, Finland, Germany, Great Britain, Holland, Hong Kong, Italy, Kuwait, Malaysia, New Zealand, Norway, Portugal, Singapore, Slovak Republic, Spain, Sweden, Switzerland, Thailand, etc.

PAL-M system

Brazil

PAL-N system

Argentina, Paraguay, Uruguay

NTSC system

Bahama Islands, Bolivia, Canada, Central America, Chile, Colombia, Ecuador, Jamaica, Japan, Korea, Mexico, Peru, Surinam, Taiwan, Philippines, the U.S.A., Venezuela, etc.

SECAM system

Bulgaria, France, Guyana, Hungary, Iran, Iraq, Monaco, Poland, Russia, Ukraine, etc.

Simple setting of clock by time difference

You can easily set the clock to the local time by setting a time difference. Select WORLD TIME in the menu settings. See page 73 for more information.

Использование Вашей видеокамеры за границей

Использование Вашей видеокамеры за границей

Вы можете использовать Вашу видеокамеру в любой стране или области с помощью сетевого адаптера переменного тока, прилагаемого к Вашей видеокамере, который можно использовать в пределах от 100 В до 240 В переменного тока с частотой 50/60 Гц.

Ваша видеокамера основана на системе PAL. Если Вы хотите просмотреть воспроизводимое изображение на телевизоре, то это должен быть телевизор, основанный на системе PAL, с входными гнездами VIDEO/AUDIO. Ниже приведены системы цветного телевидения, используемые за рубежом.

Система PAL

Австралия, Австрия, Бельгия, Великобритания, Германия, Голландия, Гонконг, Дания, Испания, Италия, Китай, Кувейт, Малайзия, Новая Зеландия, Норвегия, Португалия, Сингапур, Словацкая Республика, Таиланд, Финляндия, Чешская Республика, Швейцария, Швеция и т.д.

Система PAL-M

Бразилия

Система PAL-N

Аргентина, Парагвай, Уругвай

Система NTSC

Багамские острова, Боливия, Венесуэла, Канада, Колумбия, Корея, Мексика, Перу, Суринам, США, Тайвань, Филиппины, Центральная Америка, Чили, Эквадор, Ямайка, Япония и т.д.

Система SECAM

Болгария, Венгрия, Гвана, Ирак, Иран, Монако, Польша, Россия, Украина, Франция и т.д.

Простая установка разницы во времени на часах

Вы можете легко установить часы на местное время путем установки разницы во времени. Выберите команду WORLD TIME в установочном меню. Подробные сведения приведены на стр. 78.

Additional Information

Дополнительная информация

Additional Information

Дополнительная информация

96

97

Maintenance information and precautions

Moisture condensation

If your camcorder is brought directly from a cold place to a warm place, moisture may condense inside your camcorder, on the surface of the tape, or on the lens. In this condition, the tape may stick to the head drum and be damaged or your camcorder may not operate correctly. If there is moisture inside your camcorder, the beep sounds and the CL indicator flashes. When the CL indicator flashes at the same time, the cassette is inserted in your camcorder. If moisture condenses on the lens, the indicator will not appear.

If moisture condensation occurs

None of the functions except cassette ejection will work. Eject the cassette, turn off your camcorder, and leave it for about 1 hour with the cassette compartment open. Your camcorder can be used again if the CL indicator does not appear when the power is turned on again.

Note on moisture condensation

Moisture may condense when you bring your camcorder from a cold place into a warm place (or vice versa) or when you use your camcorder in a hot place as follows:

- You bring your camcorder from a ski slope into a place warmed up by a heating device
- You bring your camcorder from an air-conditioned car or room into a hot place outside
- You use your camcorder after a squall or a shower
- You use your camcorder in a high temperature and humid place

How to prevent moisture condensation

When you bring your camcorder from a cold place into a warm place, put your camcorder in a plastic bag and tightly seal it. Remove the bag when the air temperature inside the plastic bag has reached the surrounding temperature (after about 1 hour).

Информация по уходу за аппаратом и меры предосторожности

Конденсация влаги

Если видеокамера принесена прямо из холодного места в теплое, то внутри видеокамеры, на поверхности ленты или на объективе может произойти конденсация влаги. В таком состоянии лента может прилипнуть к барабану головки и будет повреждена или же видеокамера не сможет работать надлежащим образом. Если внутри видеокамеры произошла конденсация влаги, то прозвучит зуммерный сигнал и будет мигать индикатор CL . Если в то же самое время будет мигать индикатор CL , это значит, что в видеокамеру вставлена кассета. Если влага сконденсировалась на объективе, индикатор появляться не будет.

Если произойдет конденсация влаги

Ни одна из функций, кроме выталкивания кассеты, не будет работать. Извлеките кассету, выключите видеокамеру и оставьте ее приблизительно на 1 час с открытым отсеком для кассеты. Если при повторном включении питания индикатор CL не появится на дисплее, Вы можете снова пользоваться видеокамерой.

Примечание по конденсации влаги

Влага может образоваться, если Вы принесете Вашу видеокамеру из холодного места в теплое (или наоборот) или когда Вы используете Вашу видеокамеру в жарком месте в следующих случаях:

- Вы принесли Вашу видеокамеру с лыжного склона в помещение, где функционирует обогреватель
- Вы принесли Вашу видеокамеру из автомобиля или из комнаты с воздушным кондиционированием в жаркое место на улице
- Вы используете видеокамеру после грозы или дождя
- Вы используете Вашу видеокамеру в очень жарком и влажном месте

Как предотвратить конденсацию влаги

Если видеокамера принесена из холодного места в теплое, то положите видеокамеру в полиэтиленовый пакет и плотно закройте его. Выньте видеокамеру из полиэтиленового пакета, когда температура воздуха внутри пакета достигнет температуры окружающего воздуха (приблизительно через 1 час).

Maintenance information and precautions

Maintenance information

Cleaning the video head

To ensure normal recording and clear pictures, clean the video heads. The video head may be dirty when:

- The CL indicator and "CLEANING CASSETTE" message appear one after another or the CL indicator flashes on the screen.
- Playback pictures contain noise.
- Playback pictures are hardly visible.
- Playback pictures do not appear.

If this happens, clean the video heads with the Sony V8-25CLD cleaning cassette (optional).



[a] Slightly dirty

[b] Very dirty

Note on video heads

When the playback pictures still contain noise even if you have cleaned the video heads with a cleaning cassette, the video heads may have worn down due to long use. If this is the case, they must be replaced with new heads. Contact your Sony dealer or local authorized Sony service facility.

Информация по уходу за аппаратом и меры предосторожности

Информация по уходу за аппаратом

Чистка видеоголовки

Для обеспечения нормальной записи и четкого изображения следует периодически чистить видеоголовки. Видеоголовки возможно загрязнены, если:

- На экране появляются один за другим индикатор CL и сообщение "CLEANING CASSETTE" или же мигает индикатор CL .
- Воспроизводимое изображение содержит помехи.
- Воспроизводимое изображение с трудом различимо.
- Воспроизводимое изображение не появляется на экране.

Если это произошло, почистите видеоголовки с помощью очистительной кассеты Sony V8-25CLD (приобретается отдельно).

Примечание по видеоголовкам

Если воспроизводимое изображение все еще содержит помехи даже после того, как Вы почистили видеоголовки с помощью очистительной кассеты, то, возможно, видеоголовки уже износились вследствие длительной эксплуатации видеокамеры. В этом случае, их следует заменить на новые. Обратитесь в сервисный центр Sony или в местное уполномоченное предприятие по обслуживанию изделий Sony.

98

99

Maintenance information and precautions

About care and storage of the lens

- Wipe the surface of the lens clean with a soft cloth in the following instances.
 - When there are fingerprints on the lens surface
 - In hot or humid locations
 - When the lens is used in environments susceptible to salt such as the seaside
- Store the lens in a well-ventilated location subject to little dirt or dust.

To prevent mold from occurring, periodically perform the above.
We recommend turning on and operating your camcorder about once per month to keep your camcorder in an optimum state for a long time.

Cleaning the LCD screen

If fingerprints or dust make the LCD screen dirty, we recommend using a LCD Cleaning Kit (optional) to clean the LCD screen.

Removing dust from inside the viewfinder

- (1) Remove the screw with a screwdriver (not supplied). (2) Then, while holding the RELEASE knob up, (3) turn the eyecup in a counterclockwise direction and pull it out.
- (2) Clean the surface with a commercially available blower for a still camera.
- (3) Turn the eyecup in a clockwise direction, then replace the screw.

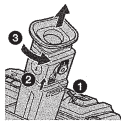

Caution

Do not remove any other screws. You may remove only the screw to remove the eyecup.

Информация по уходу за аппаратом и меры предосторожности

Об уходе за объективом и его хранении

- В следующих случаях следует протирать поверхность объектива джиста:
 - Если на поверхности объектива имеются отпечатки
 - В жарких и влажных местах
 - Если объектив используется в условиях, подверженных воздействию соли, например, на морском курорте.
- Храните объектив в хорошо проветриваемом месте без излишней грязи и пыли.

Для предотвращения образования плесени, периодически выполняйте приведенные выше процедуры.

Рекомендуется включать и использовать некоторое время Вашу видеокамеру один раз в месяц для поддержания оптимального состояния Вашей видеокамеры в течение длительного времени.

Чистка экрана ЖКД

Если на экране ЖКД появляются отпечатки или пыль, рекомендуется воспользоваться очистительным набором для ЖКД (не прилагается) для чистки ЖКД.

Удаление пыли изнутри видеоискателя

- (1) Отвинтите винт с помощью отвертки (по заказу). (2) Затем, передвинув кнопку RELEASE, (3) поверните окуляр в направлении против часовой стрелки и потяните его.
- (2) Почистите поверхность с помощью воздушной струи для фотоаппаратов, которая приобретается отдельно.
- (3) Прикрепите окуляр в направлении по часовой стрелке и закрутите винт обратно на место.

Внимание

Не отвинчивайте другие винты. Вы можете отвинчивать только винт для снятия окуляра.

Maintenance information and precautions

Charging the built-in rechargeable lithium cell

Your camcorder is supplied with a built-in rechargeable lithium cell so as to retain the date and time, etc., regardless of the setting of the POWER switch. The rechargeable lithium cell is always charged as long as you are using your camcorder. The cell, however, will get discharged gradually if you do not use your camcorder. It will be completely discharged in about 4 months if you do not use your camcorder at all. Even if the rechargeable lithium cell is not charged, it will not affect the camcorder operation. To retain the date and time, etc., charge the cell if the cell is discharged.

Charging the rechargeable lithium cell:

- Connect your camcorder to the mains using the AC power adaptor supplied with your camcorder, and leave your camcorder with the POWER switch turned off for more than 24 hours.
- Or install the fully charged battery pack in your camcorder with the POWER switch turned off for more than 24 hours.

Информация по уходу за аппаратом и меры предосторожности

Зарядка встроенного перезаряжаемого литиевого элемента

Ваша видеокамера оснащена перезаряжаемой литиевой батареей, установленной для того, чтобы поддерживать дату, время и т.д., вне зависимости от установки переключателя POWER. Перезаряжаемая литиевая батарея всегда заряжена, когда Вы используете Вашу видеокамеру. Однако, батарея постепенно разрядится, если Вы не будете использовать Вашу видеокамеру. Она будет полностью разряжена примерно через 4 месяца, если Вы вообще не будете пользоваться Вашей видеокамерой. Даже если перезаряжаемая литиевая батарея не заряжена, она не повлияет на работу видеокамеры. Чтобы поддерживать дату и время, зарядите батарею, если она разрядилась.

Зарядка перезаряжаемого литиевого элемента:

- Подсоедините Вашу видеокамеру к электросети с помощью светового адаптера переменного тока, прилагаемого к Вашей видеокамере, и оставьте Вашу видеокамеру при выключенном положении переключателя POWER более чем на 24 часа.
- Или прикрепите полностью заряженный батарейный блок к Вашей видеокамере и оставьте Вашу видеокамеру с выключенным переключателем POWER более чем на 24 часа.

Additional Information
Дополнительная информация

Maintenance information and precautions

Precautions

Camcorder operation

- Operate your camcorder on 7.2 V (battery pack) or 8.4 V (AC power adaptor).
- For DC or AC operation, use the accessories recommended in this operating instructions.
- If any solid object or liquid get inside the casing, unplug your camcorder and have it checked by a Sony dealer before operating it any further.
- Avoid rough handling or mechanical shock. Be particularly careful of the lens.
- Keep the POWER switch set to OFF (CHARGE) when you are not using your camcorder.
- Do not wrap your camcorder with a towel, for example, and operate it. Doing so might cause heat to build up inside.
- Keep your camcorder away from strong magnetic fields or mechanical vibration.
- Do not touch the LCD screen with your fingers or a sharp-pointed object.
- If your camcorder is used in a cold place, a residual image may appear on the LCD screen. This is not a malfunction.
- While using your camcorder, the back of the LCD screen may heat up. This is not a malfunction.

Информация по уходу за аппаратом и меры предосторожности

Меры предосторожности

Эксплуатация видеокамеры

- Эксплуатируйте видеокамеру от 7,2 В (батарейный блок) или 8,4 В (сетевой адаптер переменного тока).
- Что касается эксплуатации видеокамеры от постоянного и переменного тока, используйте принадлежности, рекомендуемые в данной инструкции по эксплуатации.
- Если какой-нибудь твердый предмет или жидкость попали внутрь корпуса, то выключите видеокамеру и проверьте ее у дилера Sony перед дальнейшей ее эксплуатацией.
- Избегайте грубого обращения с видеокамерой или механических ударов.
- Будьте особенно осторожны с объективом.
- Если видеокамера не используется, держите выключатель POWER в положении OFF (CHARGE).
- Не заворачивайте Вашу видеокамеру, например, в полотенце, и не эксплуатируйте ее в таком состоянии. В противном случае может произойти повышение температуры внутри видеокамеры.
- Держите Вашу видеокамеру подальше от сильных магнитных полей или механической вибрации.
- Не прикасайтесь к экрану ЖКД своими пальцами или острыми предметами.
- При эксплуатации Вашей видеокамеры в холодном месте, на экране ЖКД может появляться остаточное изображение. Это не является неисправностью.
- При эксплуатации Вашей видеокамеры, задняя сторона экрана ЖКД может нагреваться. Это не является неисправностью.

Maintenance information and precautions

Built-in light

- Do not knock or jolt the built-in light while it is turned on as it may damage the bulb or shorten the life of the bulb.
- Do not leave the built-in light on while it is resting on or against something; it may cause a fire or damage the built-in light.

On handling tapes

Do not insert anything into the small holes on the rear of the cassette. These holes are used to sense the type and thickness of the tape and if the recording tab is in or out.

Camcorder care

- Remove the tape, and periodically turn on the power, and operate the CAMERA and PLAYER sections and play back a tape for about 5 minutes when your camcorder is not to be used for a long time.
- Clean the lens with a soft brush to remove dust. If there are fingerprints on the lens, remove them with a soft cloth.
- Clean the camcorder body with a dry soft cloth, or a soft cloth lightly moistened with a mild detergent solution. Do not use any type of solvent which may damage the finish.
- Do not let sand get into your camcorder. When you use your camcorder on a sandy beach or in a dusty place, protect it from the sand or dust. Sand or dust may cause your camcorder to malfunction, and sometimes this malfunction cannot be repaired.

Информация по уходу за аппаратом и меры предосторожности

Встроенная подсветка

- Не стучите по устройству подсветки и не трясите его в то время, когда оно включено, поскольку это может повредить лампу накаливания или сократить ее срок службы.
- Не оставляйте встроенную подсветку включенной в то время, когда она на чем-то лежит или направлена на какой-либо предмет.

Относительно обращения с лентами

Не вставляйте ничего в маленькие отверстия на задней стороне кассеты. Эти отверстия используются для определения типа и толщины ленты, а также для определения наличия или отсутствия лепестка защиты записи на ленте.

Уход за видеокамерой

- Если Ваша видеокамера не будет использоваться в течение длительного времени, выньте кассету с лентой и периодически включайте питание, оперируйте устройствами CAMERA и PLAYER и воспроизведите ленту в течение 5-ти минут.
- Чистите объектив с помощью мягкой кисточки для удаления пыли. Если имеются отпечатки пальцев на объективе, удалите их с помощью мягкой ткани.
- Чистите корпус видеокамеры с помощью сухой мягкой ткани или мягкой ткани, слегка смоченной раствором умеренного мощного средства. Не используйте каких-либо типов растворителей, которые могут повредить отделку.
- Не допускайте попадания песка в видеокамеру. Если Вы используете видеокамеру на песчаном пляже или в каком-либо пыльном месте, предохраните аппарат от песка или пыли. Песок или пыль могут привести к неисправности аппарата, которая иногда может быть неисправимой.

Additional Information
Дополнительная информация

Maintenance information and precautions

AC power adaptor

- Unplug the unit from the mains when you are not using the unit for a long time. To disconnect the mains lead, pull it out by the plug. Never pull the mains lead itself.
- Do not operate the unit with a damaged cord or if the unit has been dropped or damaged.
- Do not bend the mains lead forcibly, or place a heavy object on it. This will damage the cord and may cause fire or electrical shock.
- Prevent metallic objects from coming into contact with the metal parts of the connecting section. If this happens, a short may occur and the unit may be damaged.
- Always keep metal contacts clean.
- Do not disassemble the unit.
- Do not apply mechanical shock or drop the unit.
- While the unit is in use, particularly during charging, keep it away from AM receivers and video equipment. AM receivers and video equipment disturb AM reception and video operation.
- The unit becomes warm during use. This is not a malfunction.
- Do not place the unit in locations that are:
 - Extremely hot or cold
 - Dusty or dirty
 - Very humid
 - Vibrating

Информация по уходу за аппаратом и меры предосторожности

Сетевой адаптер переменного тока

- Отсоедините аппарат от электрической сети, если он не используется длительное время. Для отсоединения сетевого шнура потяните его за разъем. Никогда не тяните за сам шнур.
- Не эксплуатируйте аппарат с поврежденным шнуром или же в случае, если аппарат упал или был поврежден.
- Не сгибайте сетевой провод силой и не ставьте на него тяжелые предметы. Это повредит провод и может привести к пожару или поражению электрическим током.
- Будьте осторожны, чтобы никакие металлические предметы не соприкасались с металлическими частями соединительной секции. Если это случится, то может произойти короткое замыкание, и аппарат может быть поврежден.
- Всегда поддерживайте металлические контакты в чистоте.
- Не разбирайте аппарат.
- Не подвергайте аппарат механической вибрации и не роняйте его.
- При использовании аппарата, особенно во время зарядки, держите его подальше от приемников AM-радиовещания и видеоаппаратуры. Приемники AM-радиовещания и видеоаппаратура нарушают AM-радиоприем и работу видеоаппаратуры.
- В процессе эксплуатации аппарат нагревается. Это является вполне нормальным.
- Не размещайте аппарат в местах:
 - Чрезмерно жарких или холодных
 - Пыльных или грязных
 - Очень влажных
 - Подверженных вибрации

Maintenance information and precautions

Battery pack

- Use only the specified charger or video equipment with the charging function.
- To prevent an accidental short circuit, do not allow metal objects to come into contact with the battery terminals.
- Keep the battery pack away from fire.
- Never expose the battery pack to temperatures above 60°C (140°F), such as in a car parked in the sun or under direct sunlight.
- Keep the battery pack dry.
- Do not expose the battery pack to any mechanical shock.
- Do not disassemble nor modify the battery pack.
- Attach the battery pack to the video equipment securely.
- Charging while some capacity remains does not affect the original battery capacity.

Notes on dry batteries

– CCD-TRV49E/TRV59E/TRV78E/TRV98E only

To avoid possible damage from battery leakage or corrosion, observe the following:

- Be sure to insert the batteries with the + – polarities matched to the + – marks.
- Dry batteries are not rechargeable.
- Do not use a combination of new and old batteries.
- Do not use different types of batteries.
- Current flows from batteries when you are not using them for a long time.
- Do not use leaking batteries.

If batteries are leaking

- Wipe off the liquid in the battery compartment carefully before replacing the batteries.
- If you touch the liquid, wash it off with water.
- If the liquid get into your eyes, wash your eyes with a lot of water and then consult a doctor.

If any problem occurs, unplug your camcorder and contact your nearest Sony dealer.

Информация по уходу за аппаратом и меры предосторожности

Батарейный блок

- Используйте только указанные устройством зарядки или видеоаппаратуру с функцией зарядки.
- Для предотвращения несчастного случая из-за короткого замыкания не допускайте контакта металлических предметов с контактами батарейного блока.
- Храните батарейный блок подальше от огня.
- Никогда не подвергайте батарейный блок воздействию температур выше 60°C, например, не оставляйте батарейный блок в припаркованном автомобиле под солнцем или прямым солнечным светом.
- Храните батарейный блок в сухом виде.
- Не подвергайте батарейный блок механическим ударам.
- Не разбирайте и не передельвайте батарейный блок.
- Подсоединяйте батарейный блок к видеоаппаратуру плотно.
- Зарядка при наличии оставшейся емкости не влияет на первоначальную емкость батарейного блока.

Примечание к сухим батарейкам

– Только модели CCD-TRV76E/TRV78E/TRV98E

- Во избежание возможного повреждения видеокамеры вследствие утечки внутреннего вещества батареек или коррозии соблюдайте следующее:
 - При установке батареек соблюдайте правильную полярность + – в соответствии с метками + –.
 - Сухие батарейки нельзя перезаряжать.
 - Не используйте новые батарейки вместе со старыми.
 - Не используйте батарейки разного типа.
 - Если батарейки не используются длительное время, они постепенно разряжаются.
 - Не используйте батарейки, которые потекли.
- Если произошла утечка внутреннего вещества батареек
 - Перед тем, как заменить батарейки, тщательно протрите остатки жидкости в отсеке для батареек.
 - В случае попадания жидкости на кожу, промойте жидкость водой.
 - В случае попадания жидкости в глаза, промойте свои глаза большим количеством воды, после чего обратитесь к врачу.

В случае возникновения каких-либо проблем, отключите Вашу видеокамеру от источника питания и обратитесь в ближайший сервисный центр Sony.

Additional Information
Дополнительная информация

104

— Quick Reference —

Identifying the parts and controls

Camcorder

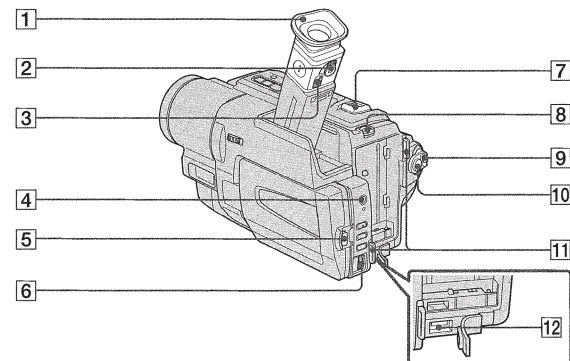

- 1 Eyecup (p. 100)
- 2 Viewfinder lens adjustment lever (p. 31)
- 3 Eyecup RELEASE knob (p. 100)
- 4 (earphone) jack
When you use earphone, the speaker on your camcorder is silent.
- 5 OPEN button (p. 26)
- 6 SEL/PUSH EXEC dial (p. 45, 67)
- 7 Power zoom lever (p. 30)
- 8 BATT RELEASE lever (p. 14)
- 9 POWER switch (p. 26)
- 10 START/STOP button (p. 26)
- 11 Hooks for shoulder strap (p. 112)
- 12 DC IN jack (p. 15, 20)

— Оперативный справочник —

Обозначение частей и регуляторов

Видеокамера

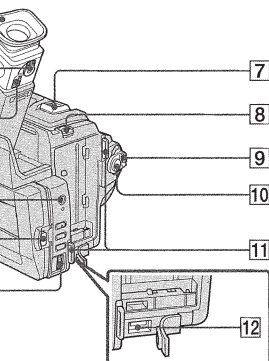

- 1 Окуляр (стр. 100)
- 2 Рычаг регулировки объектива видискателя (стр. 31)
- 3 Кнопка окуляра RELEASE (стр. 100)
- 4 Гнездо (earphone) (наушники)
Если Вы используете гнездо (наушники), динамик на Вашей видеокамере отключается.
- 5 Кнопка OPEN (стр. 26)
- 6 Дискк SEL/PUSH EXEC (стр. 45, 67)
- 7 Рычаг приводного вариообъектива (стр. 30)
- 8 Рычаг BATT RELEASE (стр. 14)
- 9 Переключатель POWER (стр. 26)
- 10 Кнопка START/STOP (стр. 26)
- 11 Крючок для плечевого ремня (стр. 112)
- 12 Гнездо DC IN (стр. 15, 20)

Identifying the parts and controls

Обозначение частей и регуляторов

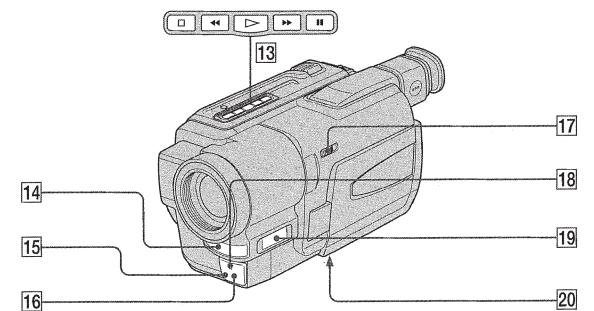

- 13 Video control buttons (p. 38, 40)
 - STOP (stop)
 - ◀ REW (rewind)
 - ▶ PLAY (playback)
 - ▶▶ FF (fastforward)
 - || PAUSE (pause)
- 14 Microphone
- 15 Remote sensor (CCD-TRV49E/TRV59E/TRV78E/TRV98E only) (p. 116)
- 16 Infrared rays emitter (p. 34)
- 17 NIGHTSHOT switch (p. 34)
- 18 Camera recording lamp (p. 26)
- 19 Display window (p. 118)
- 20 Tripod receptacle (base)
Make sure that the length of the tripod screw is less than 6.5 mm (9/32 inch). Otherwise, you cannot attach the tripod securely and the screw may damage your camcorder.

- 13 Кнопки видеоконтроля (стр. 38, 40)
 - STOP (остановка)
 - ◀◀ REW (ускоренная перемотка назад)
 - ▶▶ PLAY (воспроизведение)
 - ▶▶▶ FF (ускоренная перемотка вперед)
 - || PAUSE (пауза)
- 14 Микрофон
- 15 Датчик дистанционного управления (Только модели CCD-TRV49E/TRV59E/TRV78E/TRV98E) (стр. 116)
- 16 Излучатель инфракрасных лучей (стр. 34)
- 17 Переключатель NIGHTSHOT (стр. 34)
- 18 Лампочка записи видеокамеры (стр. 26)
- 19 Окошко дисплея (стр. 118)
- 20 Гнездо для треноги (основание)
Убедитесь, что длина винта треноги менее 6,5 мм. В противном случае Вы не сможете надежно прикрепить треногу, а винт может повредить Вашу видеокамеру.

Quick Reference
Оперативный справочник

105

This mark indicates that this product is a genuine accessory for Sony video products. When purchasing Sony video products, Sony recommends that you purchase accessories with this "GENUINE VIDEO ACCESSORIES" mark.

Данный знак означает, что это изделие является подлинной принадлежностью для видеоаппаратуры Sony. При покупке видеоаппаратуры Sony рекомендуется приобретать для нее принадлежности Sony с таким знаком "GENUINE VIDEO ACCESSORIES".

110

111

Identifying the parts and controls

Обозначение частей и регуляторов

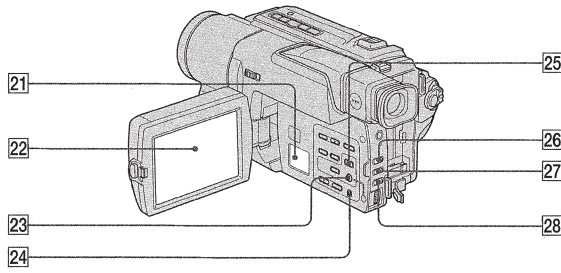

- 21 Speaker
- 22 LCD screen (p. 28)
- 23 MENU button (p. 67)
- 24 RESET button (p.82)
- 25 EXPOSURE button (p. 54)
- 26 FADER button (p. 47)
- 27 BACK LIGHT button (p. 33)
- 28 FOCUS button (p. 55)

- 21 Динамик
- 22 Экран ЖКД (стр. 28)
- 23 Кнопка MENU (стр. 67)
- 24 Кнопка RESET (стр. 89)
- 25 Кнопка EXPOSURE (стр. 54)
- 26 Кнопка FADER (стр. 47)
- 27 Кнопка BACK LIGHT (стр. 33)
- 28 Переключатель FOCUS (стр. 55)

Attaching the shoulder strap
 Attach the shoulder strap supplied with your camcorder to the hooks for the shoulder strap.

Прикрепление плечевого ремня
 Прикрепите плечевой ремень, прилагаемый к Вашей видеокамере, к крючкам для плечевого ремня.



Identifying the parts and controls

Обозначение частей и регуляторов

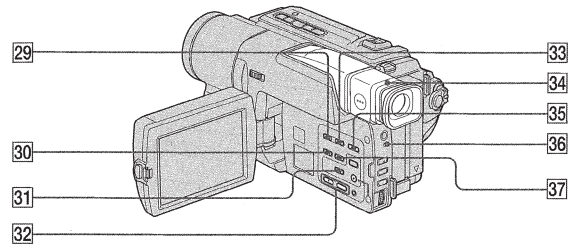

- 29 DATE button (p. 36)
- 30 DISPLAY button (p. 39)
- 31 TITLE button (p. 57)
- 32 VOLUME buttons (p. 38)
- 33 TIME button (p. 36)
- 34 Viewfinder (p. 31)
- 35 COUNTER RESET button (p. 27)
- 36 CHG lamp (p. 15)
- 37 END SEARCH button (p. 37)

- 29 Кнопка DATE (стр. 36)
- 30 Кнопка DISPLAY (стр. 39)
- 31 Кнопка TITLE (стр. 57)
- 32 Кнопка VOLUME (стр. 38)
- 33 Кнопка TIME (стр. 36)
- 34 Видоискатель (стр. 31)
- 35 Кнопка COUNTER RESET (стр. 27)
- 36 Лампа CHG (стр. 15)
- 37 Кнопка END SEARCH (стр. 37)

Attaching the lens cap
 Attach the lens cap to the grip strap as illustrated.

Прикрепление крышечки объектива
 Прикрепление крышечки объектива к ремню для захвата, как показано на рисунке.

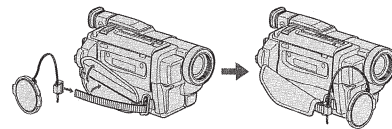

Identifying the parts and controls

Обозначение частей и регуляторов

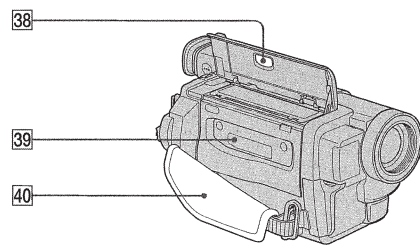

- 38 EJECT button (p. 22)
- 39 Cassette compartment (p. 22)
- 40 Grip strap

- 38 Кнопка EJECT (стр. 22)
- 39 Кассетный отсек (стр. 22)
- 40 Ремень для захвата

Fastening the grip strap

Прикрепление ремня для захвата

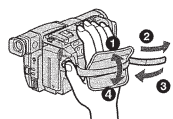

Fasten the grip strap firmly.

Прикрепите ремень для захвата надежно.

Identifying the parts and controls

Обозначение частей и регуляторов

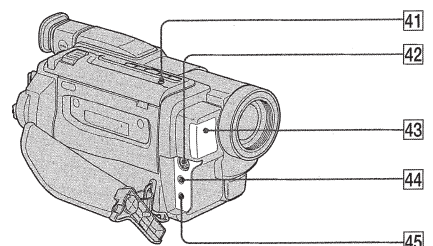

- 41 LIGHT button (p. 61)
- 42 S VIDEO OUT jack (p. 42)
- 43 Built-in light (p. 61)
- 44 A/V OUT jack (p. 42)
- 45 RFU DC OUT (RFU adaptor DC output) jack (p. 43)

- 41 Кнопка LIGHT (стр. 61)
- 42 Гнездо S VIDEO OUT (стр. 42)
- 43 Встроенная подсветка (стр. 61)
- 44 Гнездо A/V OUT (стр. 42)
- 45 Гнездо RFU DC OUT (выход пост. тока ВЧ-адаптера) (стр. 43)

Identifying the parts and controls

Remote Commander

– CCD-TRV49E/TRV59E/TRV78E/TRV98E only
The buttons that have the same name on the Remote Commander as on your camcorder function identically to the buttons on your camcorder.

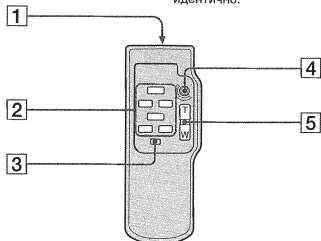

- 1 **Transmitter**
Point toward the remote sensor to control your camcorder after turning on your camcorder.
- 2 **Video control buttons** (p. 40)
- 3 **DISPLAY button** (p. 39)
- 4 **START/STOP button** (p. 26)
- 5 **Power zoom button** (p. 30)

To prepare the Remote Commander
Insert 2 R6 (size AA) batteries by matching the + and – polarities on the batteries to the + – marks inside the battery compartment.

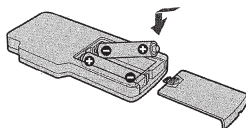

Обозначение частей и регуляторов

Пульт дистанционного управления

– Только модели CCD-TRV49E/TRV59E/TRV78E/TRV98E
Кнопки пульта дистанционного управления, которые имеют одинаковые наименования с кнопками на видеокамере, функционируют идентично.

- 1 **Передатчик**
Направьте на дистанционный датчик для управления Вашей видеокамерой после ее включения.
- 2 **Кнопки видеоконтроля** (стр. 40)
- 3 **Кнопка DISPLAY** (стр. 39)
- 4 **Кнопка START/STOP** (стр. 26)
- 5 **Кнопка приводного вариообъектива** (стр. 30)

Для подготовки пульта дистанционного управления
Вставьте 2 батарейки R6 (размера AA), соблюдая надлежащую полярность + и – на батарейках в соответствии со знаками + – внутри отсека для батареек.

Identifying the parts and controls

Notes on the Remote Commander

- Point the remote sensor away from strong light sources such as direct sunlight or overhead lighting. Otherwise, the Remote Commander may not function properly.
- Your camcorder works in the commander mode VTR 2. Commander modes 1, 2 and 3 are used to distinguish your camcorder from other Sony VCRs to avoid remote control misoperation. If you use another Sony VCR in the commander mode VTR 2, we recommend changing the commander mode or covering the sensor of the VCR with black paper.

Обозначение частей и регуляторов

Примечания к пульту дистанционного управления

- Держите дистанционный датчик подальше от сильных источников света, как например, прямые солнечные лучи или иллюминация. В противном случае дистанционное управление может не действовать.
- Данная видеокамера работает в режиме пульта дистанционного управления VTR 2. Режимы пульта дистанционного управления 1, 2 и 3 используются для отличия данной видеокамеры от других КВМ фирмы Sony во избежание неправильной работы дистанционного управления. Если Вы используете другой КВМ фирмы Sony, работающий в режиме VTR 2, мы рекомендуем Вам изменить режим пульта дистанционного управления или закрыть дистанционный датчик КВМ черной бумагой.

116

117

Quick Reference
Оперативный справочник

Identifying the parts and controls

Operation indicators

LCD screen and Viewfinder/
Экран ЖКД и видоискатель

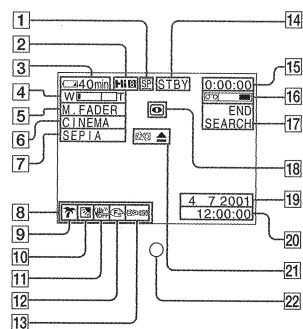

- 1 **Recording mode indicator** (p. 71)/Mirror mode indicator (p. 28)
- 2 **H18 format indicator**
- 3 **Remaining battery time indicator** (p. 32)
- 4 **Exposure indicator** (p. 54)/Zoom indicator (p. 30)
- 5 **Fader indicator** (p. 47)
- 6 **Wide mode indicator** (p. 44)
- 7 **Picture effect indicator** (p. 50)
- 8 **Volume indicator** (p. 38)
- 9 **PROGRAM AE indicator** (p. 51)
- 10 **Backlight indicator** (p. 33)
- 11 **SteadyShot off indicator** (CCD-TRV78E/TRV98E only) (p. 70)
- 12 **Manual focusing indicator** (p. 55)
- 13 **Built-in light indicator** (p. 61)

Обозначение частей и регуляторов

Рабочие индикаторы

Display window/Окошко дисплея

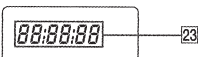

- 1 **Индикатор режима записи** (стр. 76)/индикатор зеркального режима (стр. 28)
- 2 **Индикатор формата H18**
- 3 **Индикатор оставшегося заряда батарейного блока** (стр. 32)
- 4 **Индикатор экспозиции** (стр. 54)/индикатор вариообъектива (стр. 30)
- 5 **Индикатор фейдера** (стр. 47)
- 6 **Индикатор широкоформатного режима** (стр. 44)
- 7 **Индикатор эффекта изображения** (стр. 50)
- 8 **индикатор громкости** (стр. 38)
- 9 **Индикатор PROGRAM AE** (стр. 51)
- 10 **Индикатор задней подсветки** (стр. 33)
- 11 **Индикатор выключенной устойчивой съемки (CCD-TRV78E/TRV98E)** (стр. 75)
- 12 **Индикатор ручной фокусировки** (стр. 55)
- 13 **Индикатор встроенной подсветки** (стр. 61)

Identifying the parts and controls

- 14 **STBY/REC indicator** (p. 26)/Video control mode indicator (p. 40)
- 15 **Tape counter indicator** (p. 32)/Self-diagnosis display indicator (p. 83)
- 16 **Remaining tape indicator** (p. 32)
- 17 **END SEARCH indicator** (p. 37)
- 18 **NIGHTSHOT indicator** (p. 34)
- 19 **AUTO DATE indicator** (p. 23)/Date indicator (p. 23, 36)
- 20 **Time indicator** (p. 23, 36)
- 21 **Warning indicators** (p. 84)
- 22 **Recording lamp** (p. 26)
This indicator appears in the viewfinder only
- 23 **Date or time indicator** (p. 23, 36)/Tape counter indicator (p. 32)/Self-diagnosis display indicator (p. 83)

Обозначение частей и регуляторов

- 14 **Индикатор STBY/REC** (стр. 26)/индикатор режима видеоконтроля (стр. 40)
- 15 **Индикатор счетчика ленты** (стр. 32)/индикатор функции самодиагностики (стр. 90)
- 16 **Индикатор оставшейся ленты** (стр. 32)
- 17 **Индикатор END SEARCH** (стр. 37)
- 18 **Индикатор NIGHTSHOT** (стр. 34)
- 19 **Индикатор AUTO DATE** (стр. 23)/индикатор даты (стр. 23, 36)
- 20 **Индикатор времени** (стр. 23, 36)
- 21 **Предупреждающие индикаторы** (стр. 91)
- 22 **Лампочка записи** (стр. 26)
Индикатор появляется только в окне видоискателя
- 23 **Индикатор даты или времени** (стр. 23, 36)/индикатор счетчика ленты (стр. 32)/индикатор функции самодиагностики (стр. 90)

118

119

Quick Reference
Оперативный справочник

CCD-TR618/TR618E/TR718E/TR728E/TR818/TRV49/TRV49E/TRV58/ TRV58E/TRV59E/TRV68/TRV78/TRV78E/TRV88/TRV98/TRV98E

SECTION 2 DISASSEMBLY

The following flow chart shows the disassembly procedure.

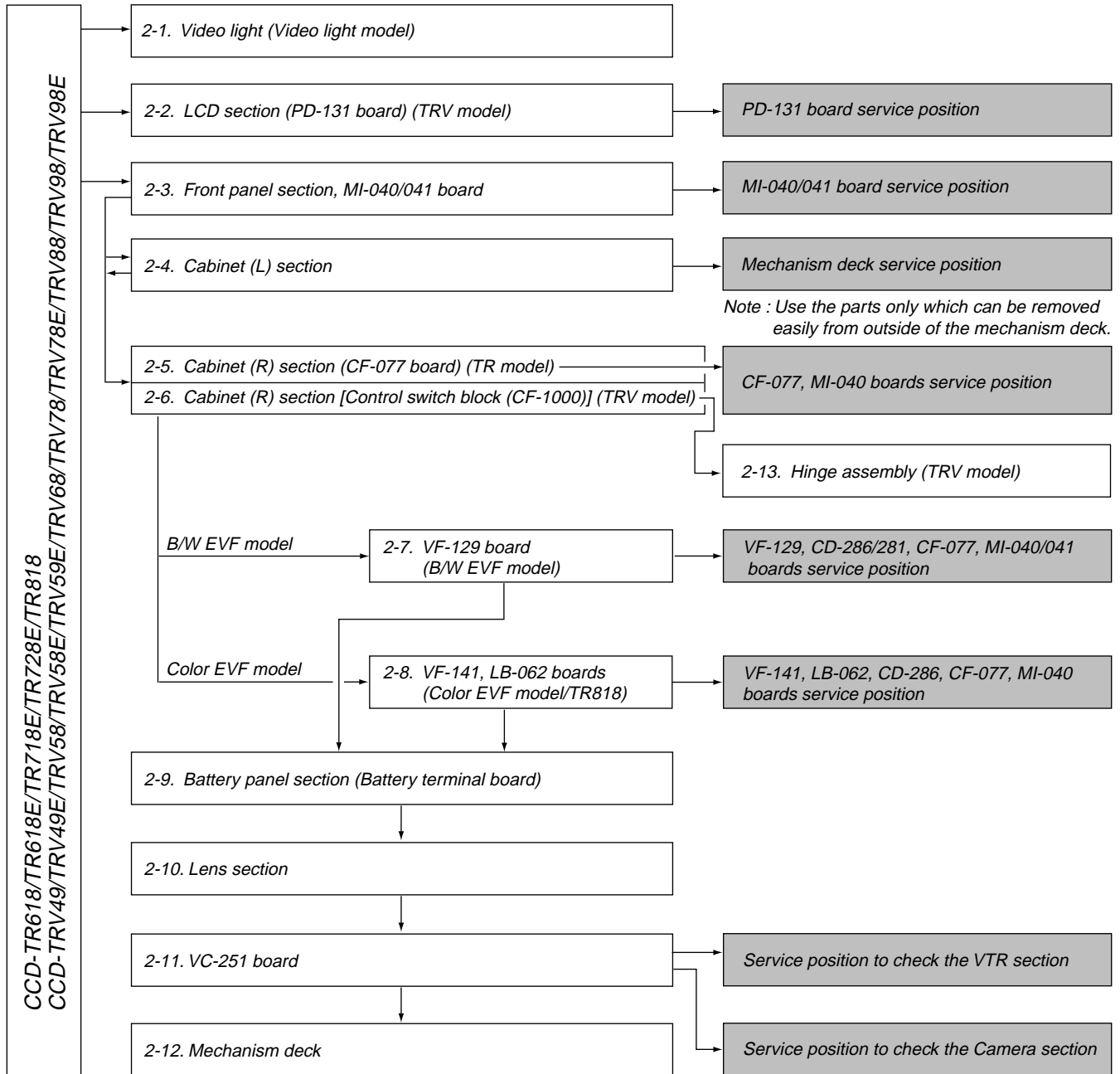

- TR model : CCD-TR618/TR618E/TR718E/TR728E/TR818
- TRV model : CCD-TRV49/TRV49E/TRV58/TRV58E/TRV59E/TRV68/TRV78/TRV78E/TRV88/TRV98/TRV98E
- Video light model : CCD-TR618/TR618E/TR718E/TR728E/
TRV49/TRV49E/TRV58/TRV58E/TRV59E/TRV68/TRV78/TRV78E/TRV88/TRV98/TRV98E
- No video light model : CCD-TR818
- B/W EVF model : CCD-TR618/TR618E/TR718E/TR728E/
TRV49/TRV49E/TRV58/TRV58E/TRV59E/TRV68/TRV78/TRV78E/TRV88/TRV98/TRV98E
- Color EVF model : CCD-TR818

[CONNECTION OF EQUIPMENTS]

(TR MODEL)

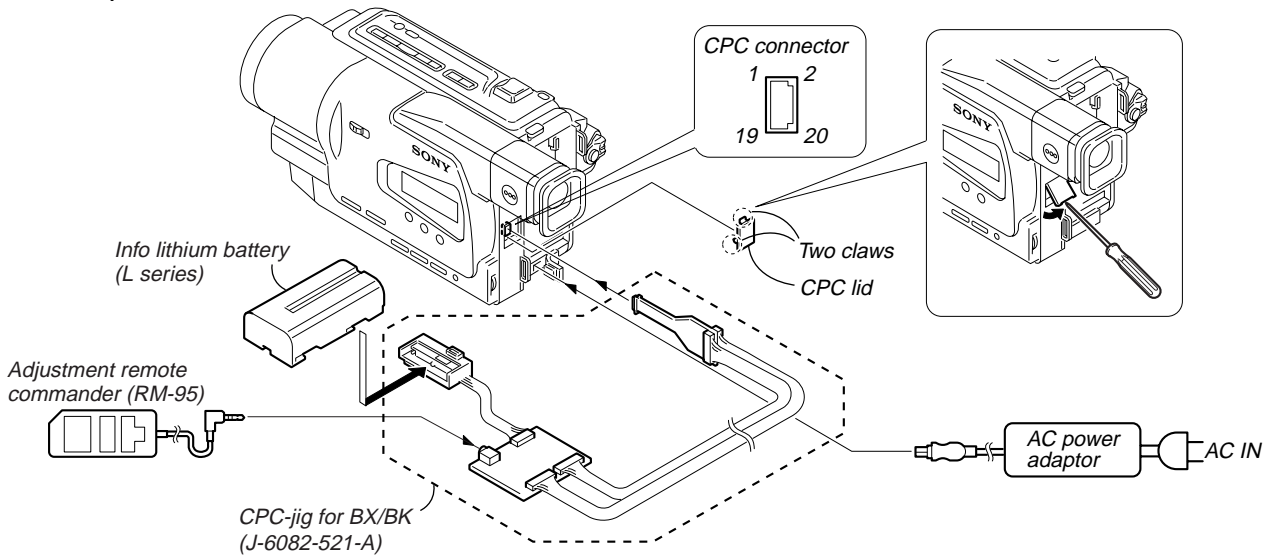

(TRV MODEL)

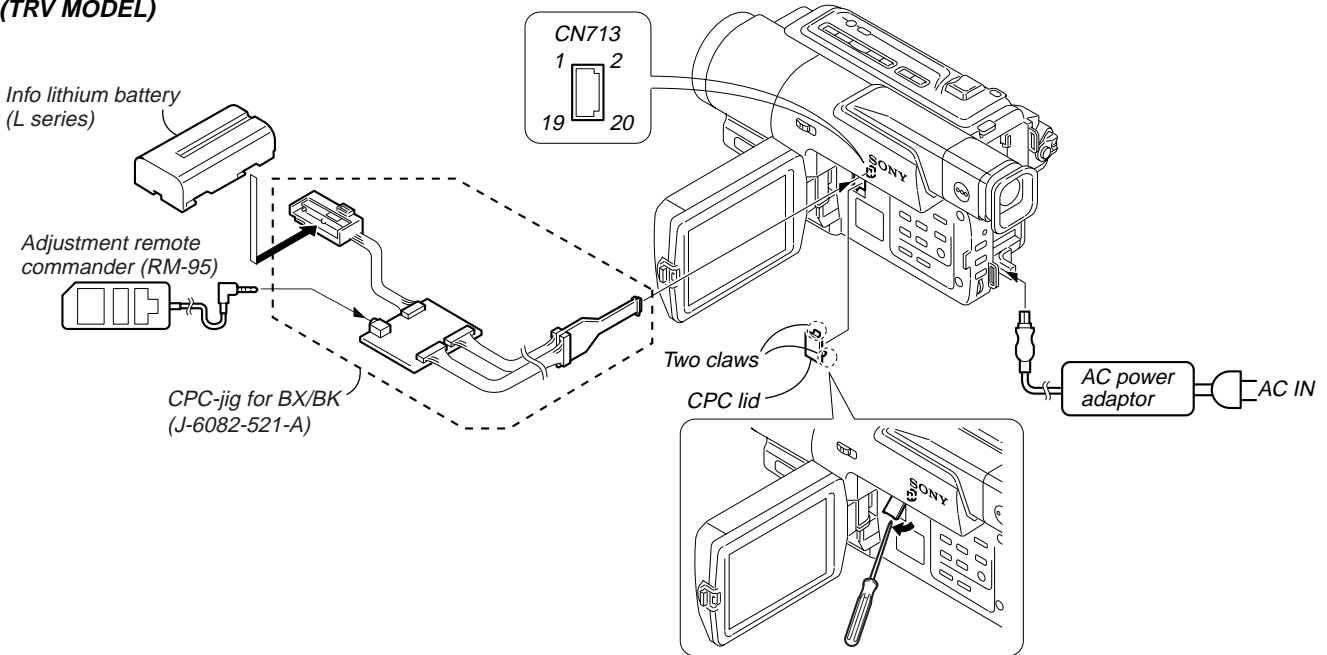

NOTE: Follow the disassembly procedure in the numerical order given.

2-1. VIDEO LIGHT (VIDEO LIGHT MODEL)

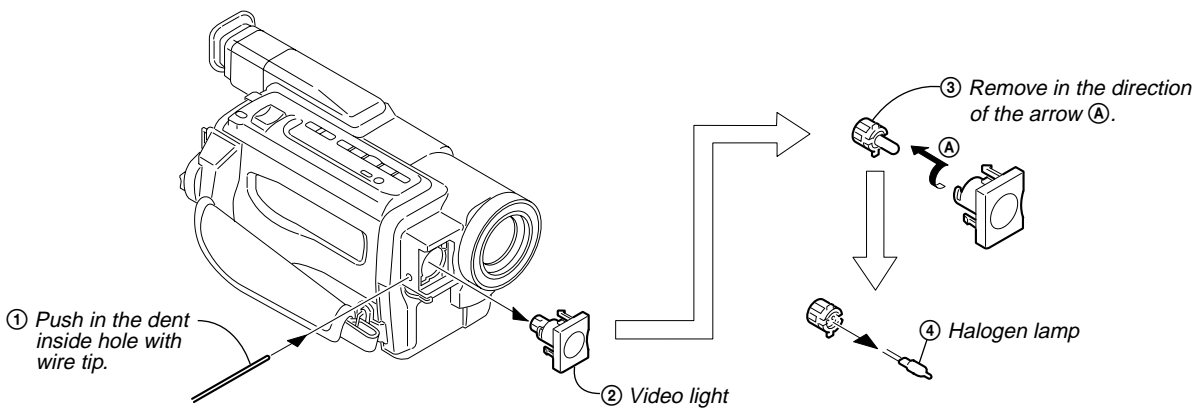

2-2. LCD SECTION (PD-131 BOARD) (TRV MODEL)

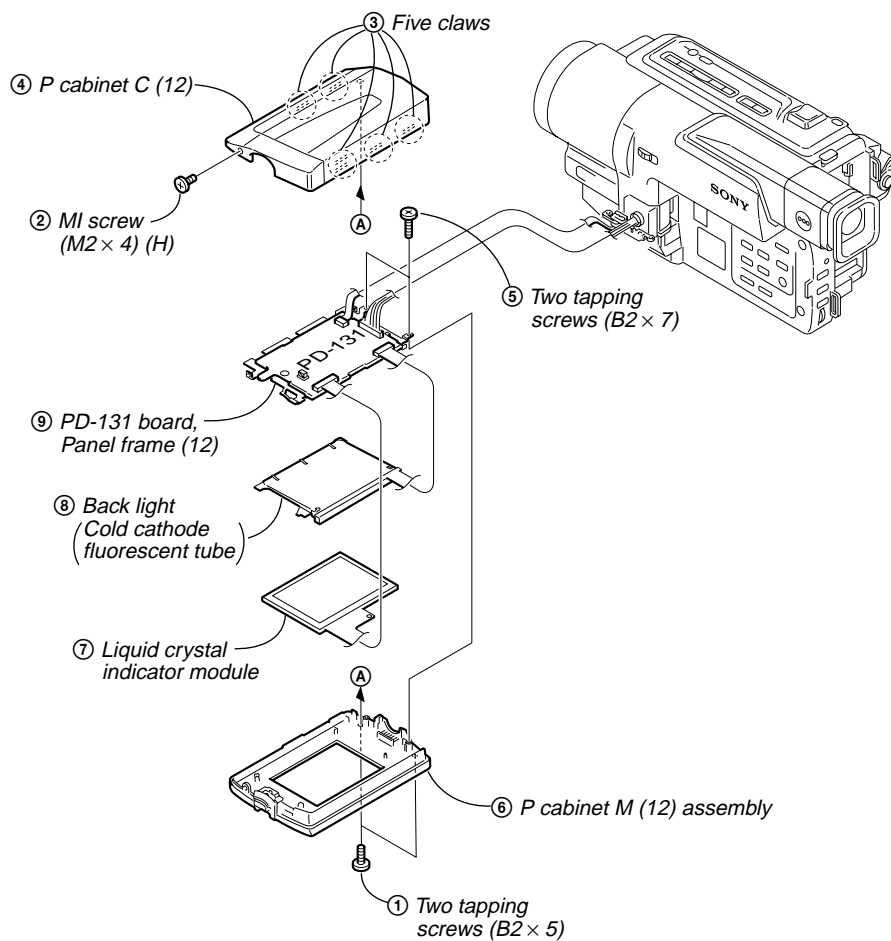

[PD-131 BOARD SERVICE POSITION]

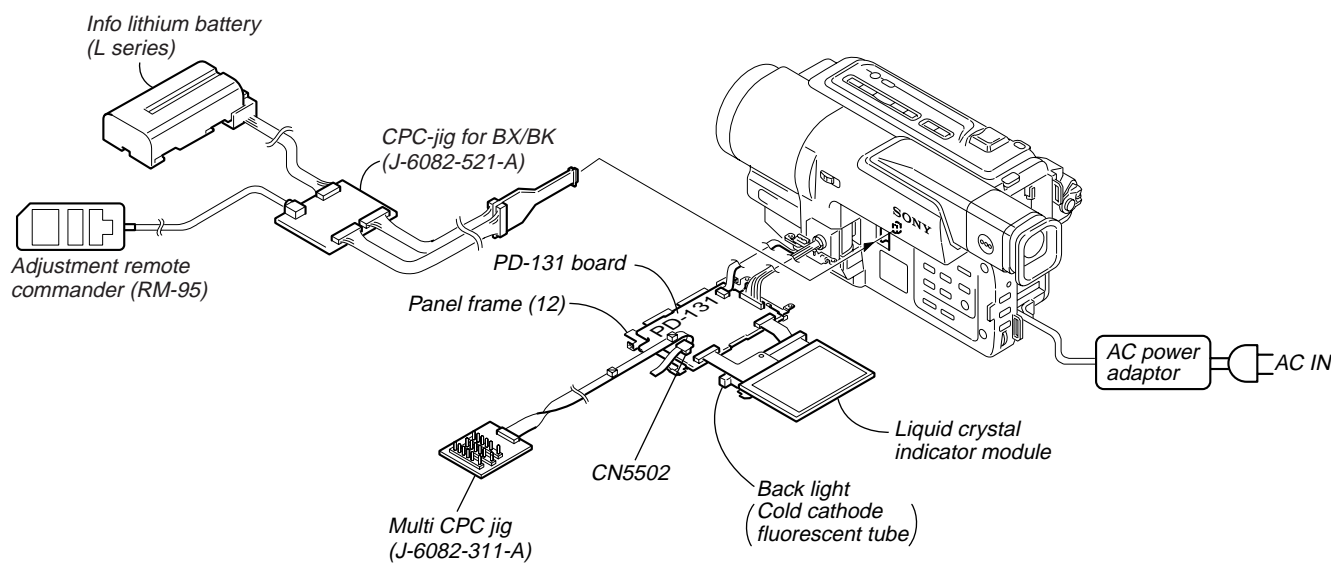

2-3. FRONT PANEL SECTION, MI-040/041 BOARD

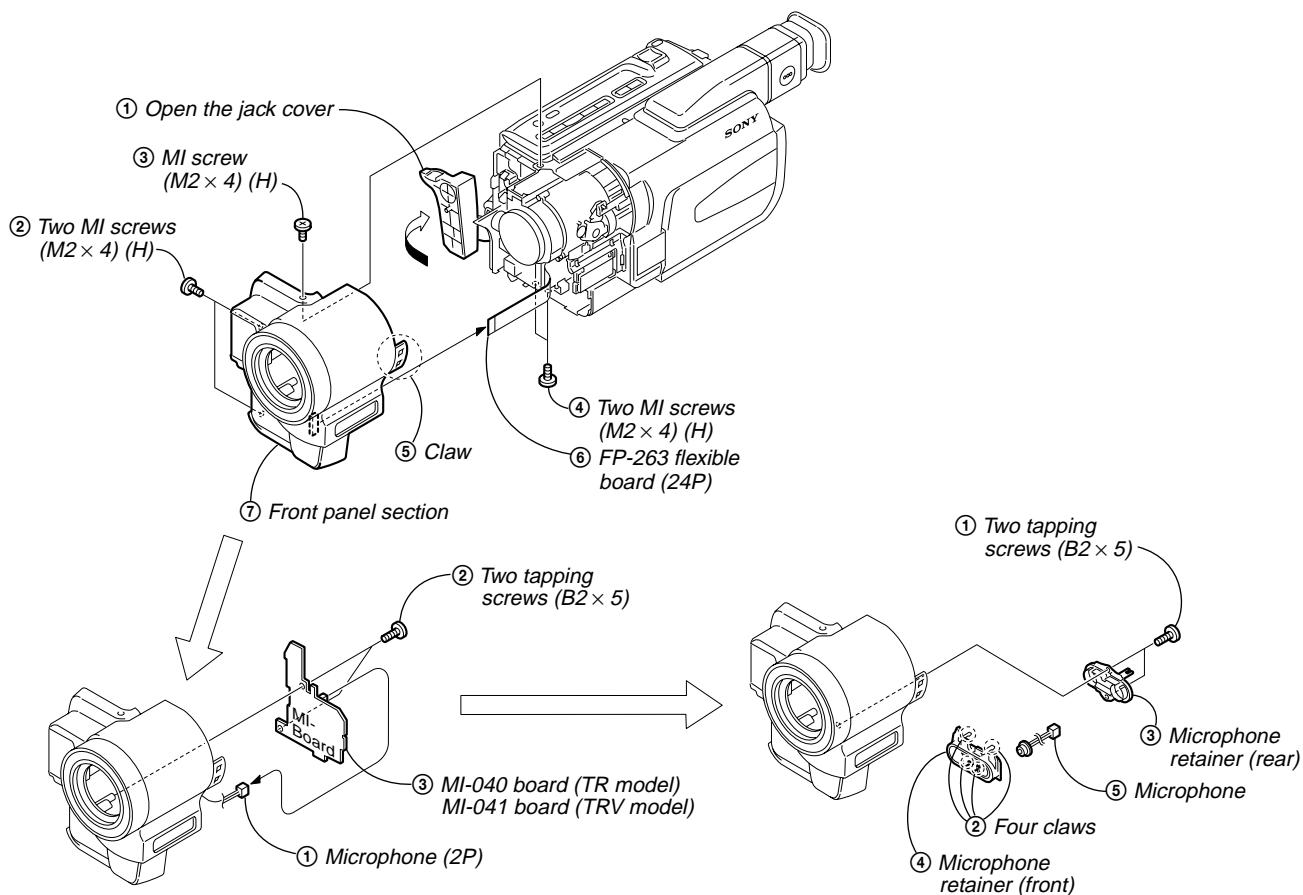

[MI-040/041 BOARD SERVICE POSITION]

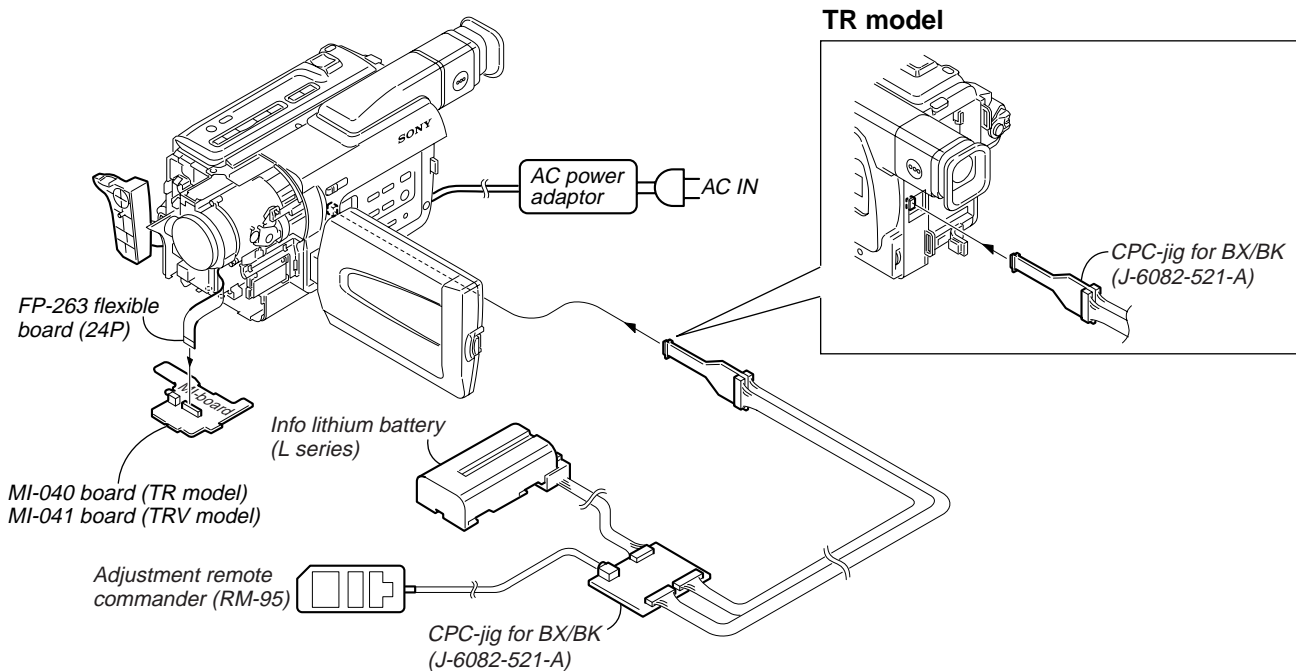

2-4. CABINET (L) SECTION

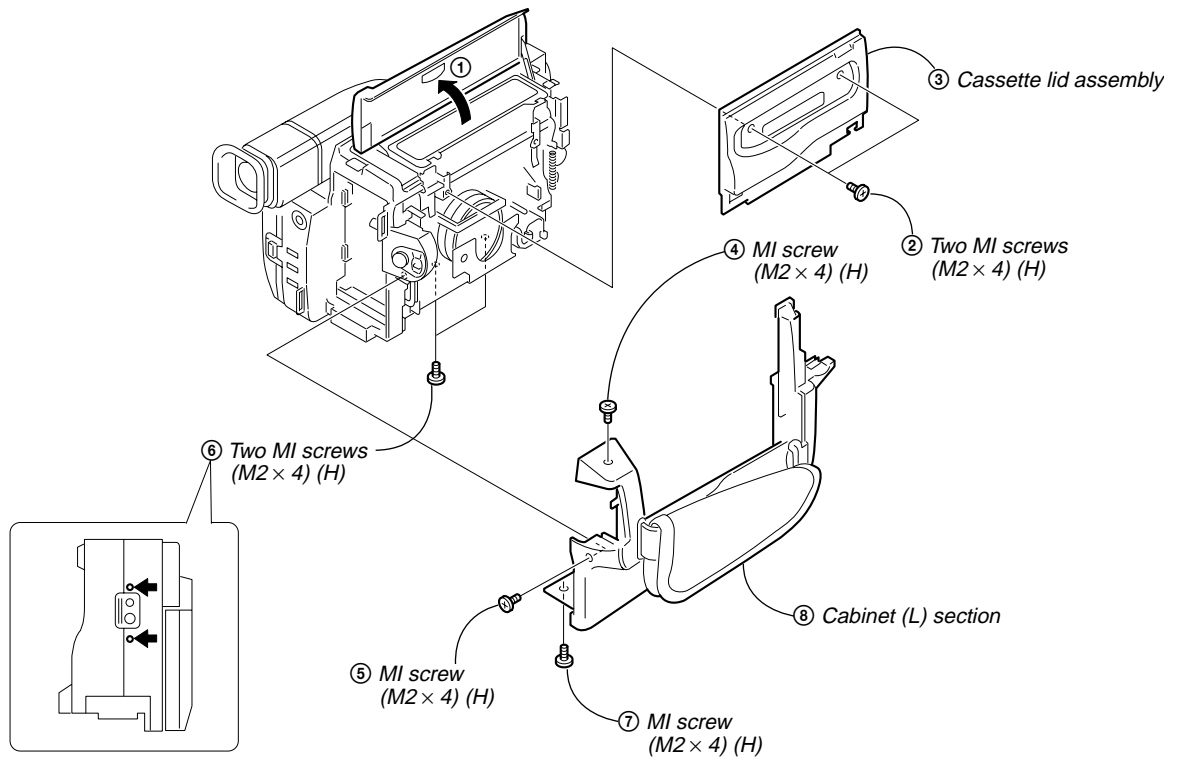

[MECHANISM DECK SERVICE POSITION]

Note: Use the parts only which can be removed easily from outside of the mechanism deck.

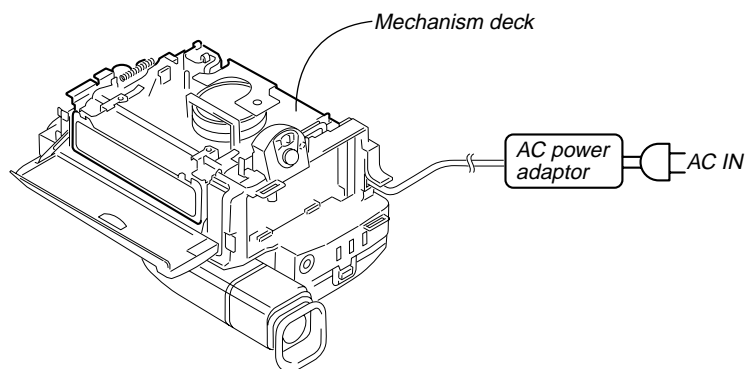

2-5. CABINET (R) SECTION (CF-077 BOARD) (TR MODEL)

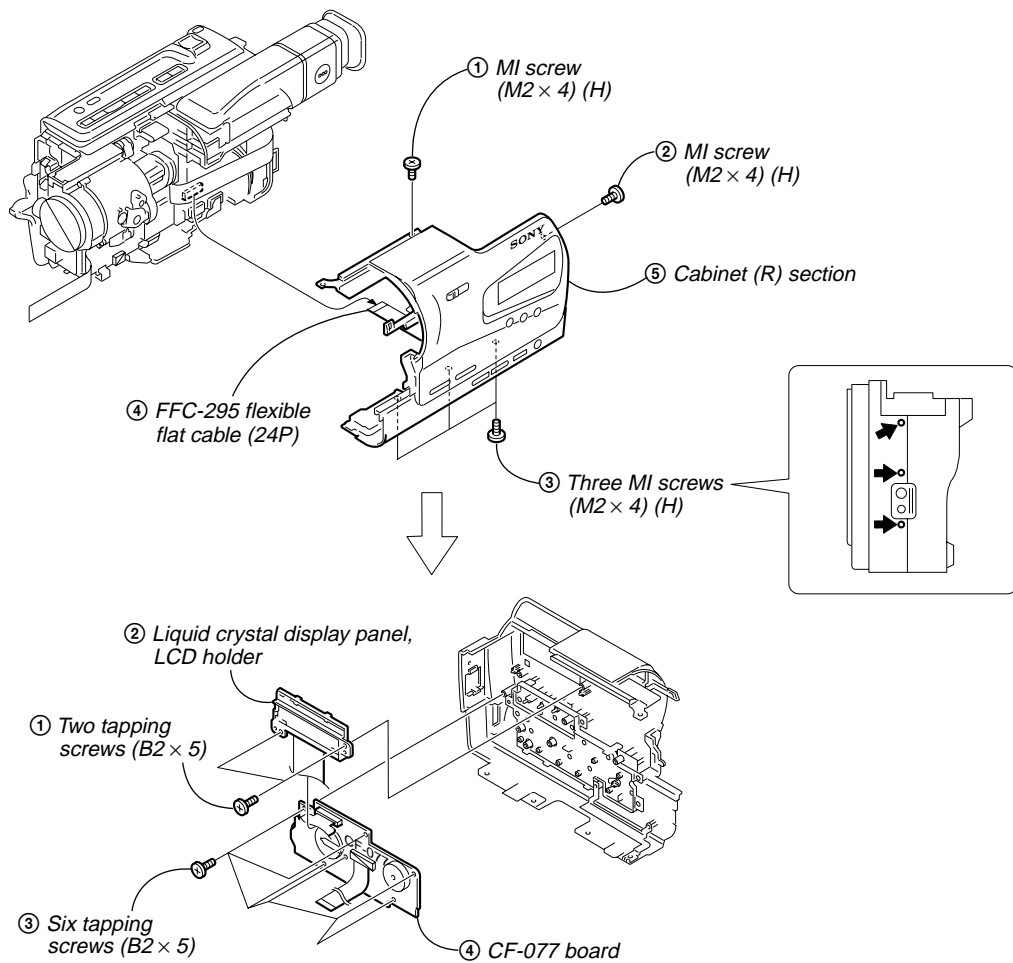

[CF-077, MI-040 BOARDS SERVICE POSITION]

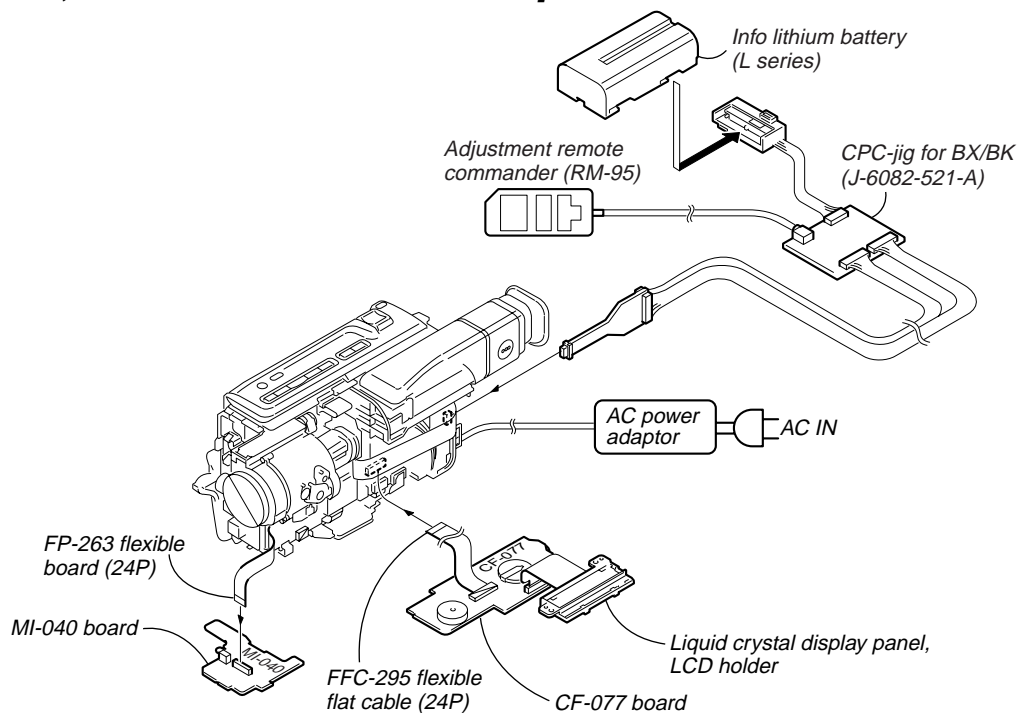

2-6. CABINET (R) SECTION [CONTROL SWITCH BLOCK (CF-1000)] (TRV MODEL)

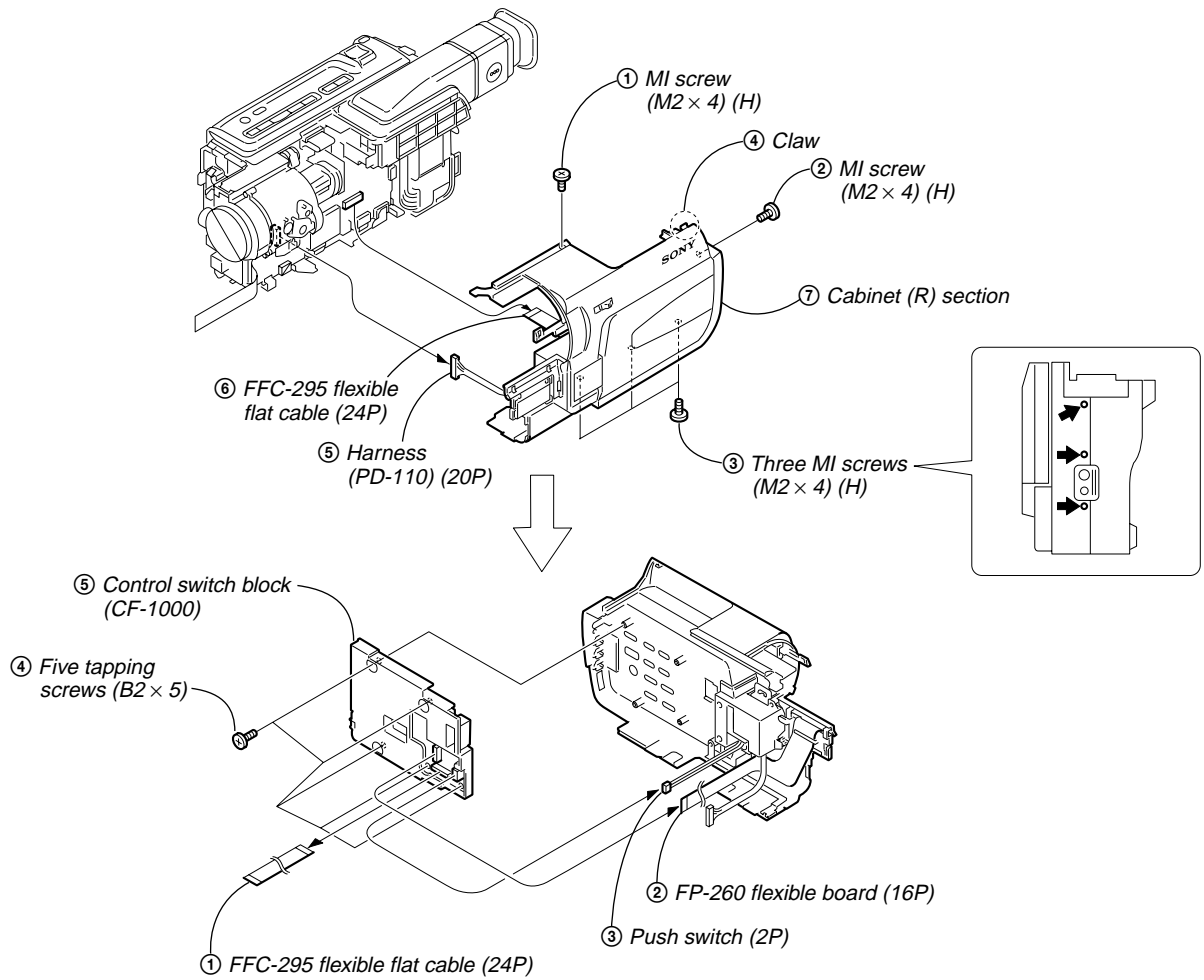

2-7. VF-129 BOARD (B/W EVF MODEL)

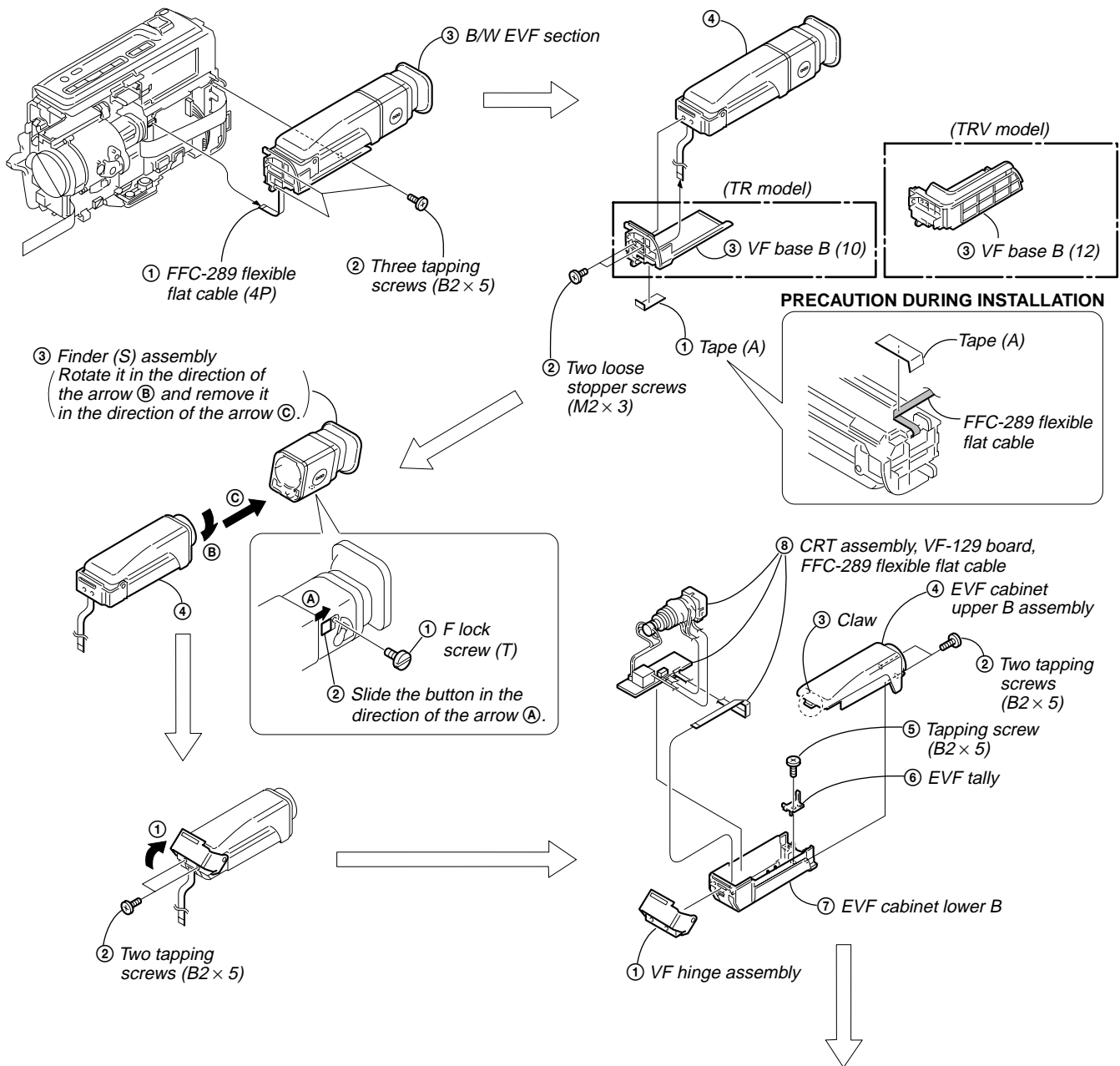

REMOVING THE CRT ASSEMBLY AND VF-129 BOARD

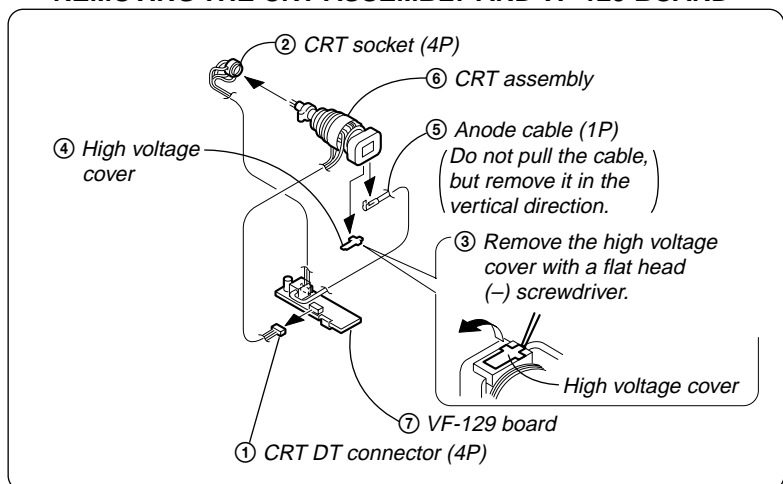

[VF-129, CD-286/281, CF-077, MI-040/041 BOARDS SERVICE POSITION]

TRV model

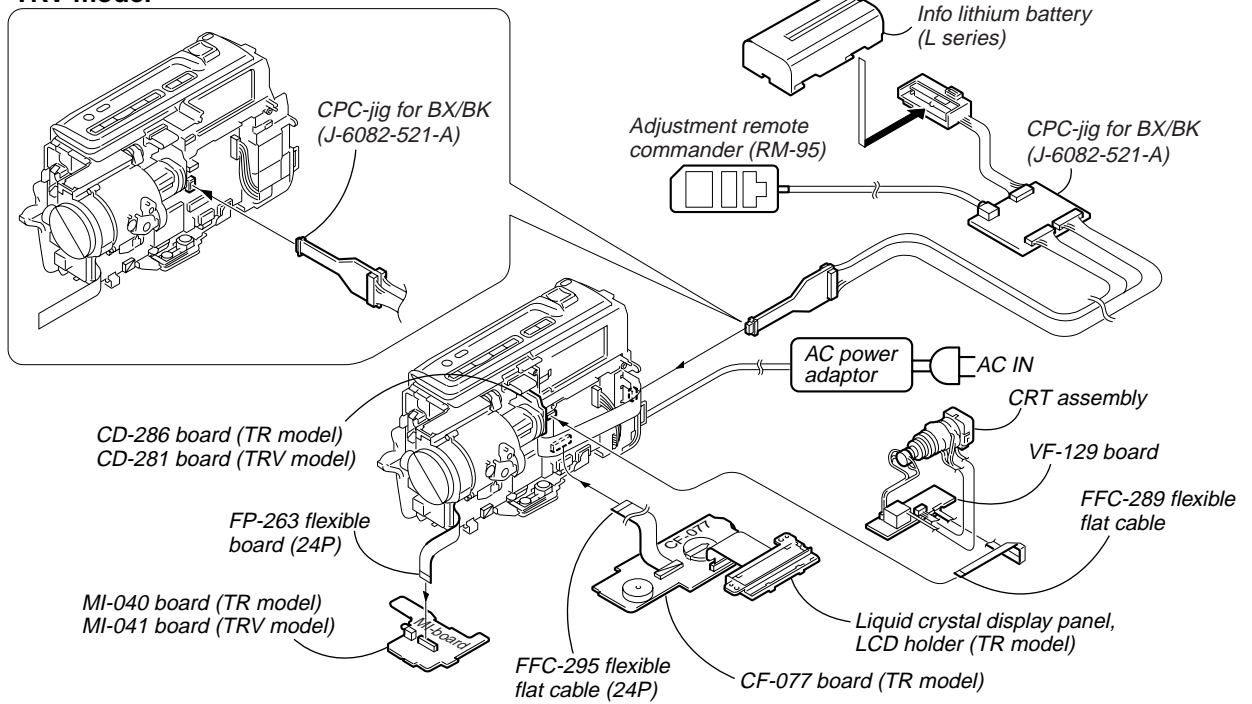

2-8. VF-141, LB-062 BOARDS (COLOR EVF MODEL/TR818)

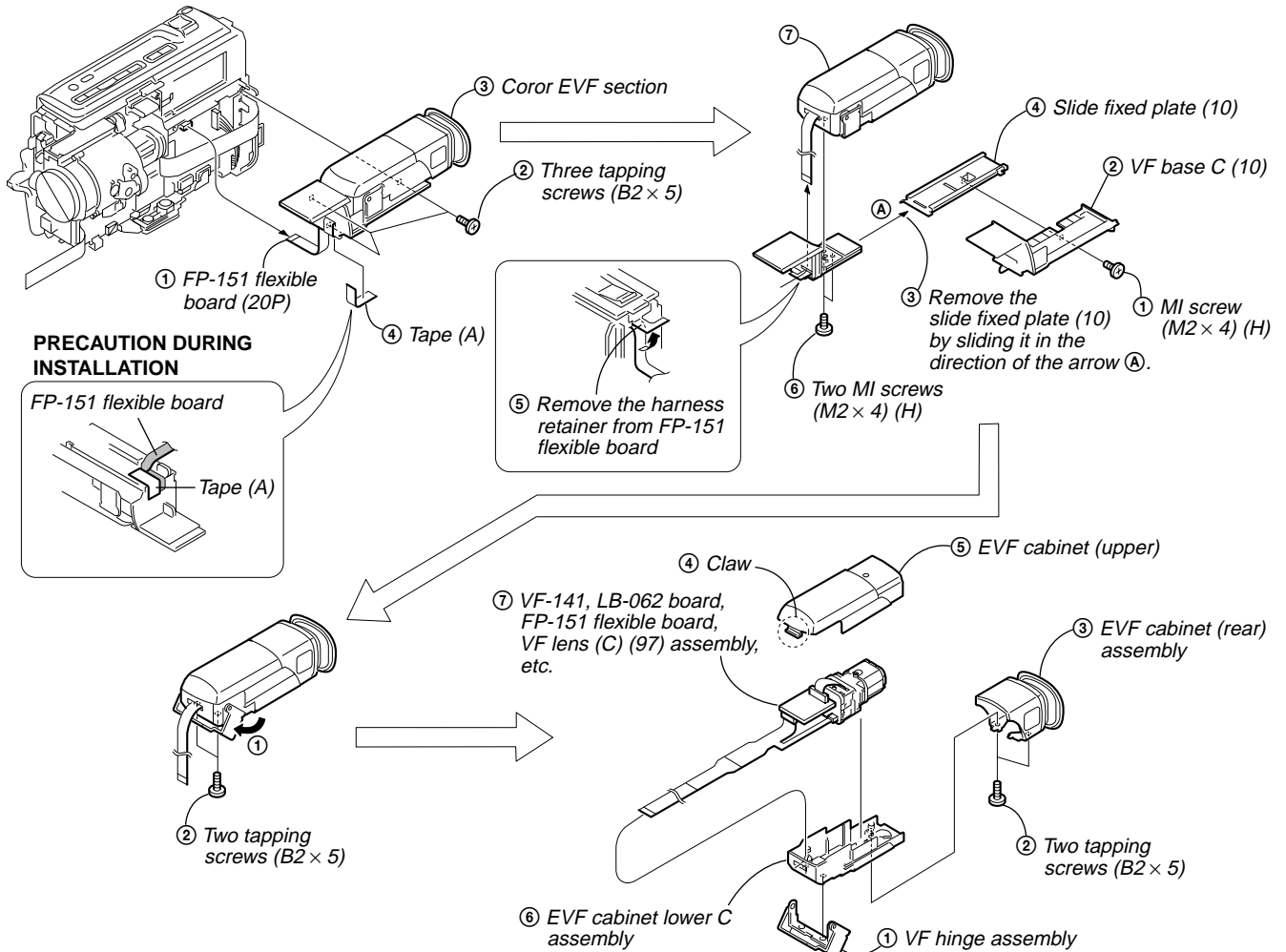

[VF-141, LB-062, CD-286, CF-077, MI-040 BOARDS SERVICE POSITION]

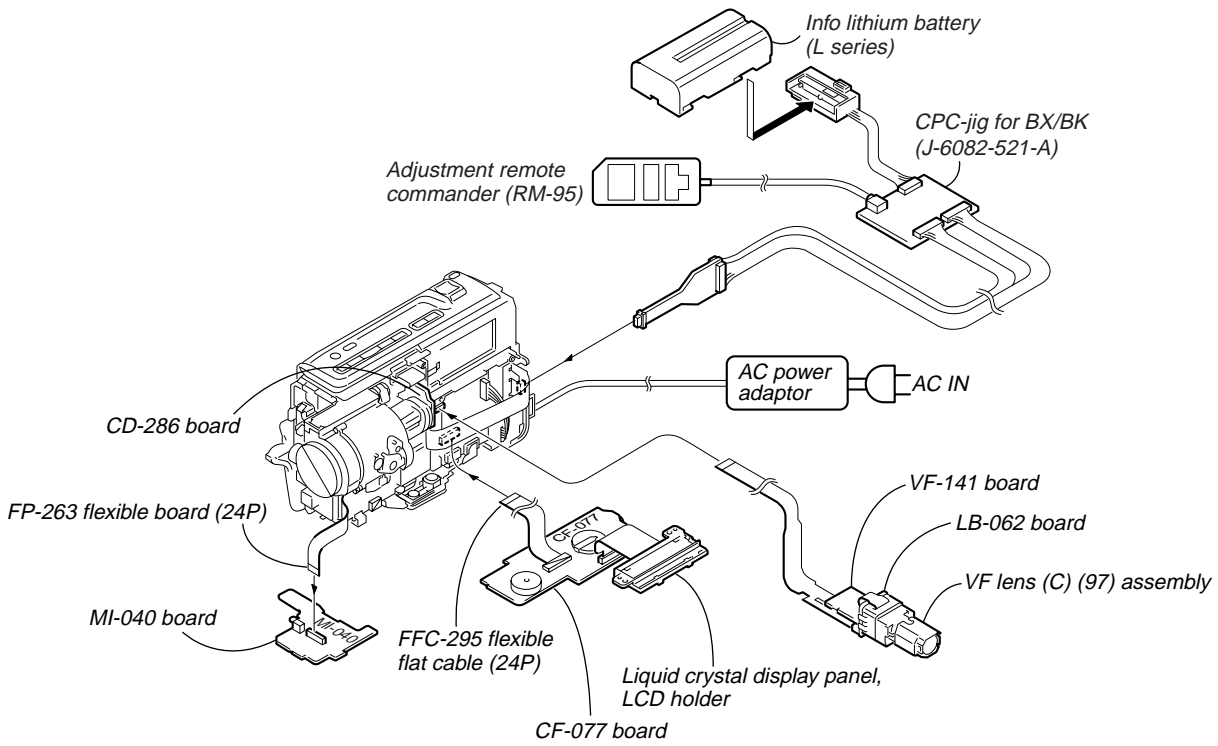

2-9. BATTERY PANEL SECTION (BATTERY TERMINAL BOARD)

(Remove the Cabinet (L) section referring to section 2-4 before starting disassembling.)

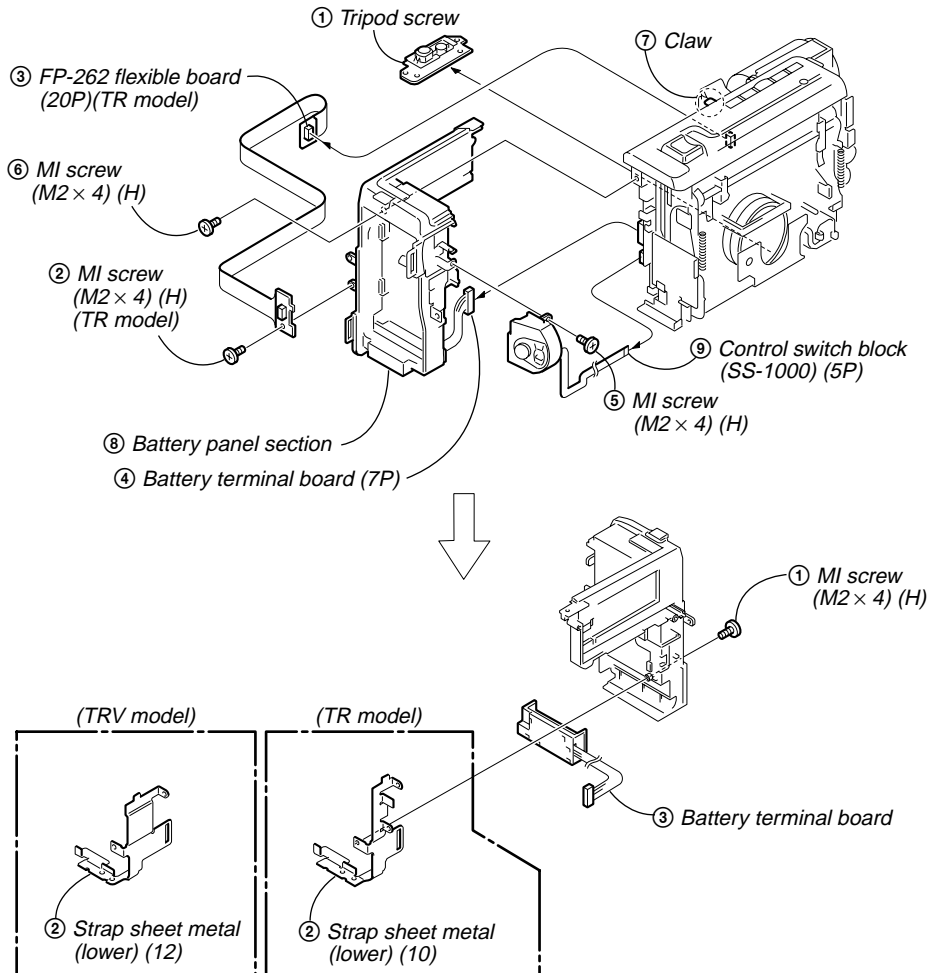

2-10. LENS SECTION

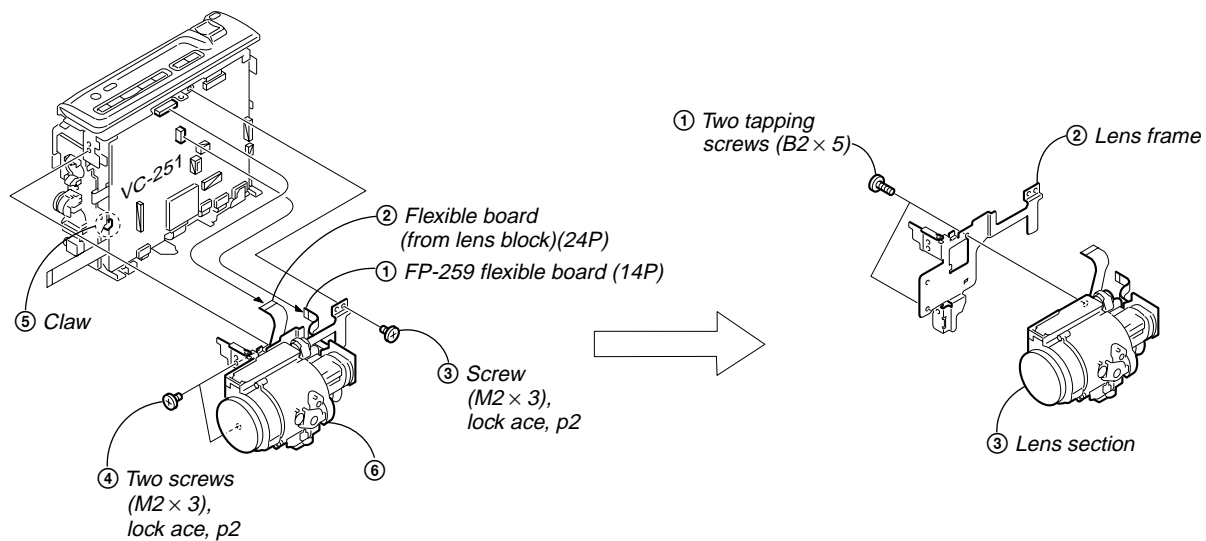

2-11. VC-251 BOARD

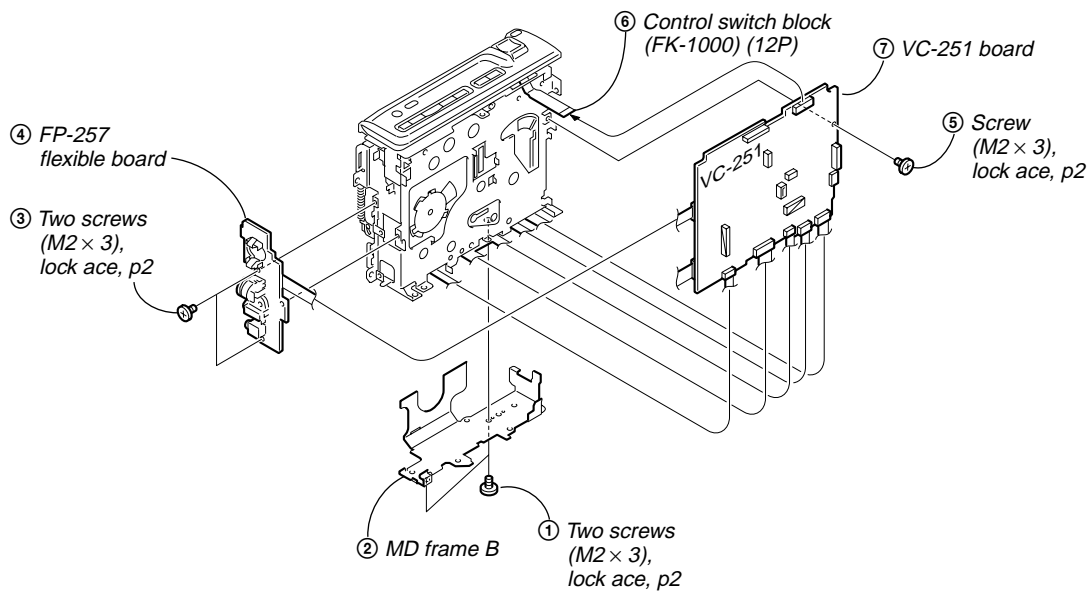

[SERVICE POSITION TO CHECK THE VTR SECTION]

Connection to Check the VTR Section

To check the VTR section, set the VTR to the "Forced VTR power ON" mode.
Operate the VTR functions using the adjustment remote commander (with the HOLD switch set in the OFF position).

Setting the "Forced VTR Power ON" mode

- 1) Select page: 0, address: 01, and set data: 01.
- 2) Select page: D, address: 10, set data: 02, and press the PAUSE button of the adjustment remote commander.

Exiting the "Forced VTR Power ON" mode

- 1) Select page: 0, address: 01, and set data: 01.
- 2) Select page: D, address: 10, set data: 00, and press the PAUSE button of the adjustment remote commander.
- 3) Select page: 0, address: 01, and set data: 00.

Note: If the machine malfunctions (the operating mode changes by itself), connect the FK-1000 block, CF-1000 block/CF-077 board.

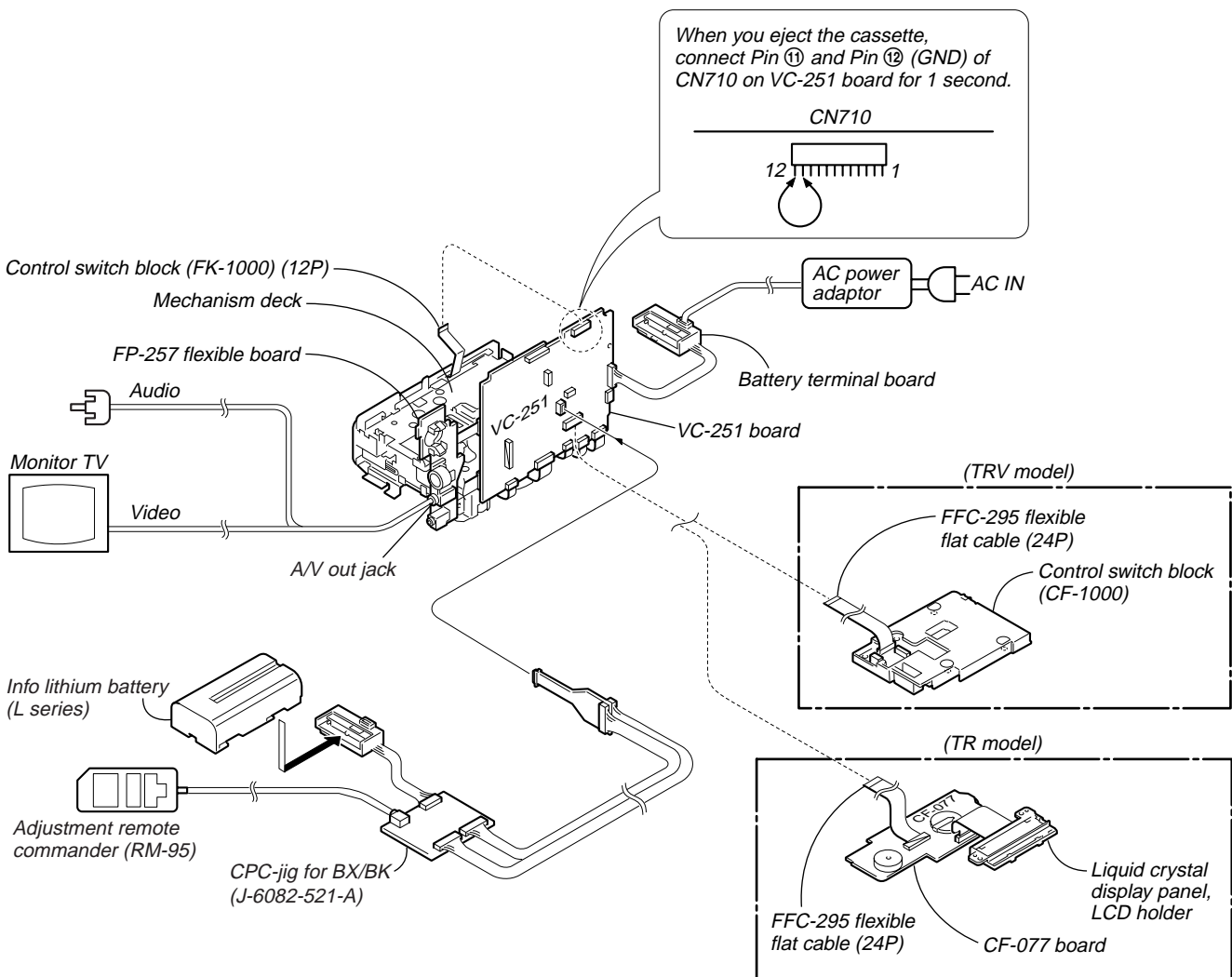

[SERVICE POSITION TO CHECK THE CAMERA SECTION]

Connection to Check the Camera Section

To check the camera section, set the camera to the "Forced camera power ON" mode.

Setting the "Forced Camera Power ON" mode

- 1) Select page: 0, address: 01, and set data: 01.
- 2) Select page: D, address: 10, set data: 01, and press the PAUSE button of the adjustment remote commander.

Exiting the "Forced Camera Power ON" mode

- 1) Select page: 0, address: 01, and set data: 01.
- 2) Select page: D, address: 10, set data: 00, and press the PAUSE button of the adjustment remote commander.
- 3) Select page: 0, address: 01, and set data: 00.

Note: If the machine malfunctions (the operating mode changes by itself), connect the FK-1000 block, CF-1000 block/CF-077 board.

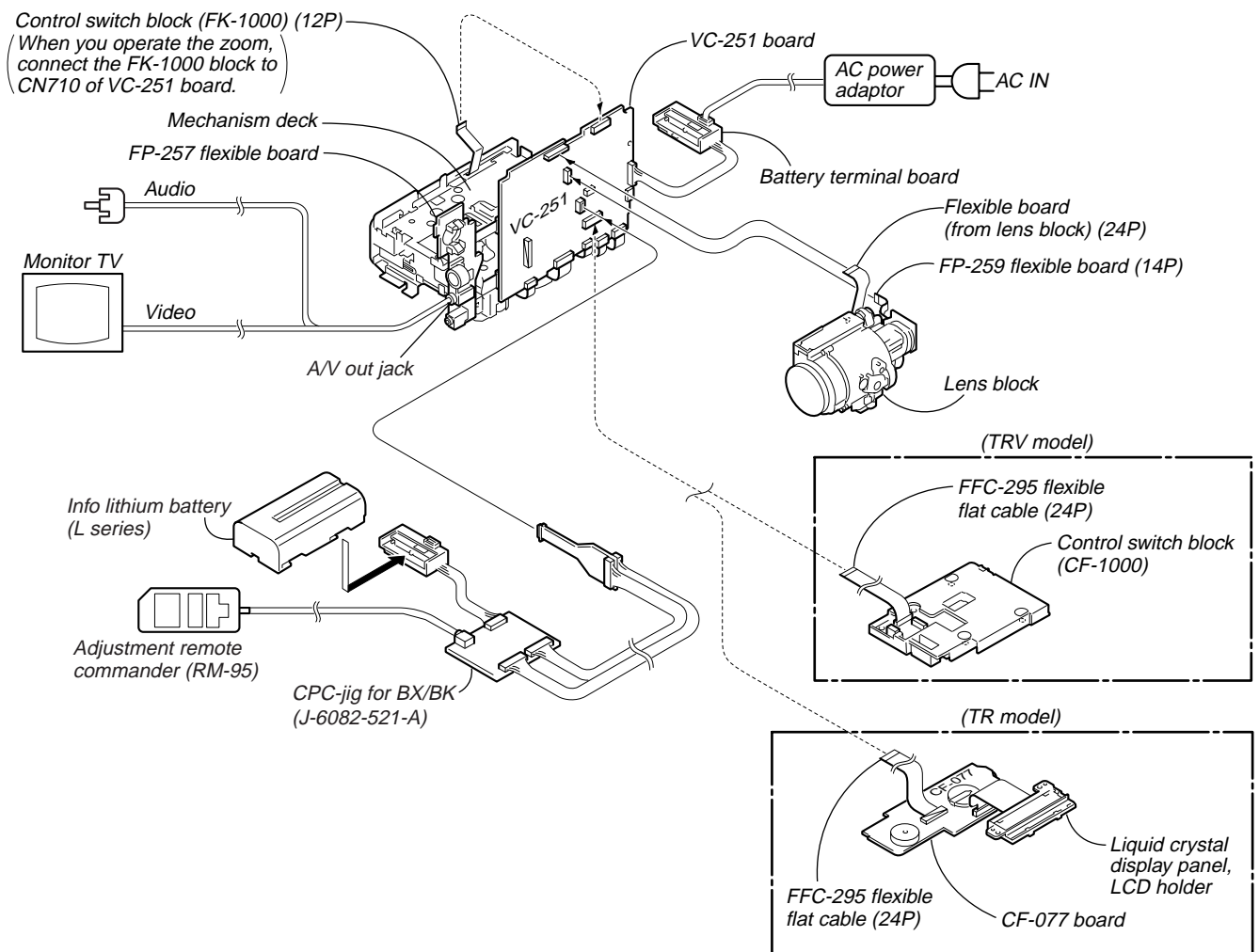

2-12. MECHANISM DECK

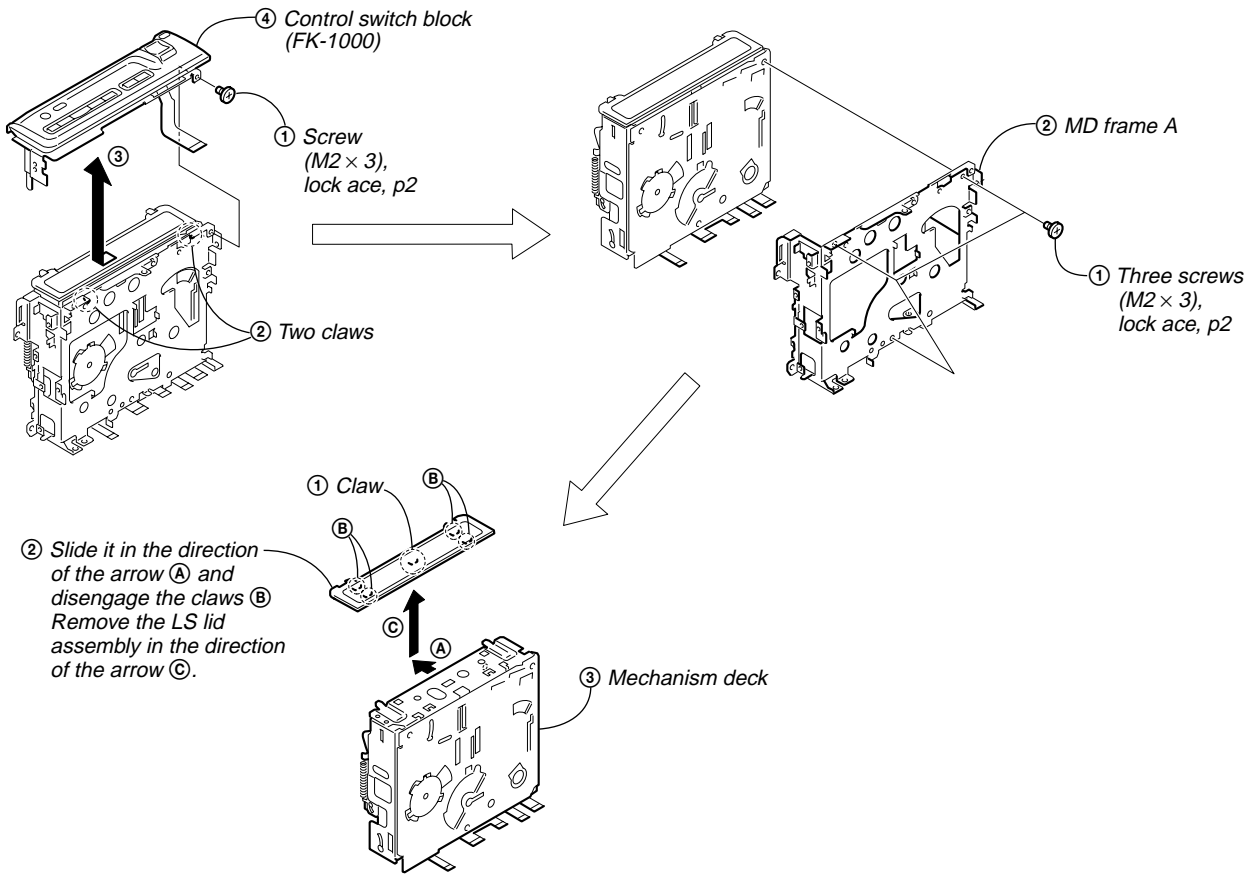

2-13. HINGE ASSEMBLY (TRV MODEL)

(Remove the LCD unit referring to section 2-2 before starting disassembling.)

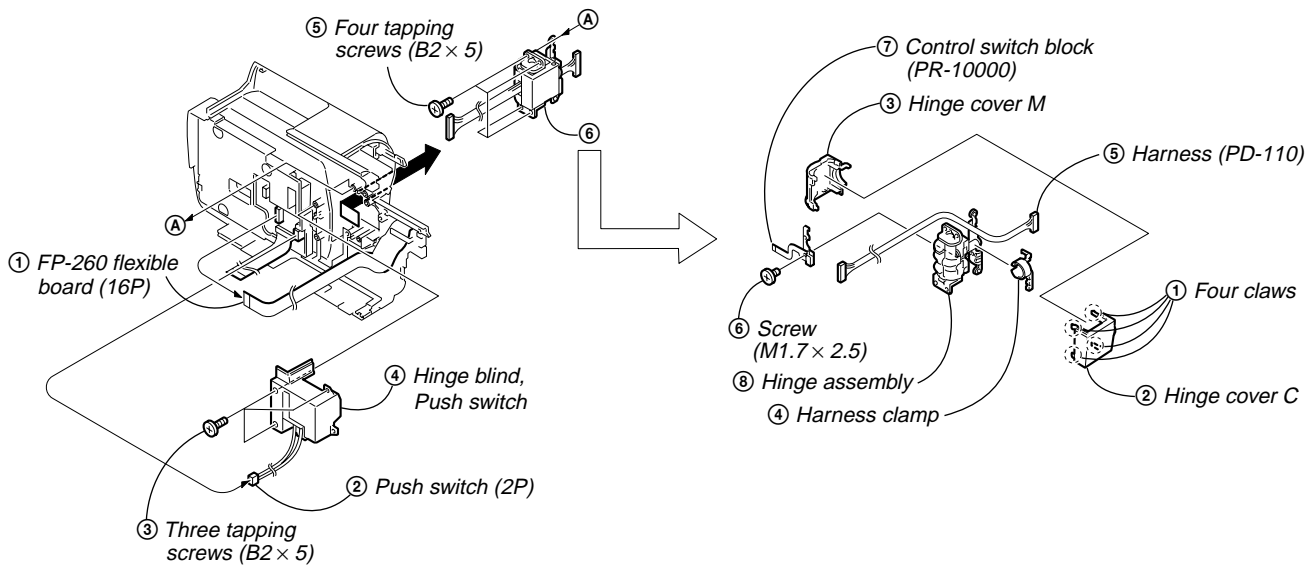

2-14. CIRCUIT BOARDS LOCATION

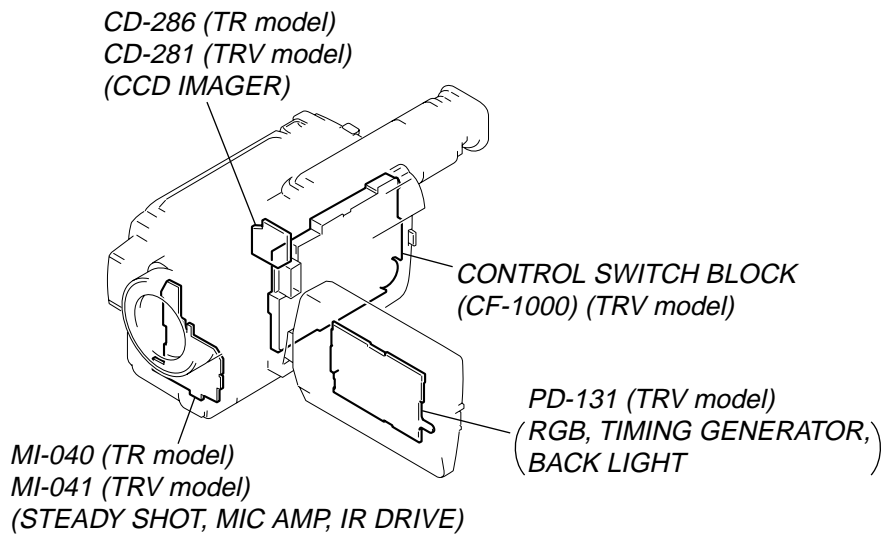

VC-251
 (CAMERA PROCESSOR, Y/C PROCESSOR,
 FOCUS/ZOOM MOTOR DRIVE, REC PB AMP,
 LINE I/O AMP, SERVO, MODE CONTROL,
 HI CONTROL, AUDIO, DC/DC CONVERTER)

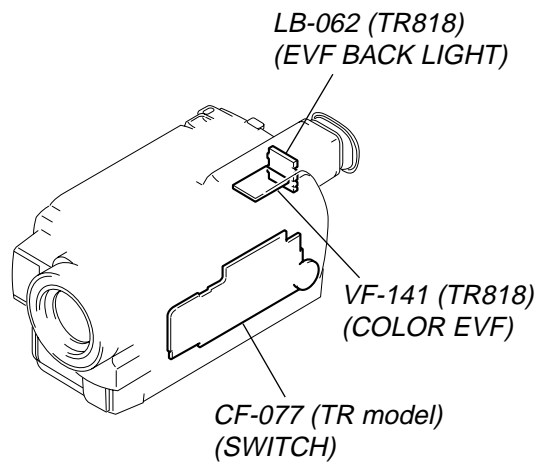
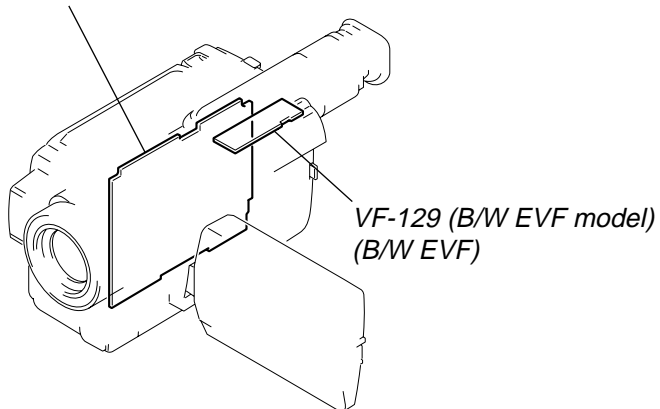

2-15. FLEXIBLE BOARDS LOCATION

The flexible boards contained in the mechanism deck are not shown.

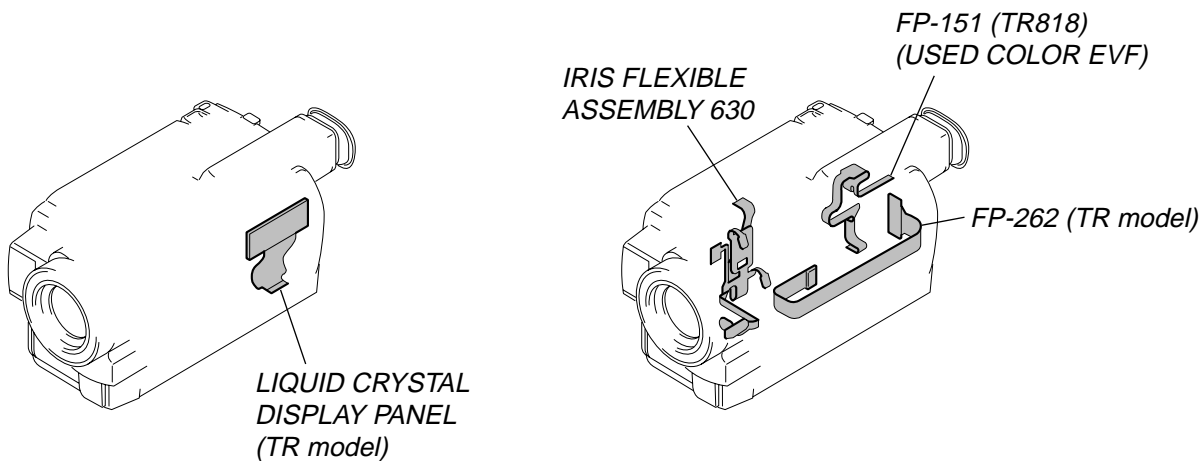
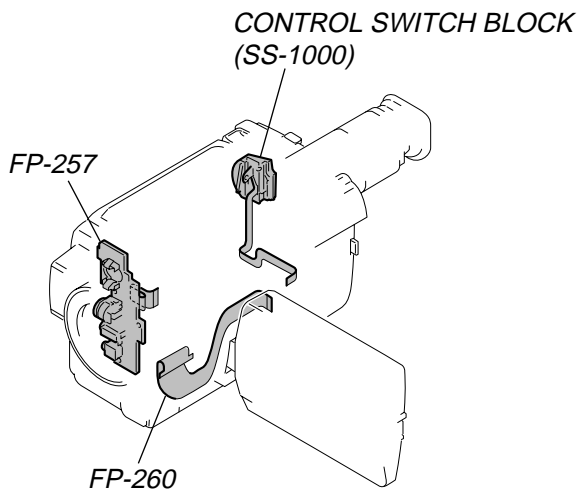
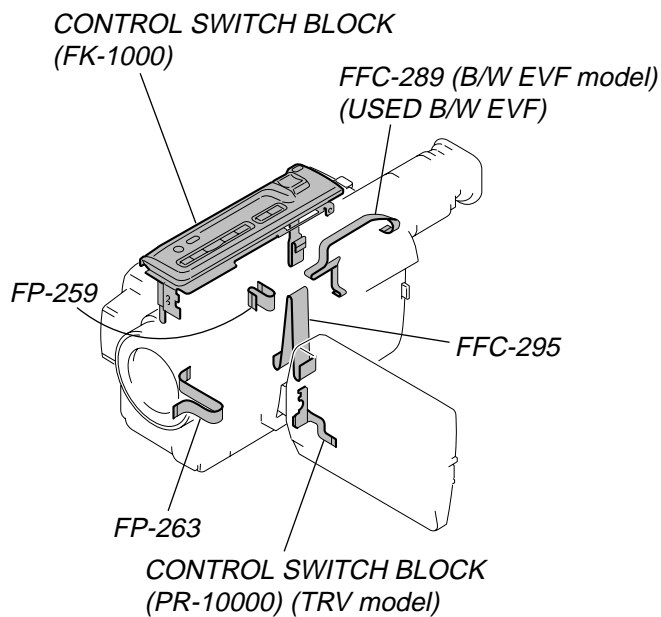

CCD-TR618/TR618E/TR718E/TR728E/TR818/TRV49/TRV49E/TRV58/
TRV58E/TRV59E/TRV68/TRV78/TRV78E/TRV88/TRV98/TRV98E

SECTION 3
BLOCK DIAGRAMS

3-1. OVERALL BLOCK DIAGRAM (1/2) () : Page No. shown in () indicates the page to refer on the schematic diagram.

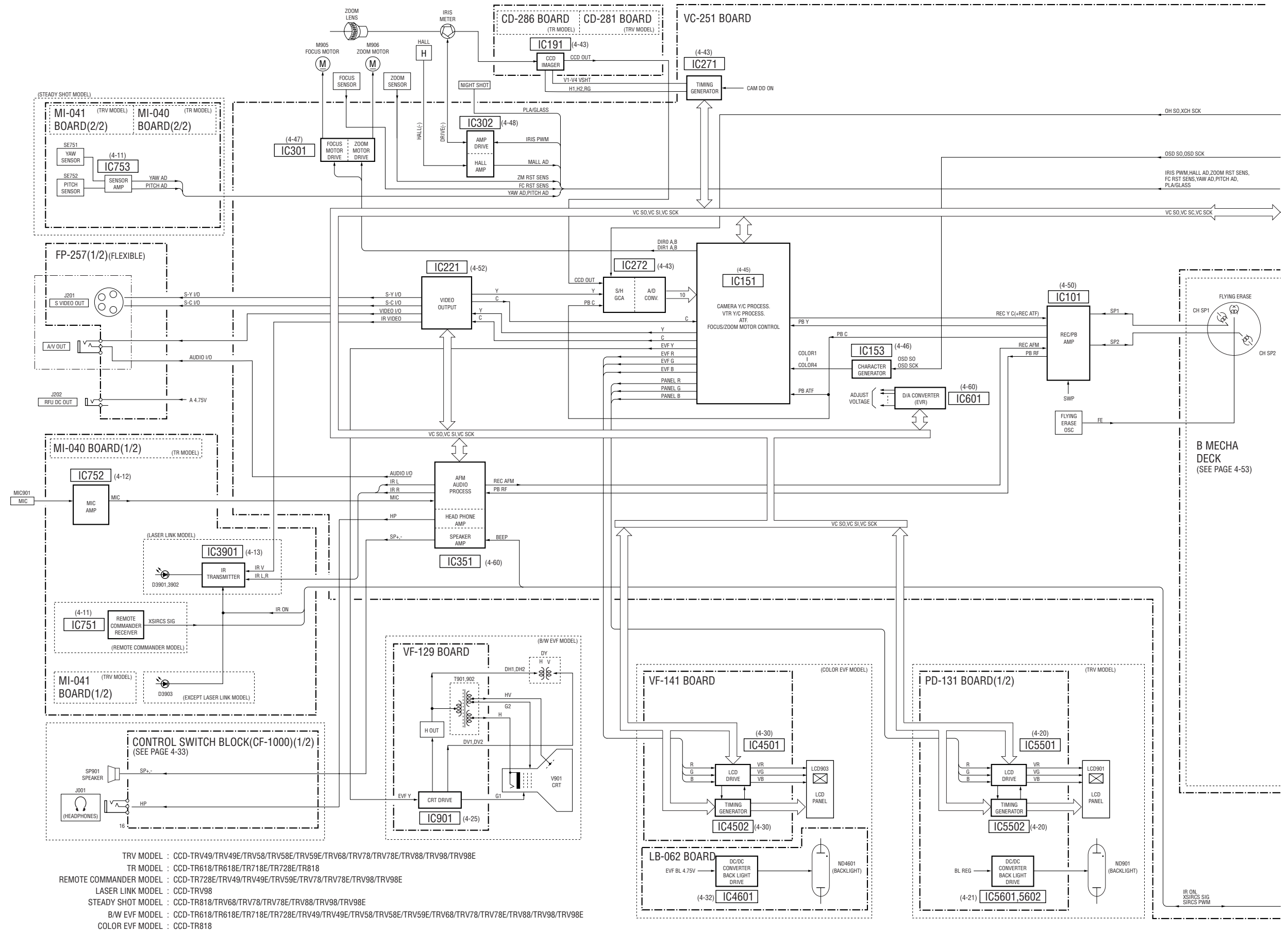

3-2. OVERALL BLOCK DIAGRAM (2/2) () : Page No. shown in () indicates the page to refer on the schematic diagram.

TRV MODEL : CCD-TRV49/TRV49E/TRV58/TRV58E/TRV59E/TRV68/TRV78/TRV78E/TRV88/TRV98/TRV98E
TR MODEL : CCD-TR618/TR618E/TR718E/TR728E/TR818
VIDEO LIGHT MODEL : CCD-TR618/TR618E/TR718E/TR728E/TRV49/TRV49E/TRV58/TRV58E/TRV59E/TRV68/TRV78/TRV78E/TRV88/TRV98/TRV98E
COLOR EVF MODEL : CCD-TR818

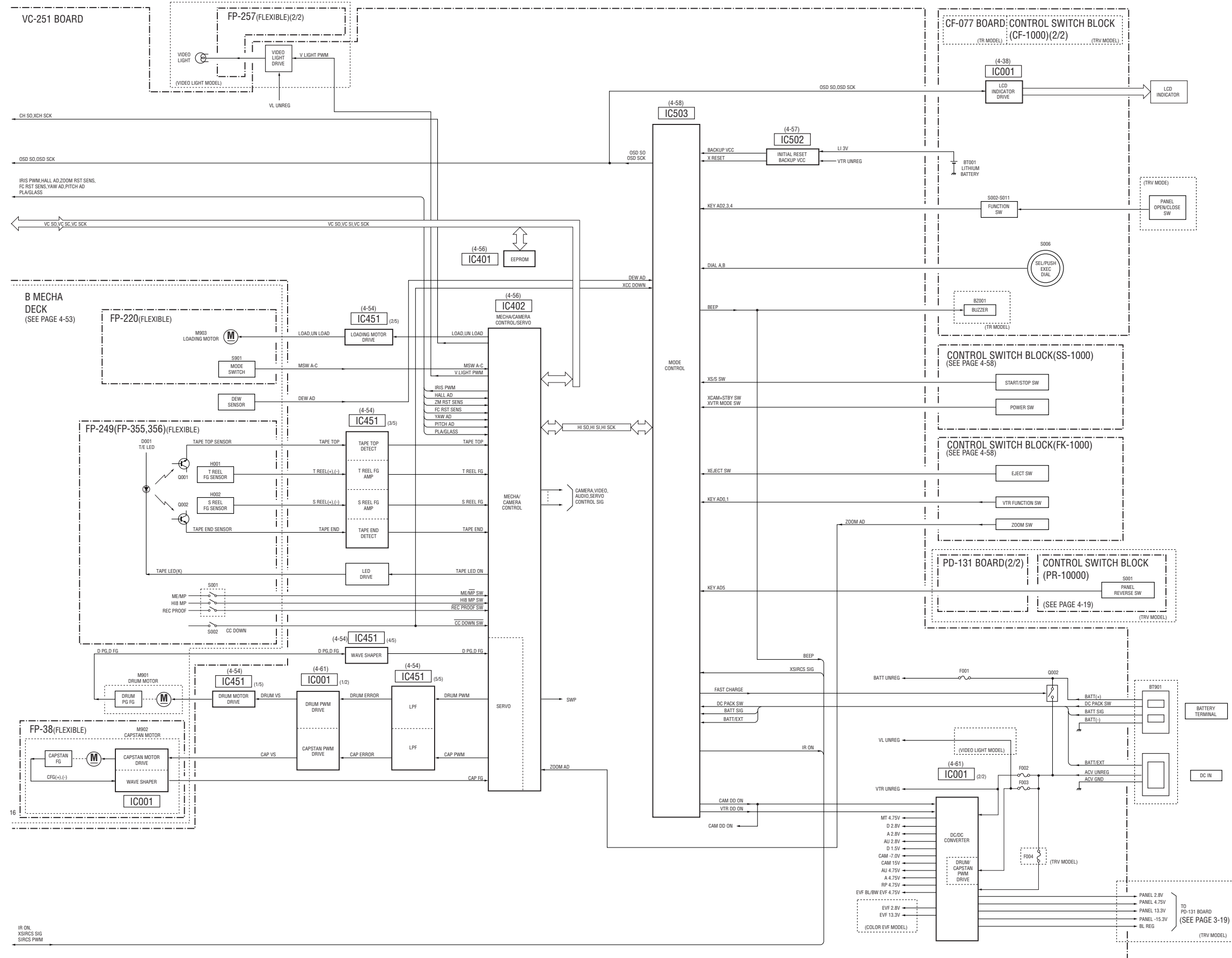

3-3. CAMERA/VIDEO BLOCK DIAGRAM (1/2) () : Page No. shown in () indicates the page to refer on the schematic diagram.

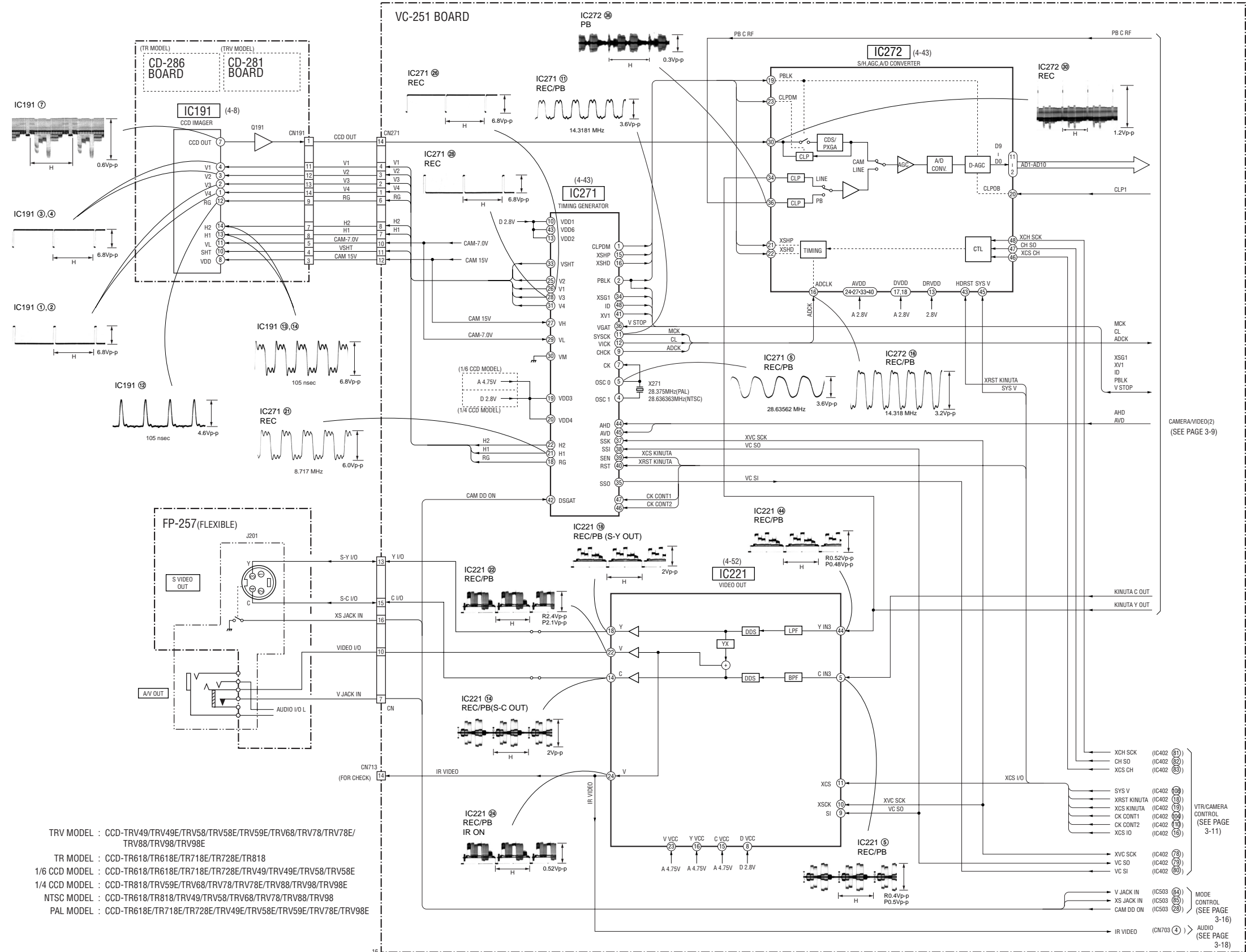

3-4. CAMERA/VIDEO BLOCK DIAGRAM (2/2) () : Page No. shown in () indicates the page to refer on the schematic diagram.

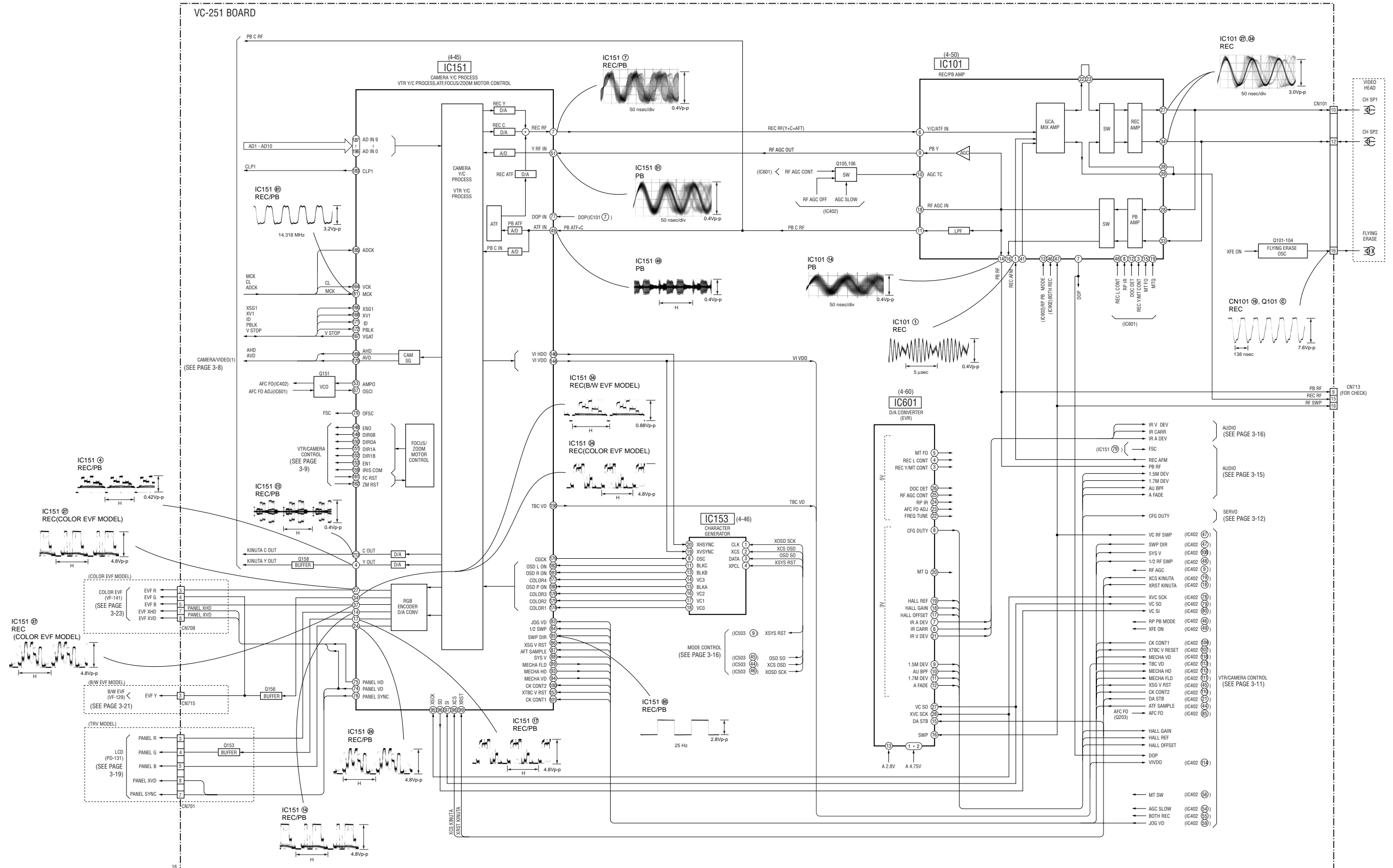

TRV MODEL : CCD-TRV49/TRV49E/TRV58/TRV58E/TRV59E/TRV68/TRV78/TRV78E/
TRV88/TRV98/TRV98E
B/W EVF MODEL : CCD-TR618/TR618E/TR718E/TR728E/TRV49/TRV49E/TRV58/TRV58E/TRV68/TRV78/TRV78E/TRV88/TRV98/TRV98E
COLOR EVF MODEL : CCD-TR818

3-5. VTR/CAMERA CONTROL BLOCK DIAGRAM () : Page No. shown in () indicates the page to refer on the schematic diagram.

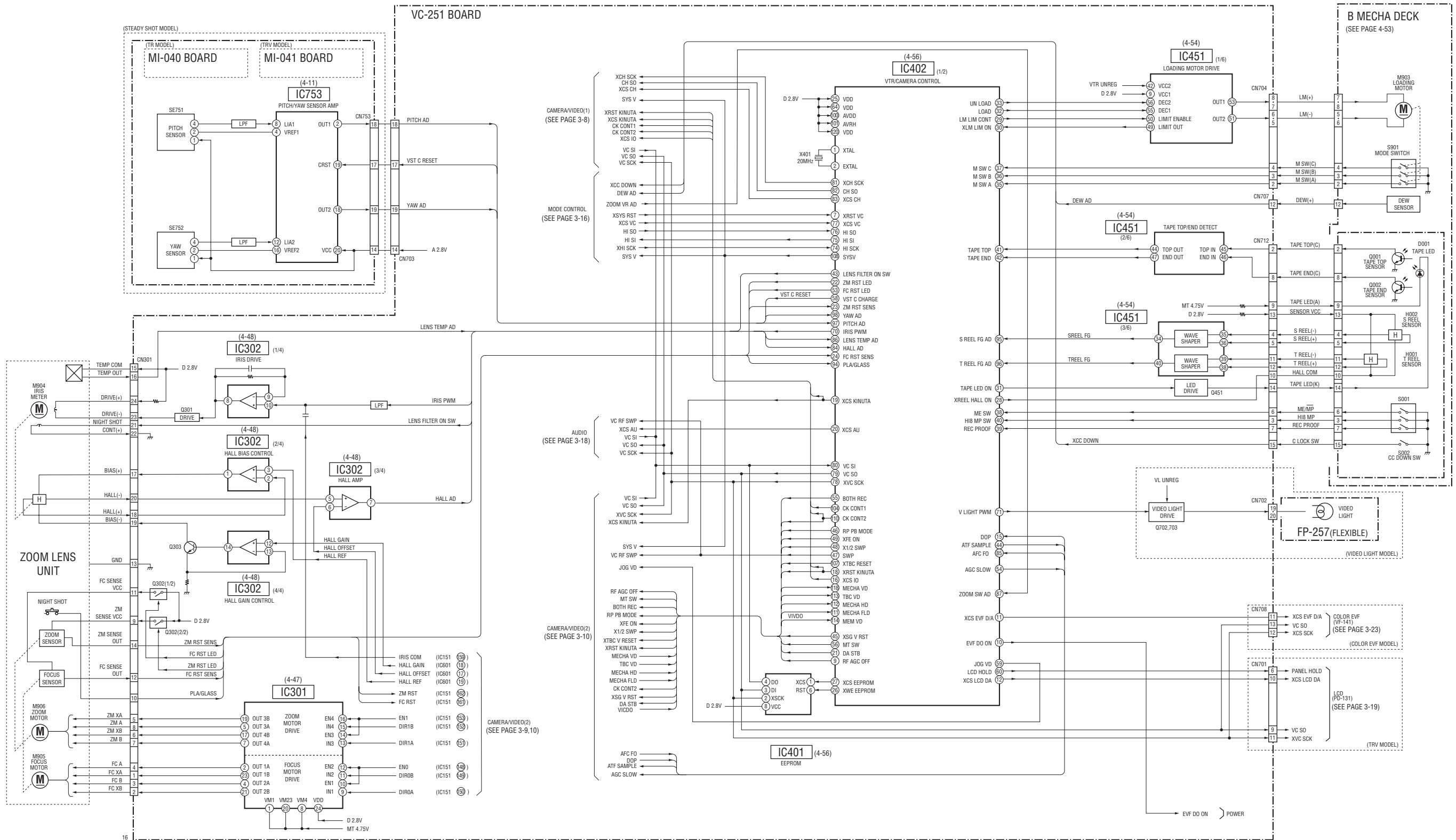

TRV MODEL : CCD-TRV49/TRV49E/TRV58/TRV58E/TRV59E/TRV68/TRV78/TRV78E/TRV88/TRV98/TRV98E
 TR MODEL : CCD-TR618/TR618E/TR718E/TR728E/TR818
 VIDEO LIGHT MODEL : CCD-TR618/TR618E/TR718E/TR728E/TRV49/TRV49E/TRV58/TRV58E/TRV59E/TRV68/TRV78/TRV78E/TRV88/TRV98/TRV98E
 STEADY SHOT MODEL : CCD-TR818/TRV68/TRV78/TRV78E/TRV88/TRV98/TRV98E
 COLOR EVF MODEL : CCD-TR818

3-7. MODE CONTROL BLOCK DIAGRAM () : Page No. shown in () indicates the page to refer on the schematic diagram.

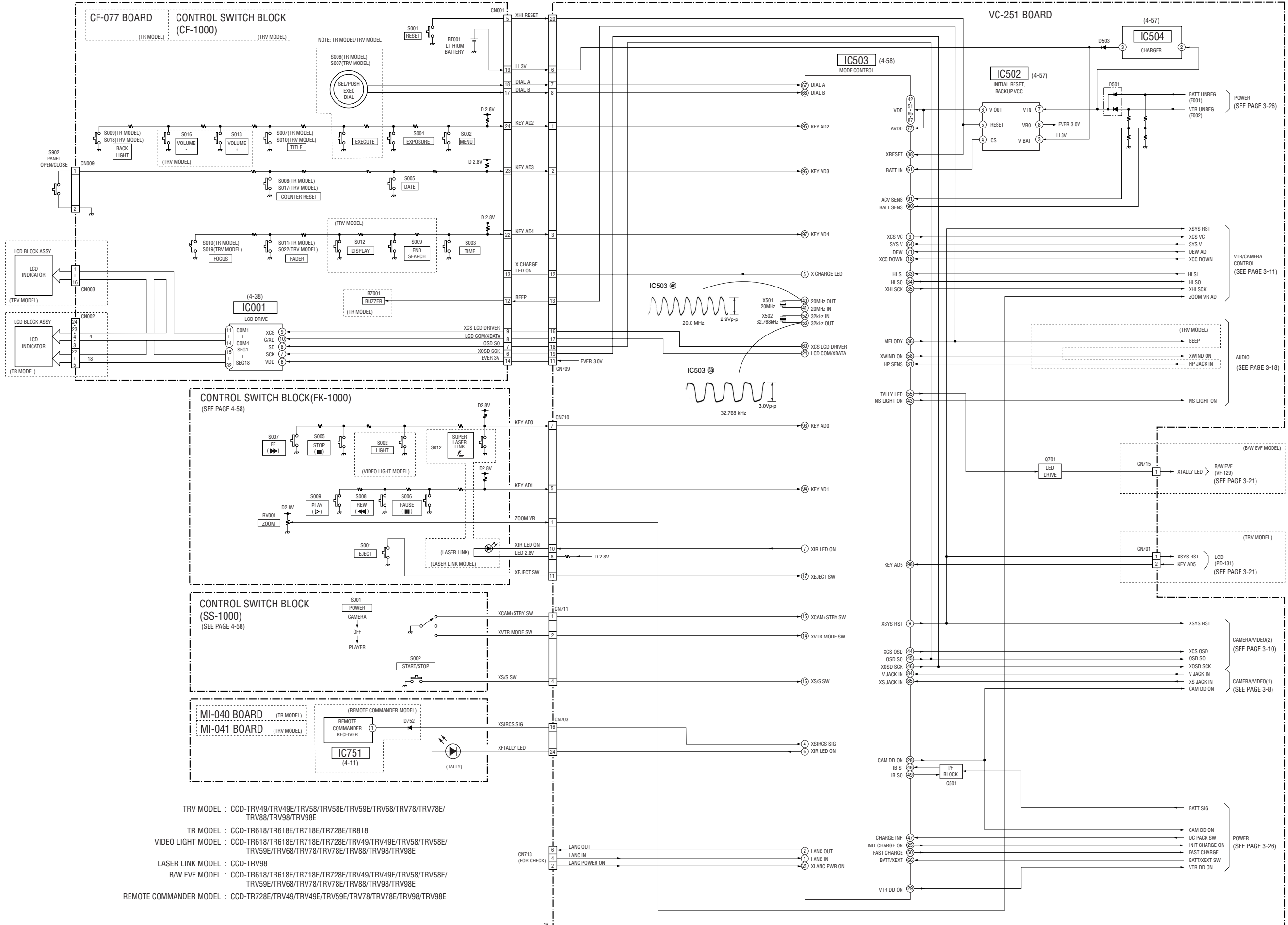

TRV MODEL : CCD-TRV49/TRV49E/TRV58/TRV58E/TRV59E/TRV68/TRV78/TRV78E/
TRV88/TRV98/TRV98E
TR MODEL : CCD-TR618/TR618E/TR718E/TR728E/TR818
VIDEO LIGHT MODEL : CCD-TR618/TR618E/TR718E/TR728E/TRV49/TRV49E/TRV58/TRV58E/
TRV59E/TRV68/TRV78/TRV78E/TRV88/TRV98/TRV98E
LASER LINK MODEL : CCD-TRV98
B/W EVF MODEL : CCD-TR618/TR618E/TR718E/TR728E/TRV49/TRV49E/TRV58/TRV58E/
TRV59E/TRV68/TRV78/TRV78E/TRV88/TRV98/TRV98E
REMOTE COMMANDER MODEL : CCD-TR728E/TRV49/TRV49E/TRV59E/TRV78/TRV78E/TRV98/TRV98E

3-9. LCD BLOCK DIAGRAM () : Page No. shown in () indicates the page to refer on the schematic diagram.

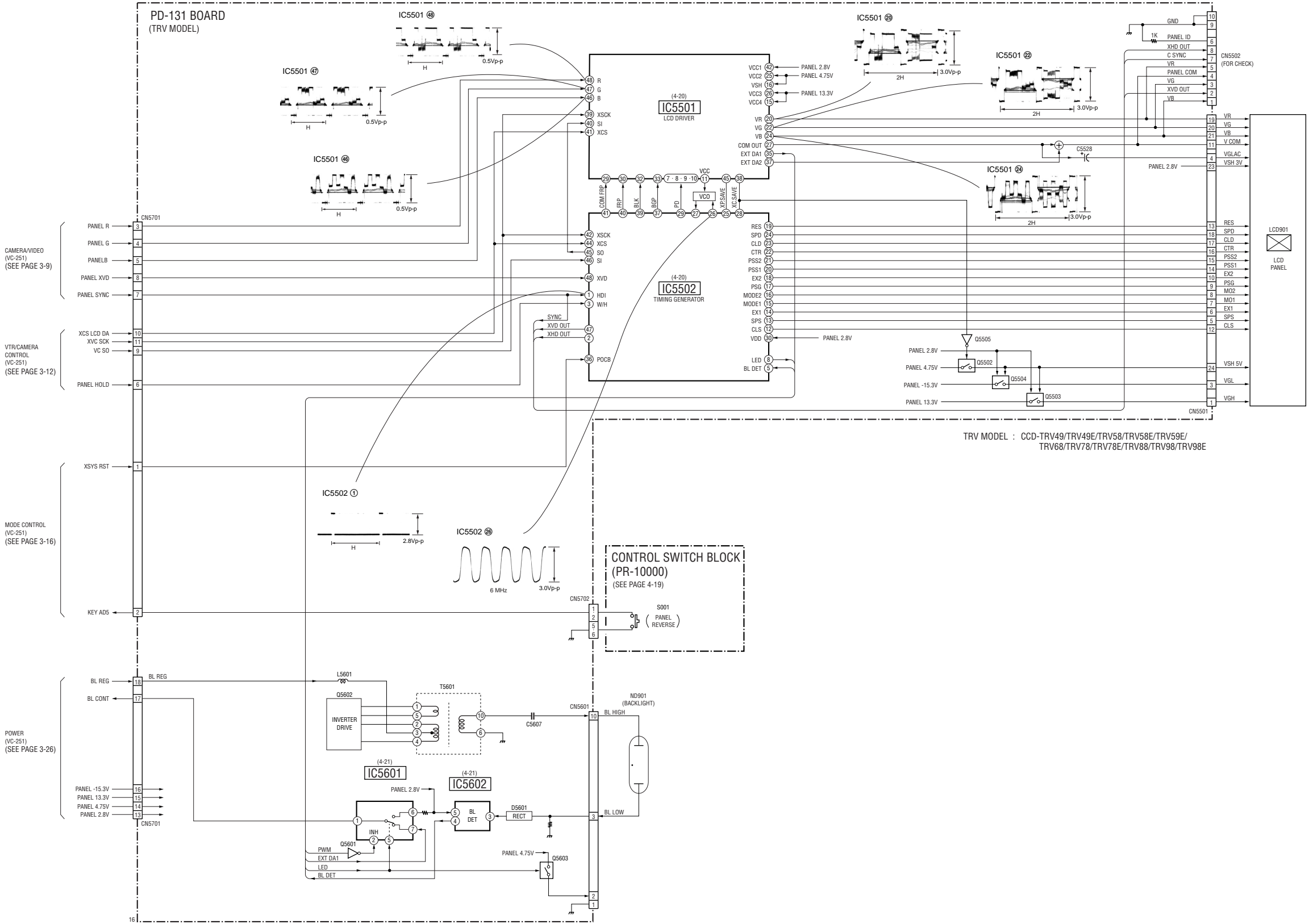

3-10. B/W EVF BLOCK DIAGRAM () : Page No. shown in () indicates the page to refer on the schematic diagram.

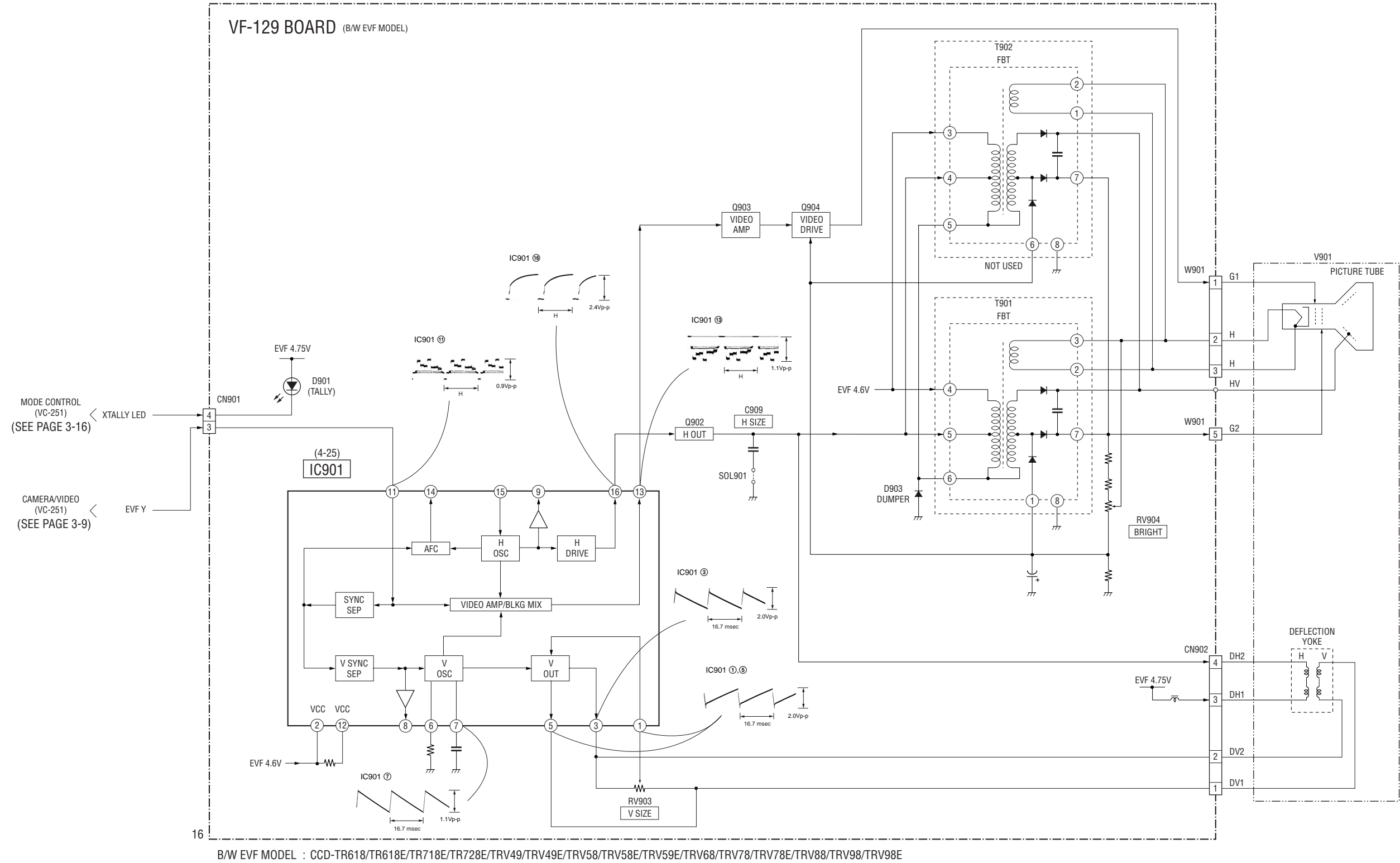

3-11.COLOR EVF BLOCK DIAGRAM () : Page No. shown in () indicates the page to refer on the schematic diagram.

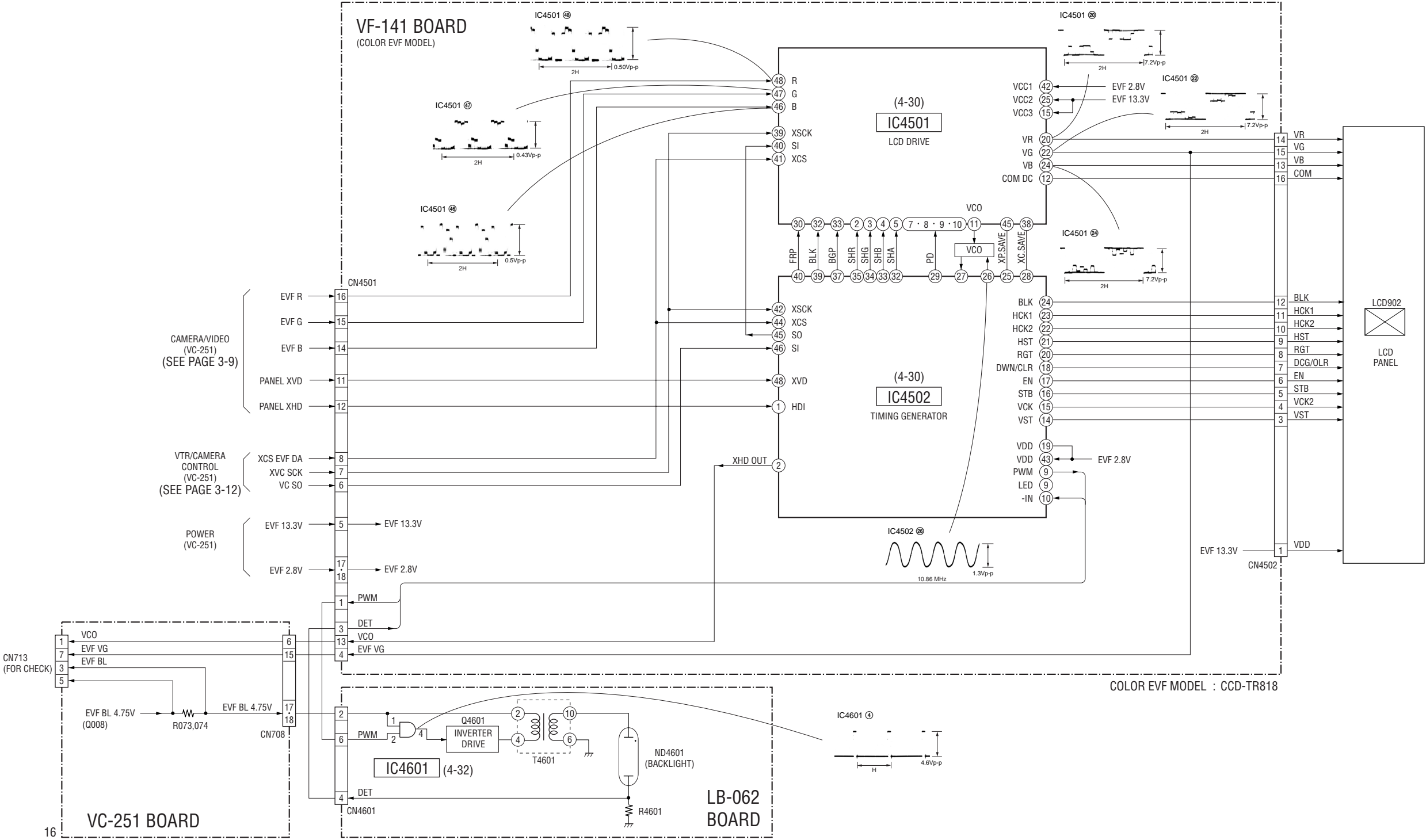

CCD-TR618/TR618E/TR718E/TR728E/TR818/TRV49/TRV49E/TRV58/
TRV58E/TRV59E/TRV68/TRV78/TRV78E/TRV88/TRV98/TRV98E

3-13. POWER BLOCK DIAGRAM (2/2) () : Page No. shown in () indicates the page to refer on the schematic diagram.

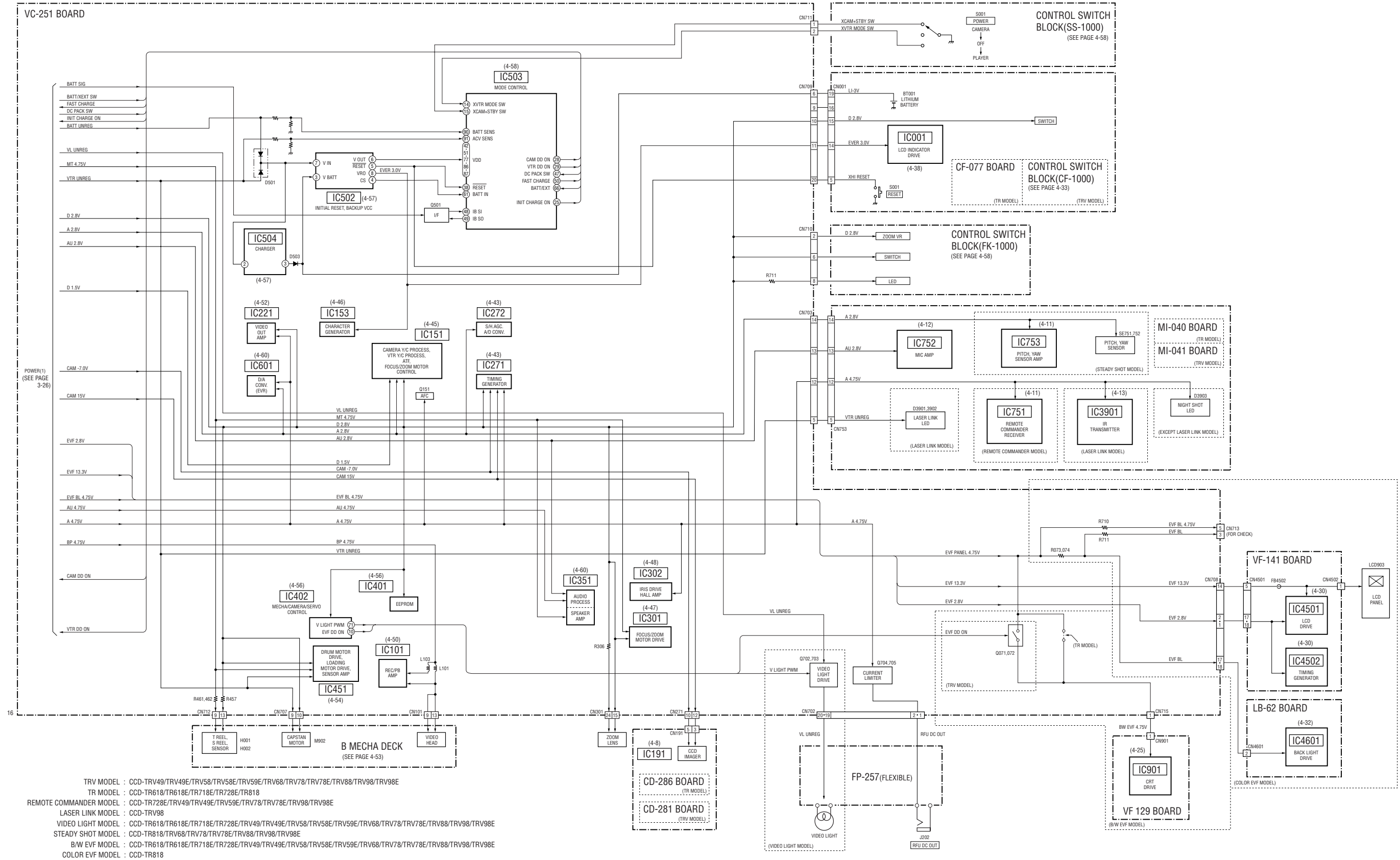

SECTION 4
PRINTED WIRING BOARDS AND SCHEMATIC DIAGRAMS

CCD-TR618/TR618E/TR718E/TR728E/TR818/TRV49/TRV49E/TRV58/
TRV58E/TRV59E/TRV68/TRV78/TRV78E/TRV88/TRV98/TRV98E

4-1. FRAME SCHEMATIC DIAGRAM (1/2)

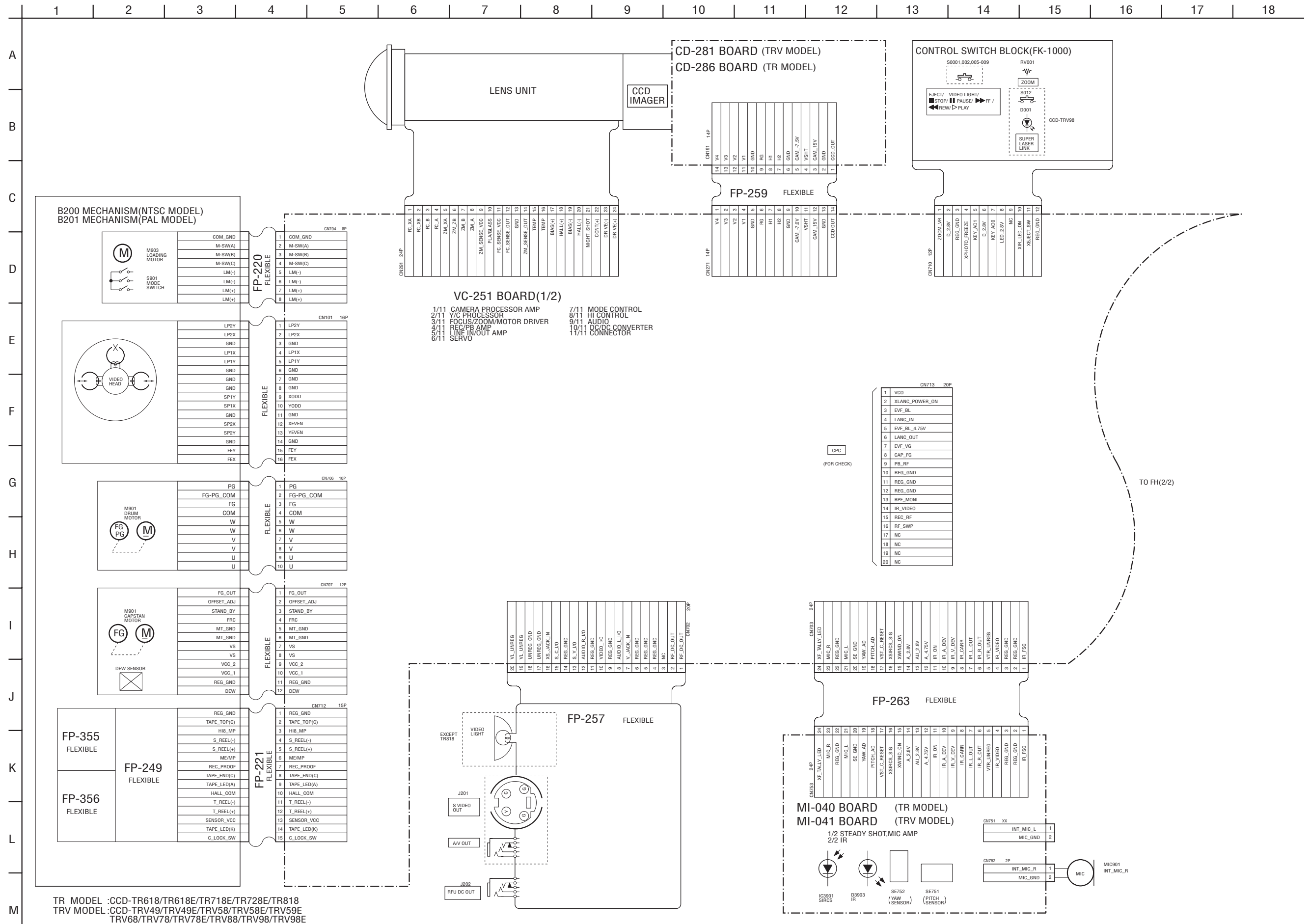

FRAME SCHEMATIC DIAGRAM (2/2)

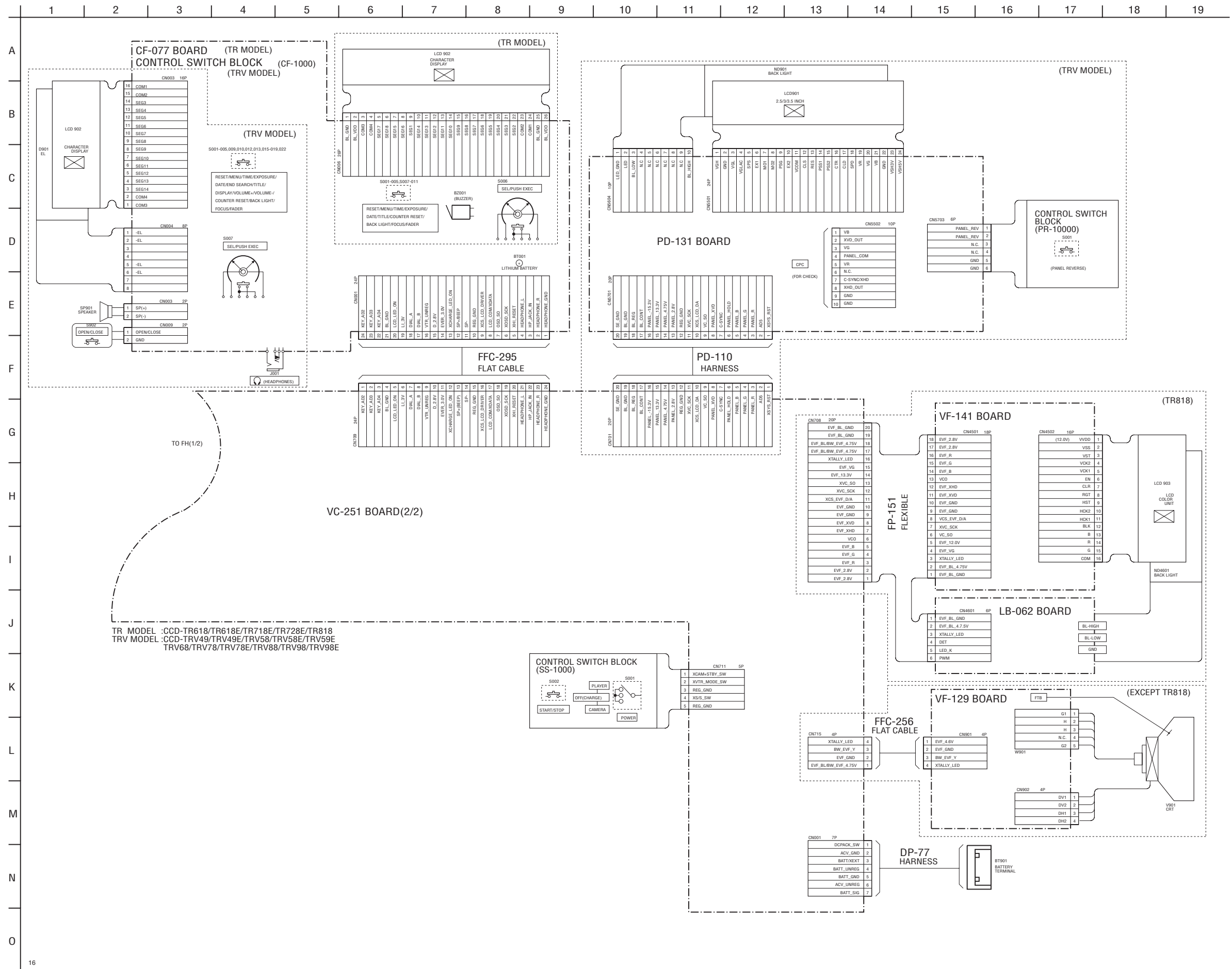

4-2. PRINTED WIRING BOARDS AND SCHEMATIC DIAGRAMS

THIS NOTE IS COMMON FOR WIRING BOARDS AND SCHEMATIC DIAGRAMS (In addition to this, the necessary note is printed in each block)

(For printed wiring boards)

- Pattern from the side which enables seeing.
(The other layers' patterns are not indicated.)
- Through hole is omitted.
- Circled numbers refer to waveforms.
- There are few cases that the part printed on diagram isn't mounted in this model.
- Chip parts.

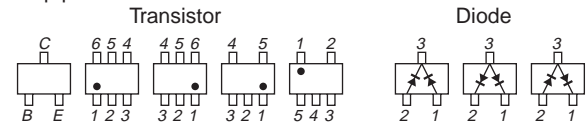

(For schematic diagrams)

- All capacitors are in mF unless otherwise noted. pF : mF. 50V or less are not indicated except for electrolytics and tantalums.
- Chip resistors are 1/10W unless otherwise noted. kW=1000W, MW=1000kW.
- Caution when replacing chip parts.
New parts must be attached after removal of chip.
Be careful not to heat the minus side of tantalum capacitor, Because it is damaged by the heat.
- Some chip part will be indicated as follows.

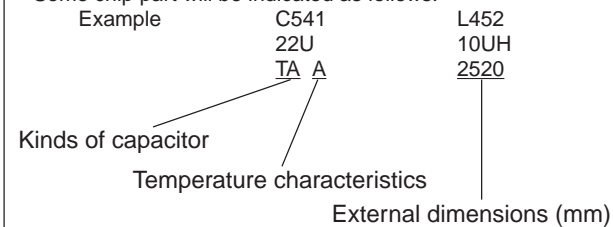

- Constants of resistors, capacitors, ICs and etc with XX indicate that they are not used.
In such cases, the unused circuits may be indicated.
- All variable and adjustable resistors have characteristic curve B, unless otherwise noted.
- Signal name
XEDIT → EDIT PB/XREC → PB/REC
- non flammable resistor
- fusible resistor
- panel designation
- B+ Line *
- B- Line *
- IN/OUT direction of (+,-) B LINE. *
- adjustment for repair. *
- Circled numbers refer to waveforms. *
- * Indicated by the color red.

Note :
The components identified by mark Δ or dotted line with mark Δ are critical for safety. Replace only with part number specified.

Note :
Les composants identifiés par une marque Δ sont critiques pour la sécurité. Ne les remplacer que par une pièce portant le numéro spécifié.

(Measuring conditions voltage and waveform)

- Voltages and waveforms are measured between the measurement points and ground when camera shoots color bar chart of pattern box. They are reference values and reference waveforms. *
- (VOM of DC 10 M Ω input impedance is used.).
- Voltage values change depending upon input impedance of VOM used.)*

1. Connection

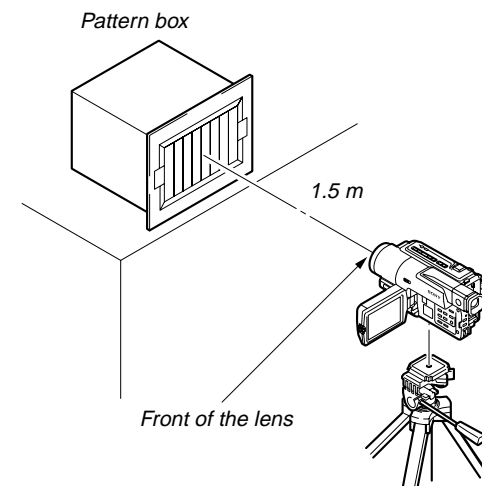

2. Adjust the distance so that the output waveform of Fig. a and the Fig. b can be obtain.

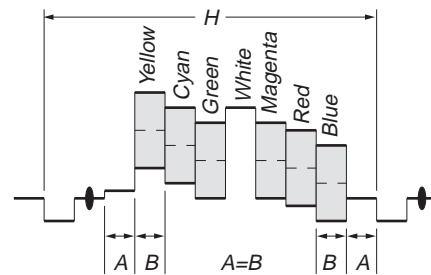

Fig. a (Video output terminal output waveform)

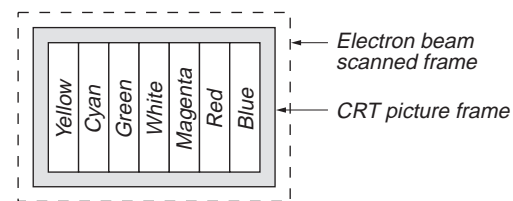
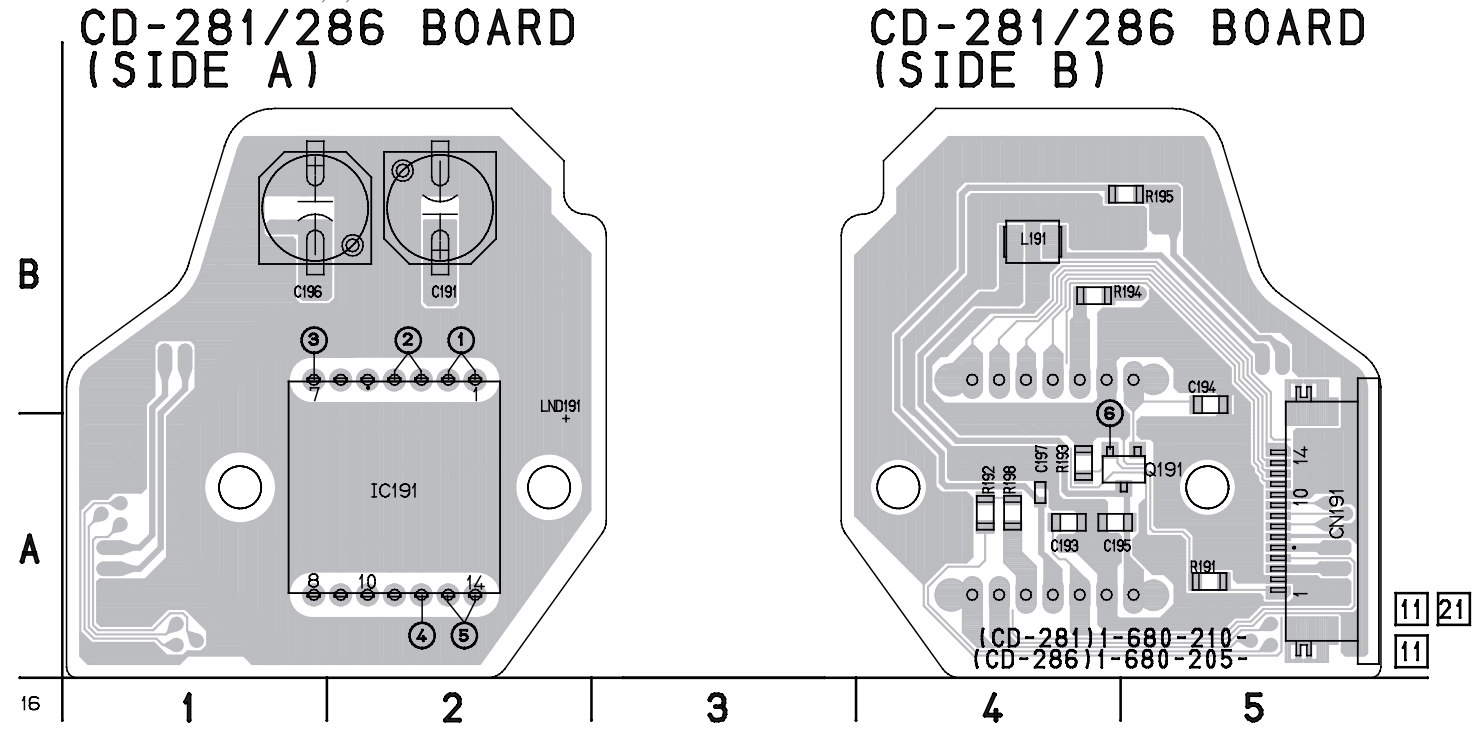

Fig. b (Picture on monitor TV)

When indicating parts by reference number, please include the board name.

CD-281/286 (CCD IMAGER) PRINTED WIRING BOARD

— Ref. No. CD-281/286 Board; 1,000 Series —



For printed wiring board

- Refer to page 4-70 for parts location.
- CD-281/286 board consists of multiple layers. However, only the sides (layers) A and B are shown.
- Chip parts

Transistor



There are a few cases that the part printed on this diagram isn't mounted in this model.

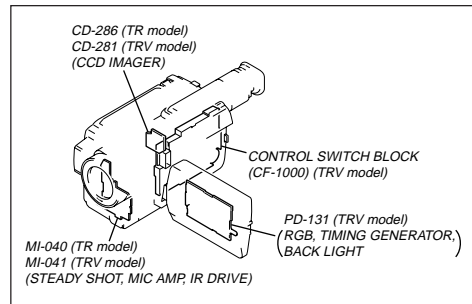

CD-281/286 BOARD (SIDE B)

For Schematic Diagram

• Refer to page 4-66 for waveforms.

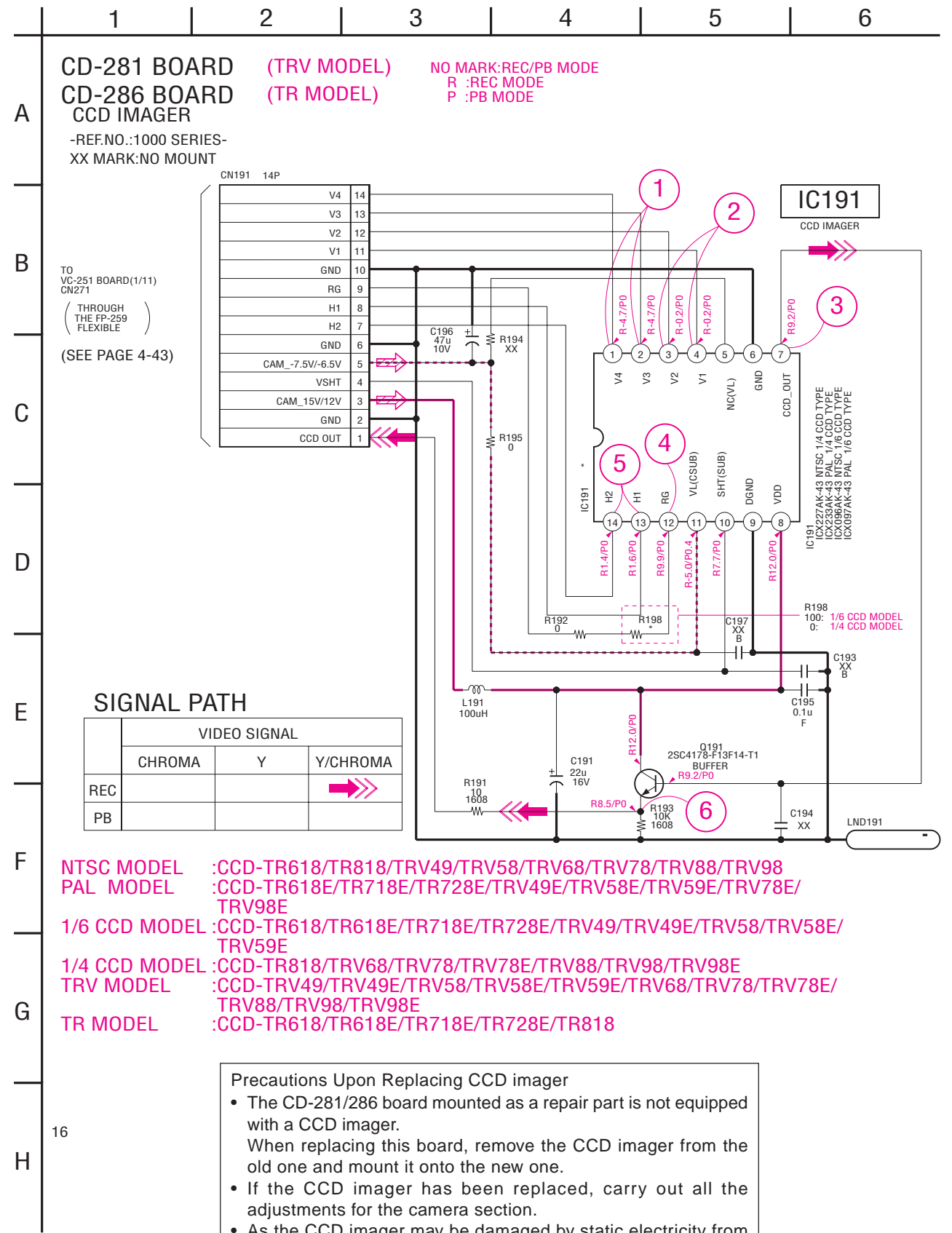

MI-040/041 (STEADY SHOT, MIC AMP, IR DRIVE) PRINTED WIRING BOARD
— Ref. No. MI-040/041 Board; 10,000 Series —
MI-040/041 BOARD (SIDE A)

MI-040/041 BOARD (SIDE B)

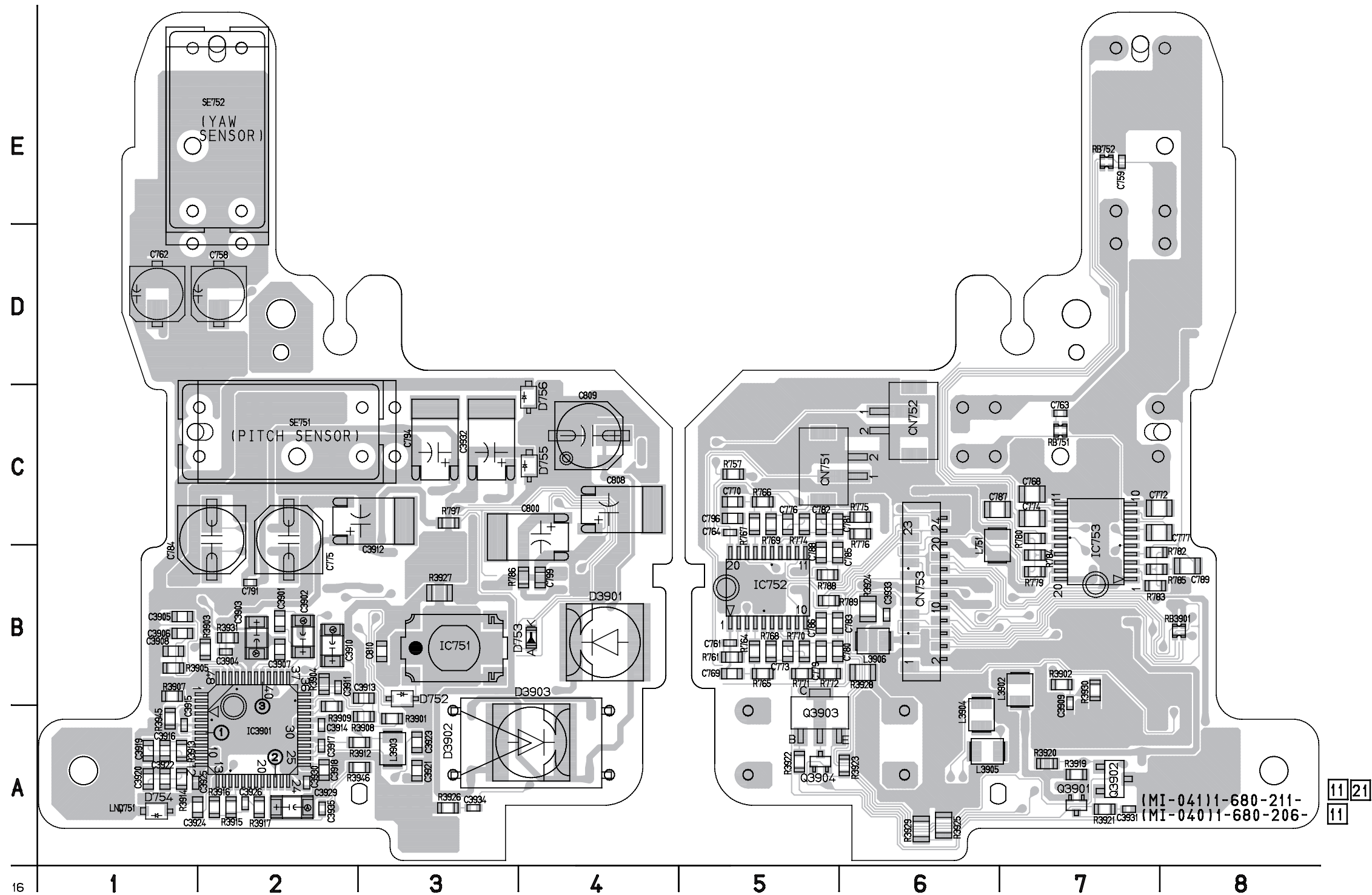

For printed wiring board

- Refer to page 4-70 for parts location.
- MI-040/041 board consists of multiple layers. However, only the sides (layers) A and B are shown.
- Chip parts

Transistor



There are a few cases that the part printed on this diagram isn't mounted in this model.

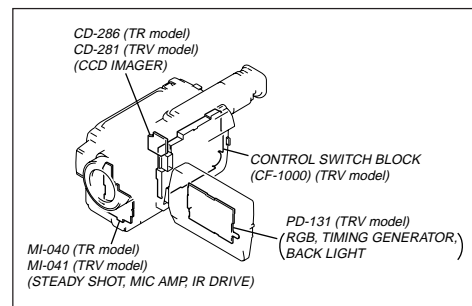

CCD-TR618/TR618E/TR718E/TR728E/TR818/TRV49/TRV49E/TRV58/
TRV58E/TRV59E/TRV68/TRV78/TRV78E/TRV88/TRV98/TRV98E

For Schematic Diagram
• Refer to page 4-9 for printed wiring board.

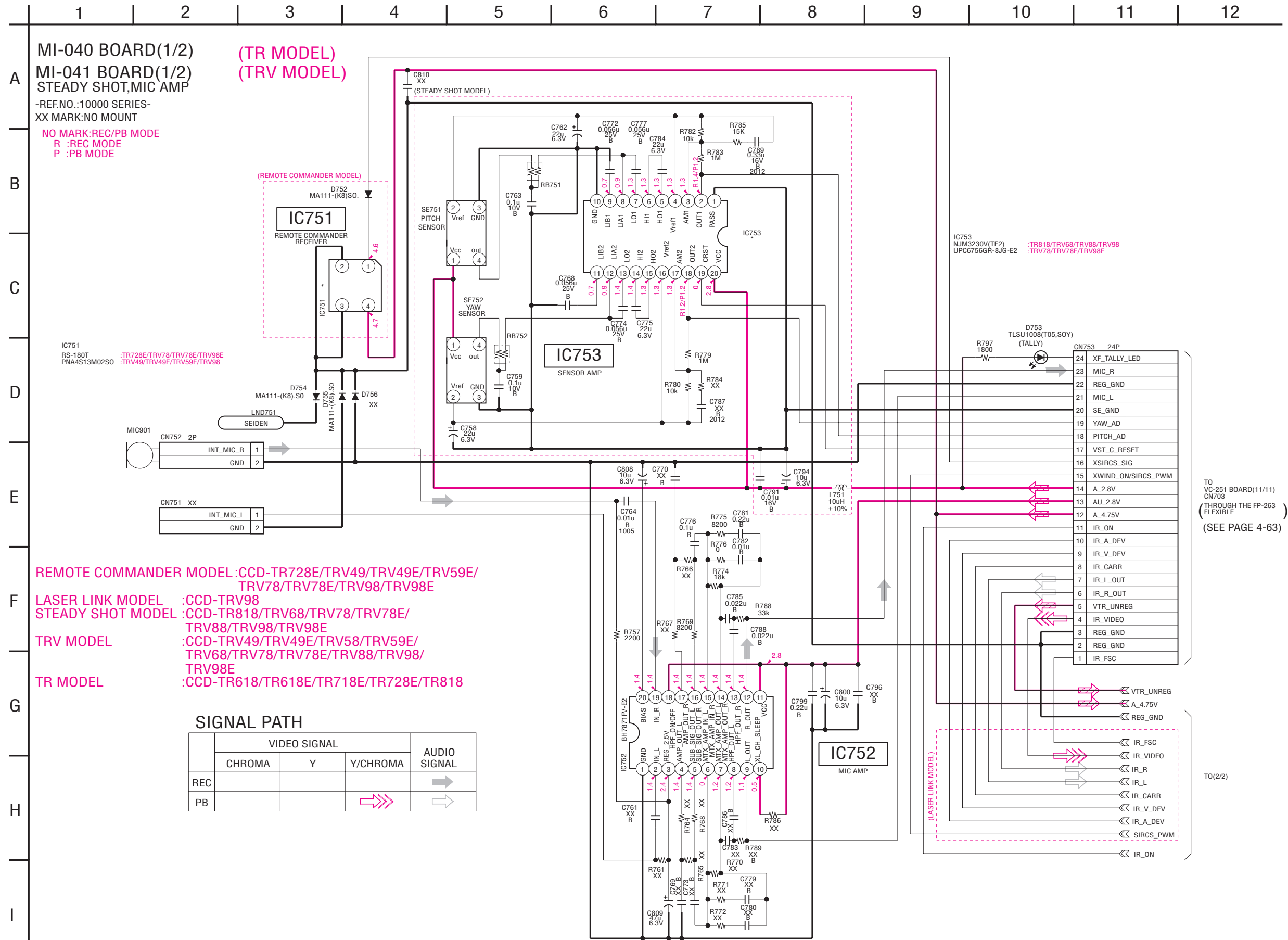

For Schematic Diagram

- Refer to page 4-9 for printed wiring board.
- Refer to page 4-66 for waveforms.

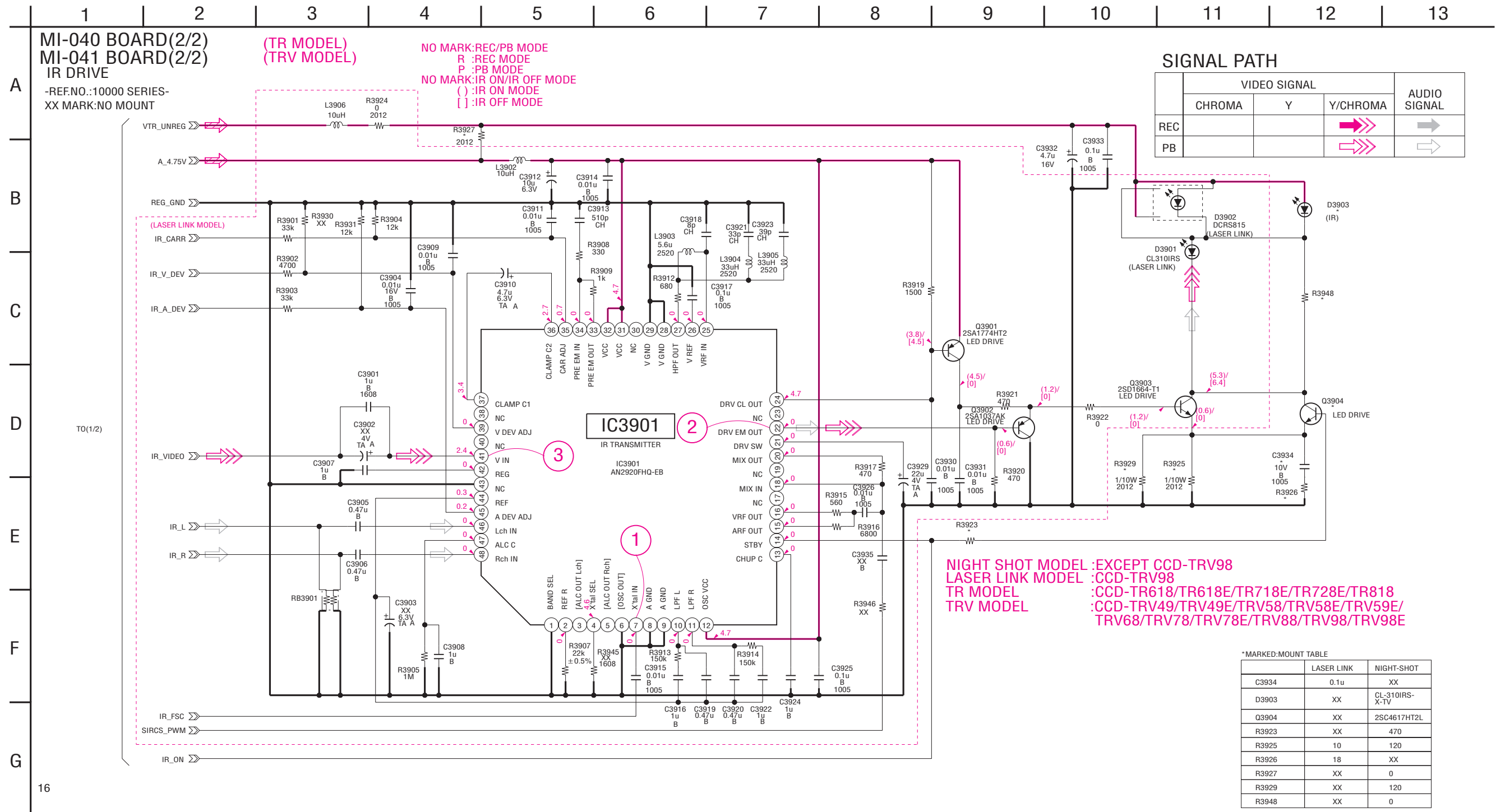

PD-131 (RGB, TIMING GENERATOR, BACK LIGHT) PRINTED WIRING BOARD
— Ref. No. PD-131 Board; 10,000 Series —

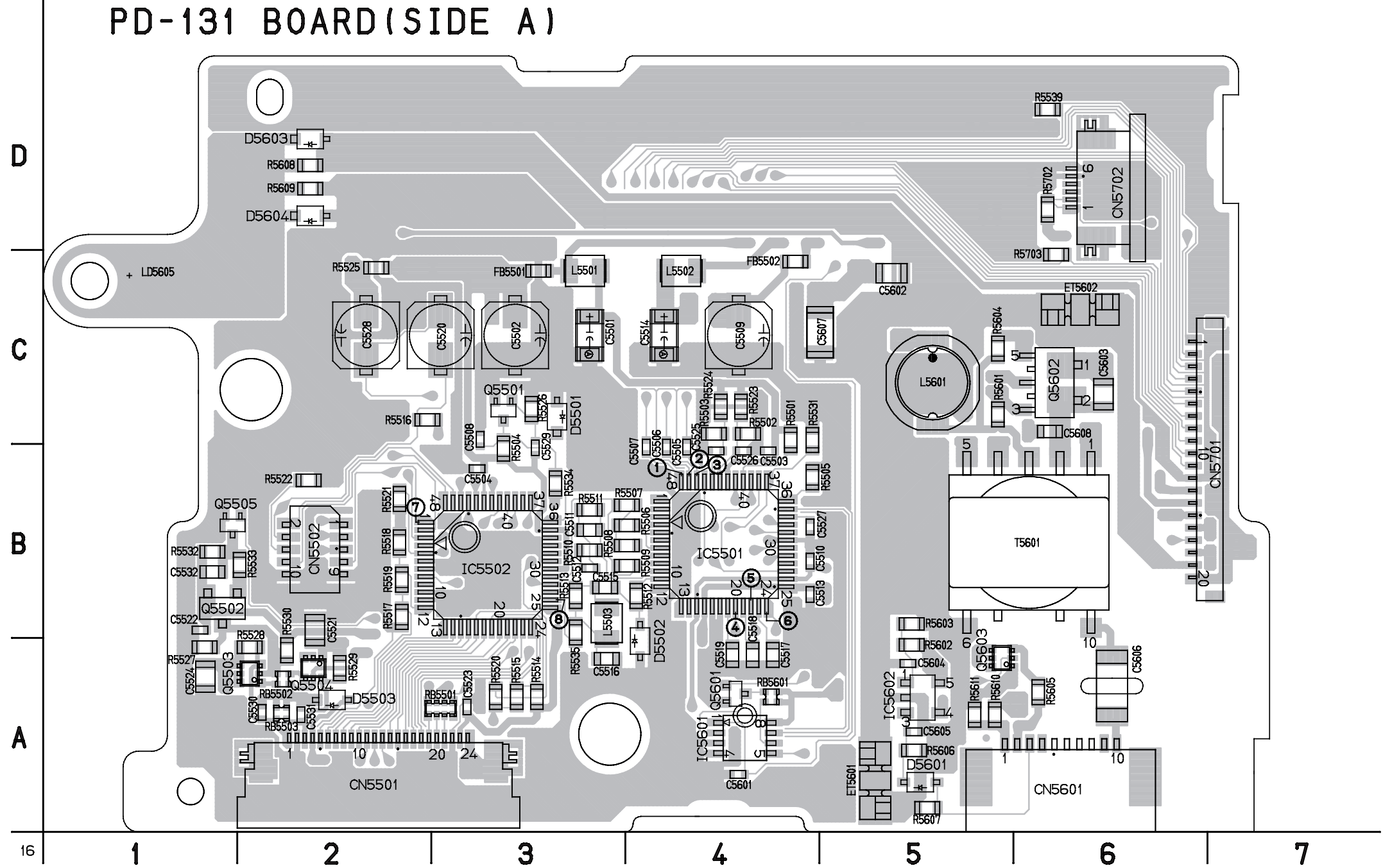

For printed wiring board

- Refer to page 4-70 for parts location.
- PD-131 board consists of multiple layers. However, only the sides (layers) A and B are shown.
- Chip parts

Transistor



There are a few cases that the part printed on this diagram isn't mounted in this model.

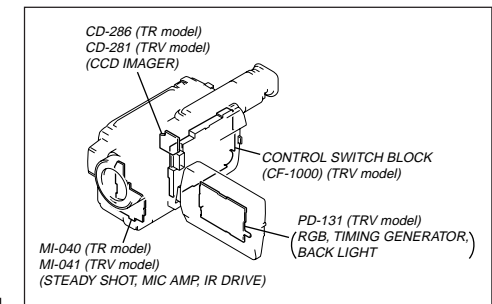

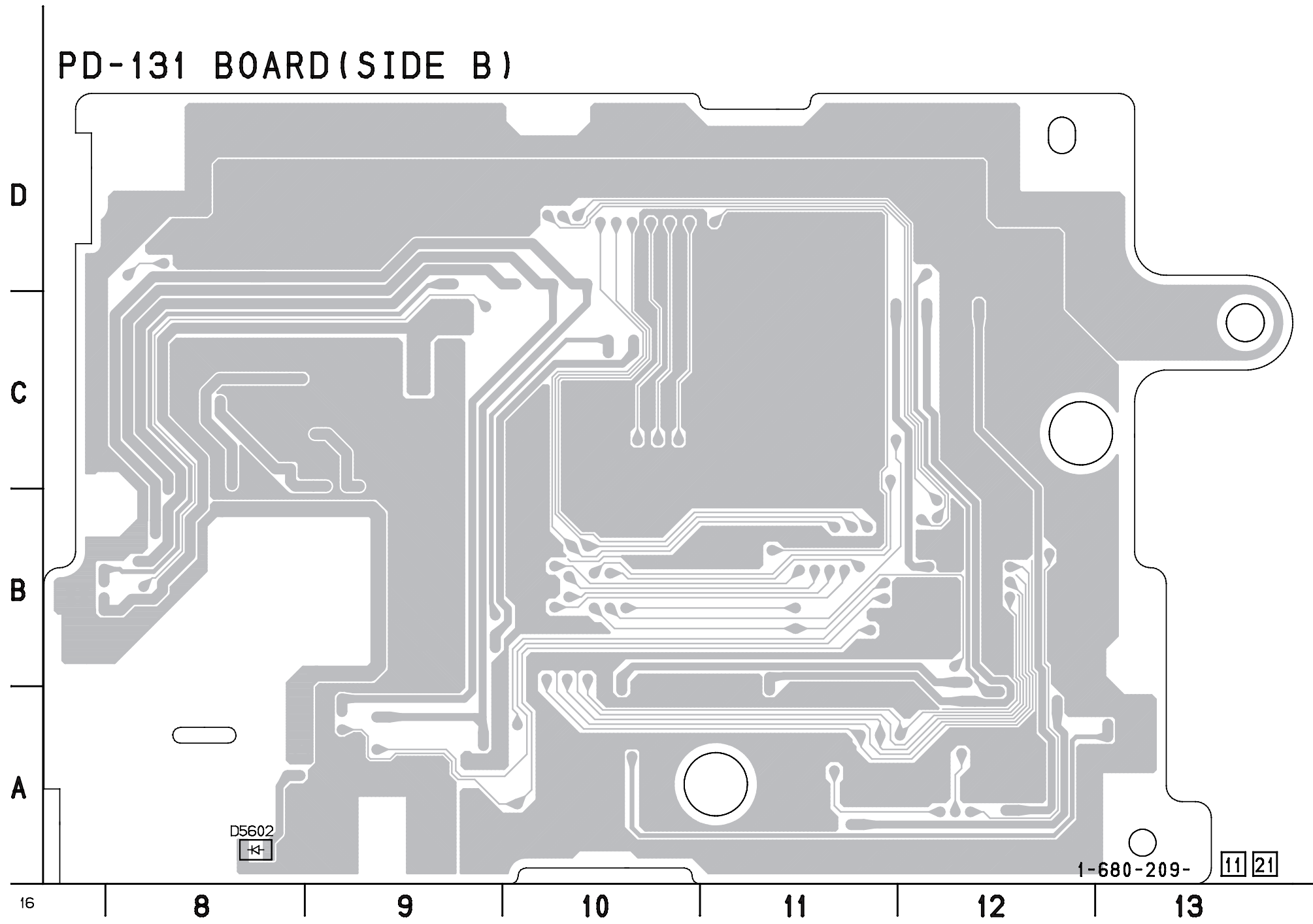

**CCD-TR618/TR618E/TR718E/TR728E/TR818/TRV49/TRV49E/TRV58/
TRV58E/TRV59E/TRV68/TRV78/TRV78E/TRV88/TRV98/TRV98E**

For Schematic Diagram

- Refer to page 4-15 for printed wiring board.
- Refer to page 4-66 for waveforms.

1 2 3 4 5 6 7 8 9 10 11 12 13 14 15 16 17 18 19 20

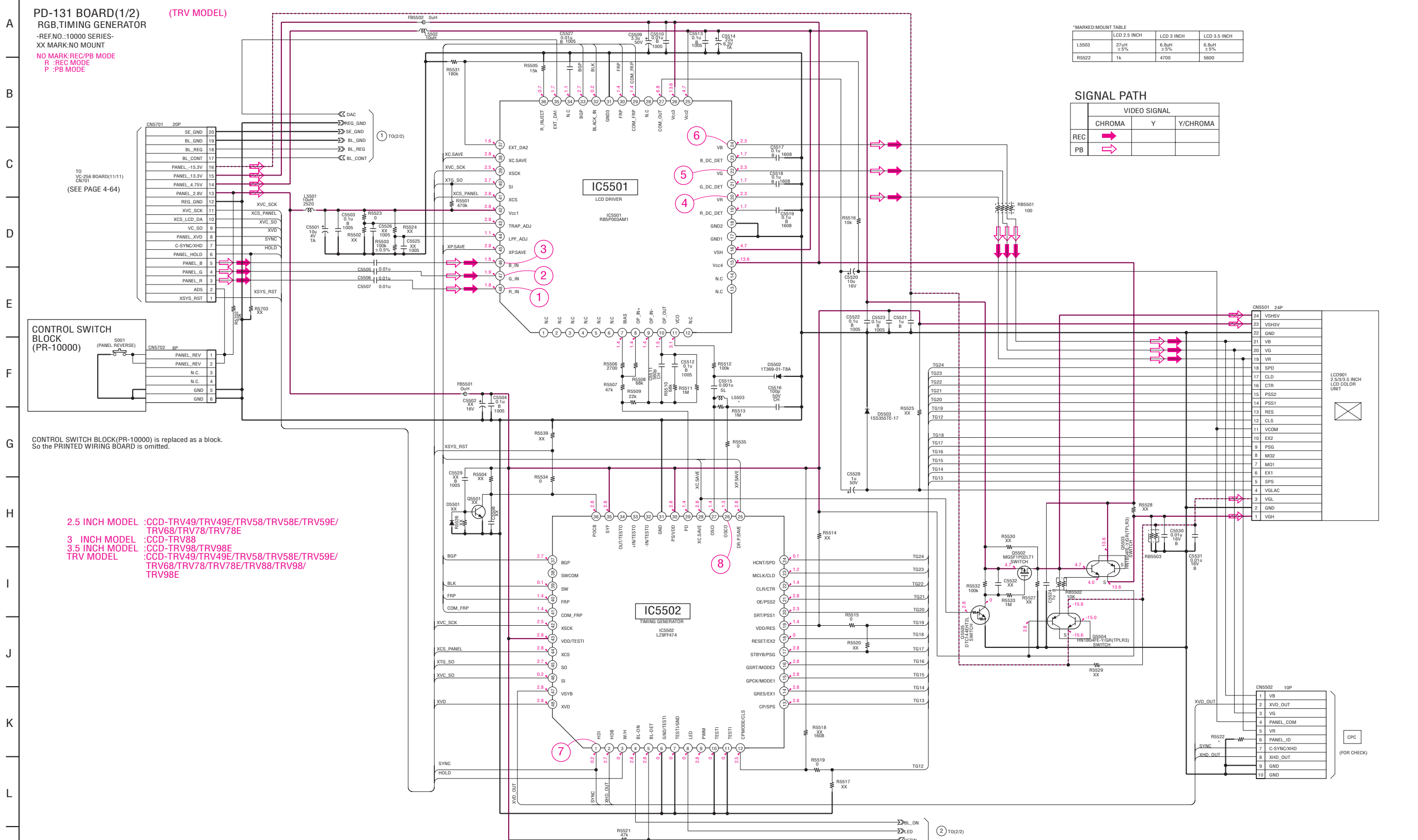

*MARKED-MOUNT TABLE

	LCD 2.5 INCH	LCD 3 INCH	LCD 3.5 INCH
L5503	27µH ±5%	6.8µH ±5%	6.8µH ±5%
R5522	1k	4700	5600

SIGNAL PATH

	VIDEO SIGNAL		
	CHROMA	Y	Y/CHROMA
REC	→		
PB	→		

PD-131 BOARD(1/2) (TRV MODEL)
 RGB, TIMING GENERATOR
 -REF.NO.:10000 SERIES-
 XX MARK:NO MOUNT
 NO MARK:REC/PB MODE
 R : REC MODE
 P : PB MODE

TO VC-256 BOARD(11/11) CN701 (SEE PAGE 4-64)

CONTROL SWITCH BLOCK (PR-10000)
 (PANEL REVERSE)

CONTROL SWITCH BLOCK(PR-10000) is replaced as a block. So the PRINTED WIRING BOARD is omitted.

2.5 INCH MODEL :CCD-TRV49/TRV49E/TRV58/TRV59E/
 TRV68/TRV78/TRV78E
 3 INCH MODEL :CCD-TRV88
 3.5 INCH MODEL :CCD-TRV98/TRV98E
 TRV MODEL :CCD-TRV49/TRV49E/TRV58/TRV58E/TRV59E/
 TRV68/TRV78/TRV78E/TRV88/TRV98/
 TRV98E

For Schematic Diagram

• Refer to page 4-15 for printed wiring board.

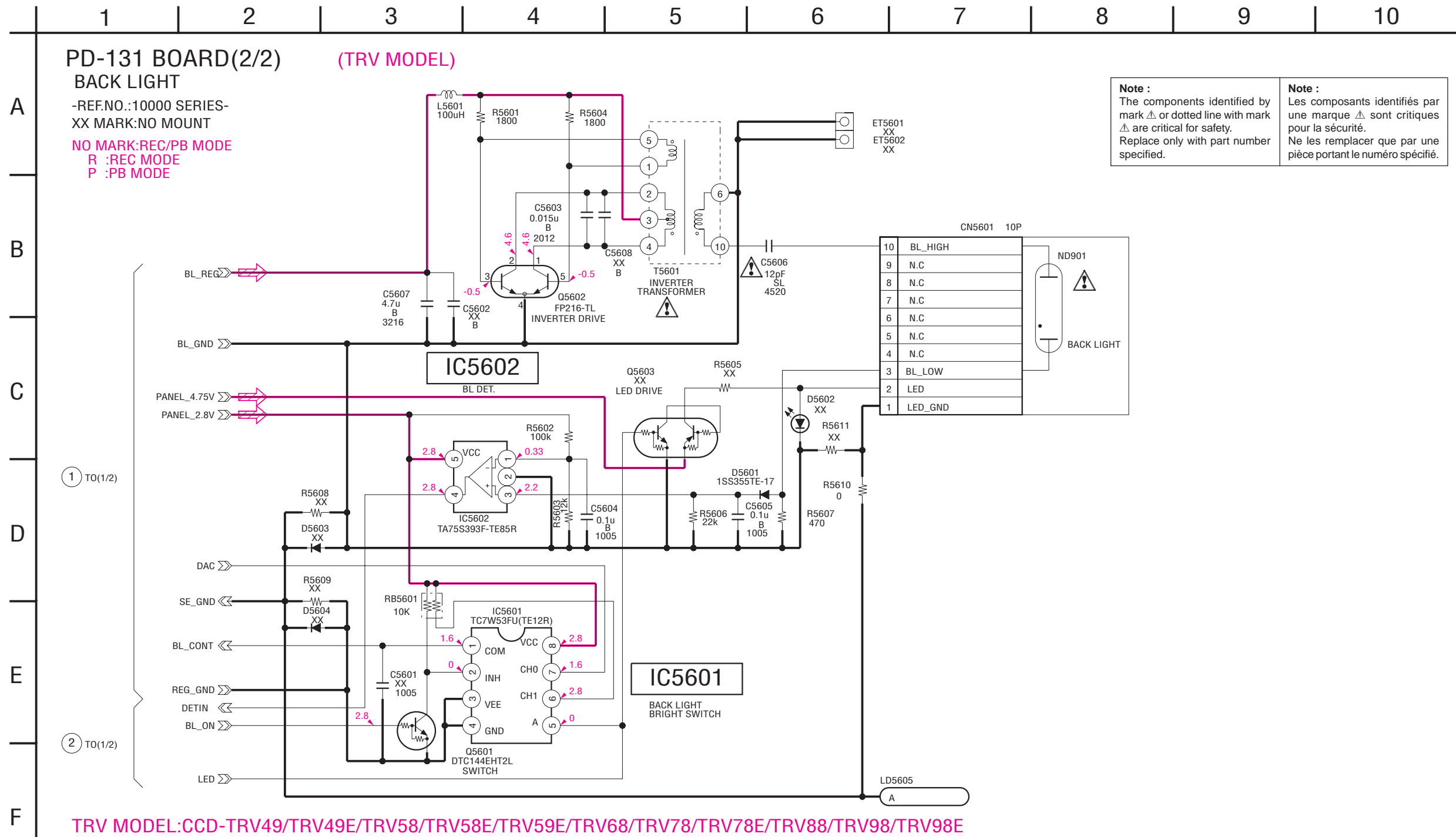

VF-129 (B/W EVF) PRINTED WIRING BOARD

— Ref. No. VF-129 Board; 1,000 Series —

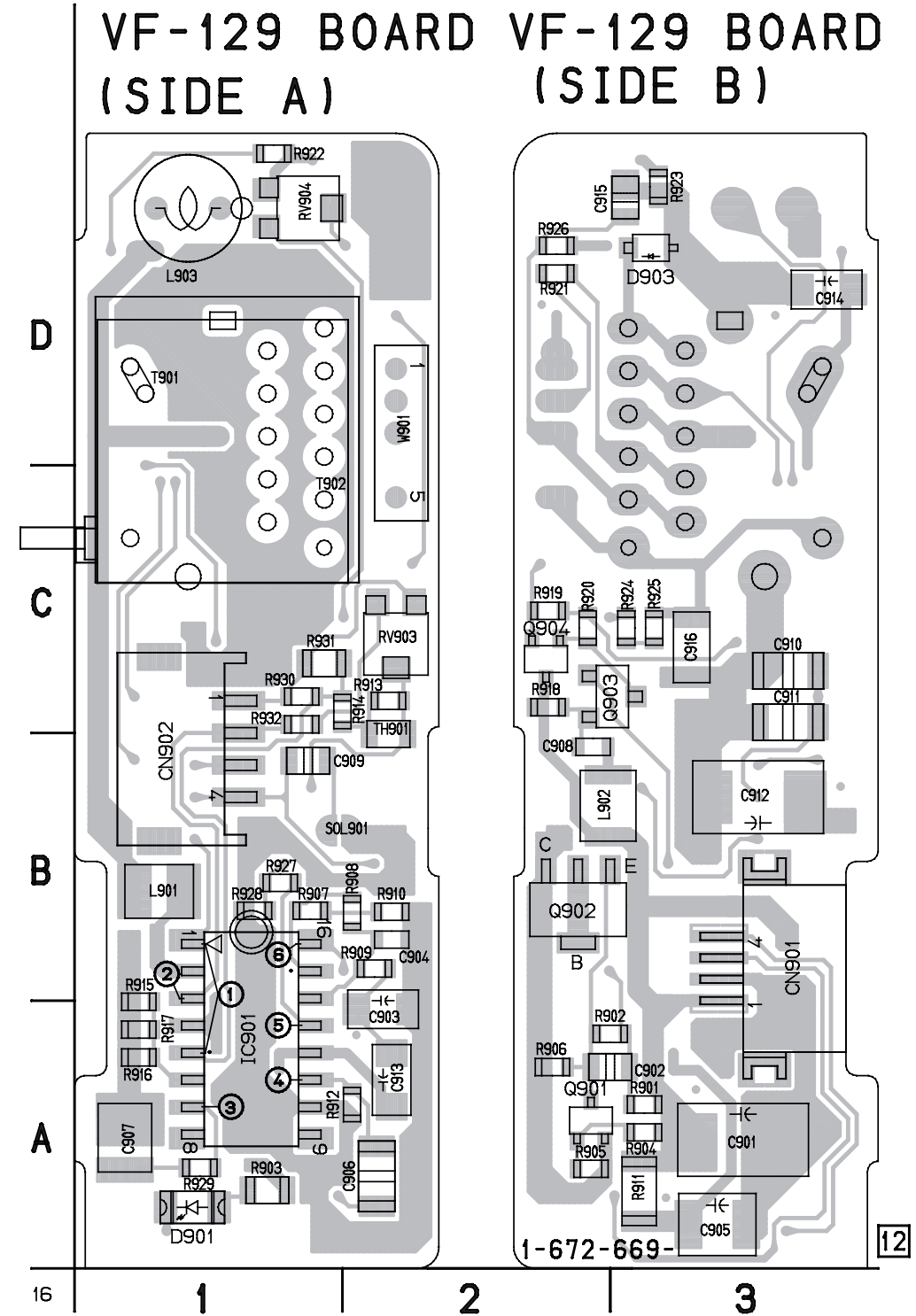

For printed wiring board

- Refer to page 4-71 for parts location.
- VF-129 board consists of multiple layers. However, only the sides (layers) A and B are shown.
- Chip parts

Transistor



There are a few cases that the part printed on this diagram isn't mounted in this model.

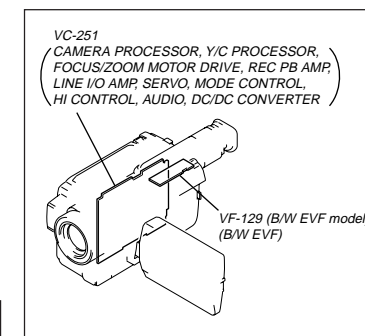

For Schematic Diagram
• Refer to page 4-66 for waveforms.

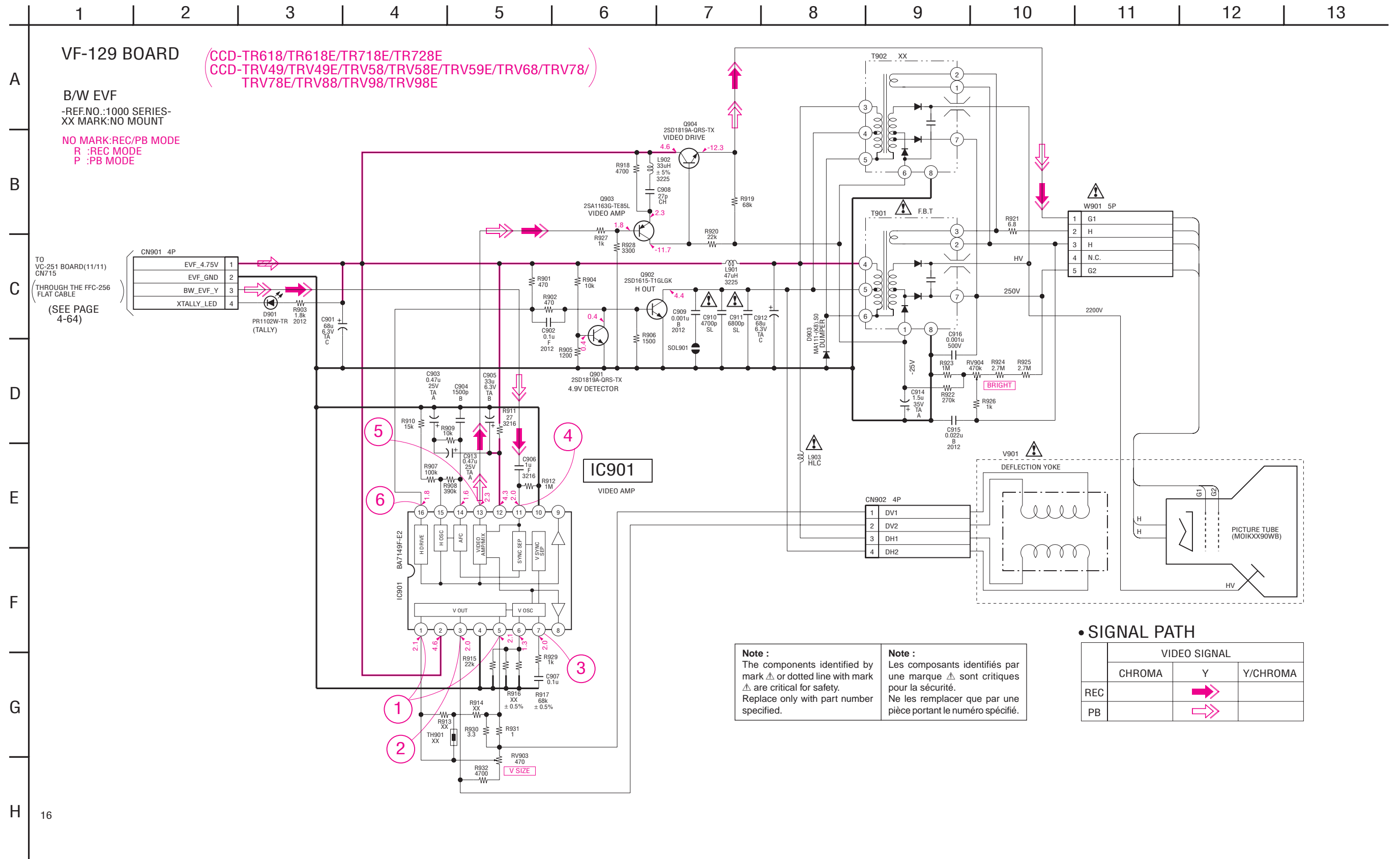

• SIGNAL PATH

	VIDEO SIGNAL		
	CHROMA	Y	Y/CHROMA
REC		➡	
PB		➡	

VF-141 (COLOR EVF) PRINTED WIRING BOARD

— Ref. No. VF-141 Board; 10,000 Series —

VF-141 BOARD (SIDE A)

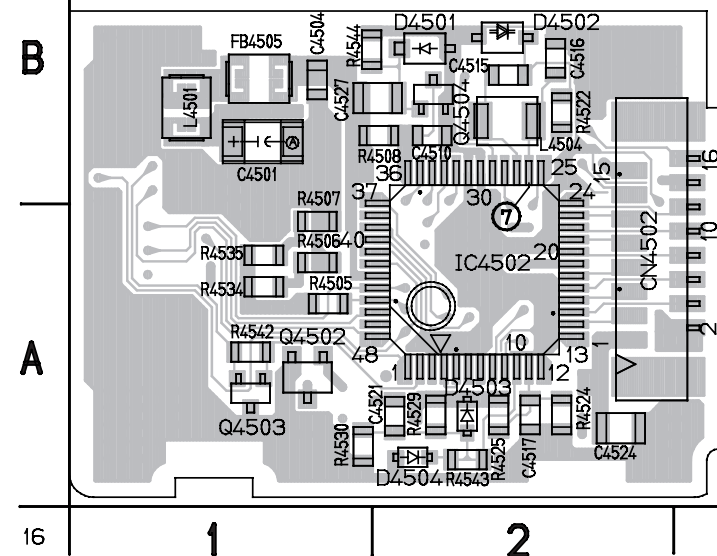

VF-141 BOARD (SIDE B)

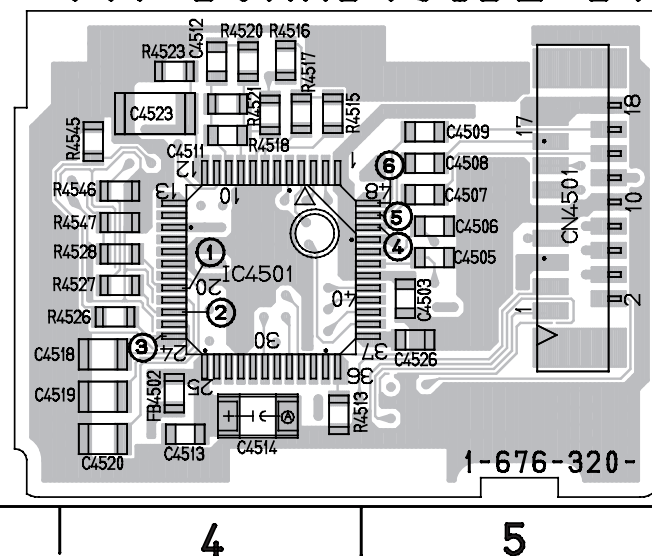

For printed wiring board

- Refer to page 4-71 for parts location.
- VF-141 board consists of multiple layers. However, only the sides (layers) A and B are shown.
- Chip parts

Transistor



There are a few cases that the part printed on this diagram isn't mounted in this model.

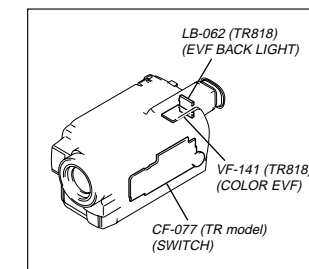

For Schematic Diagram

- Refer to page 4-27 for printed wiring board.
- Refer to page 4-67 for waveforms.

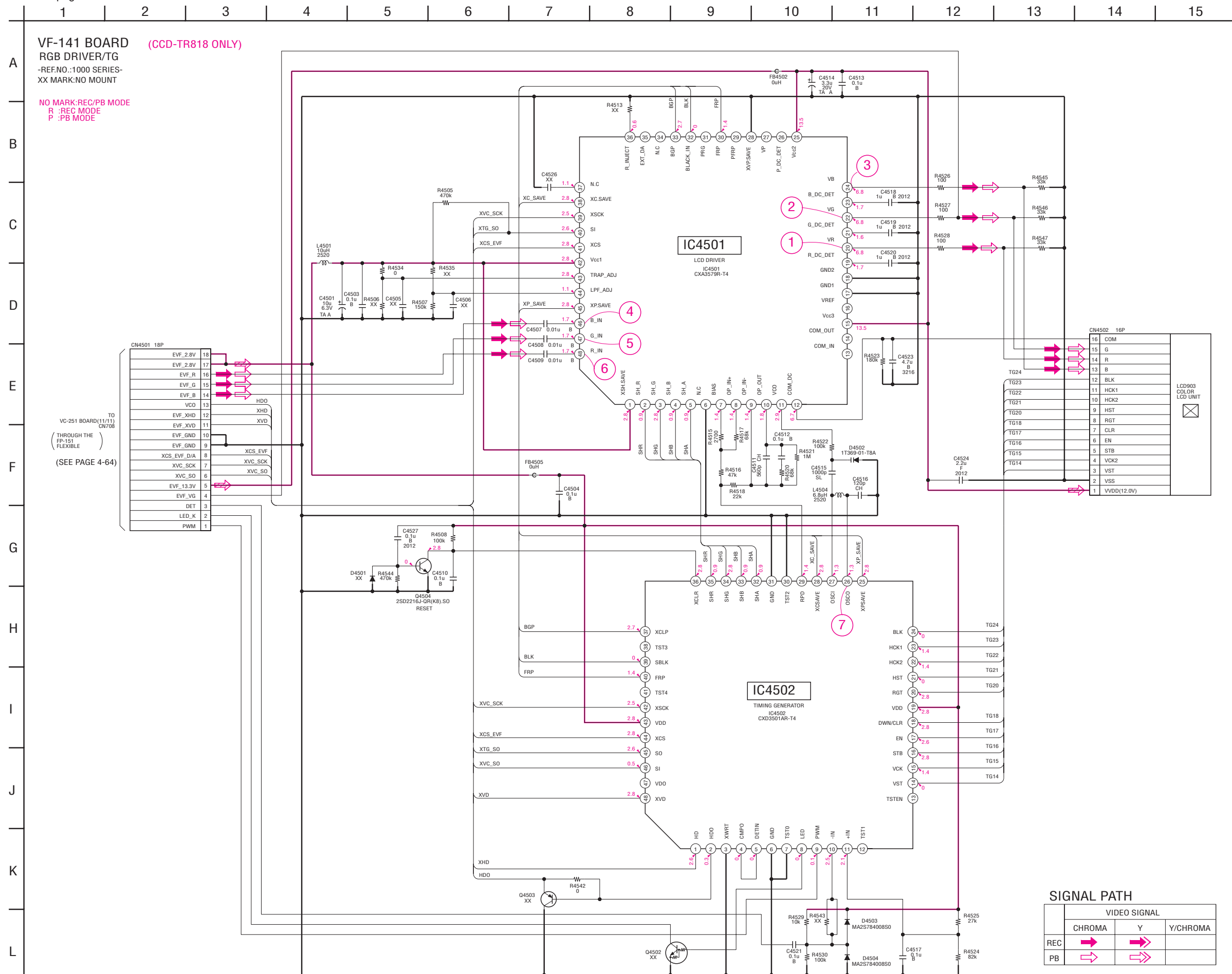

LB-062 (EVF BACK LIGHT) PRINTED WIRING BOARD

— Ref. No. LB-062 Board; 10,000 Series —

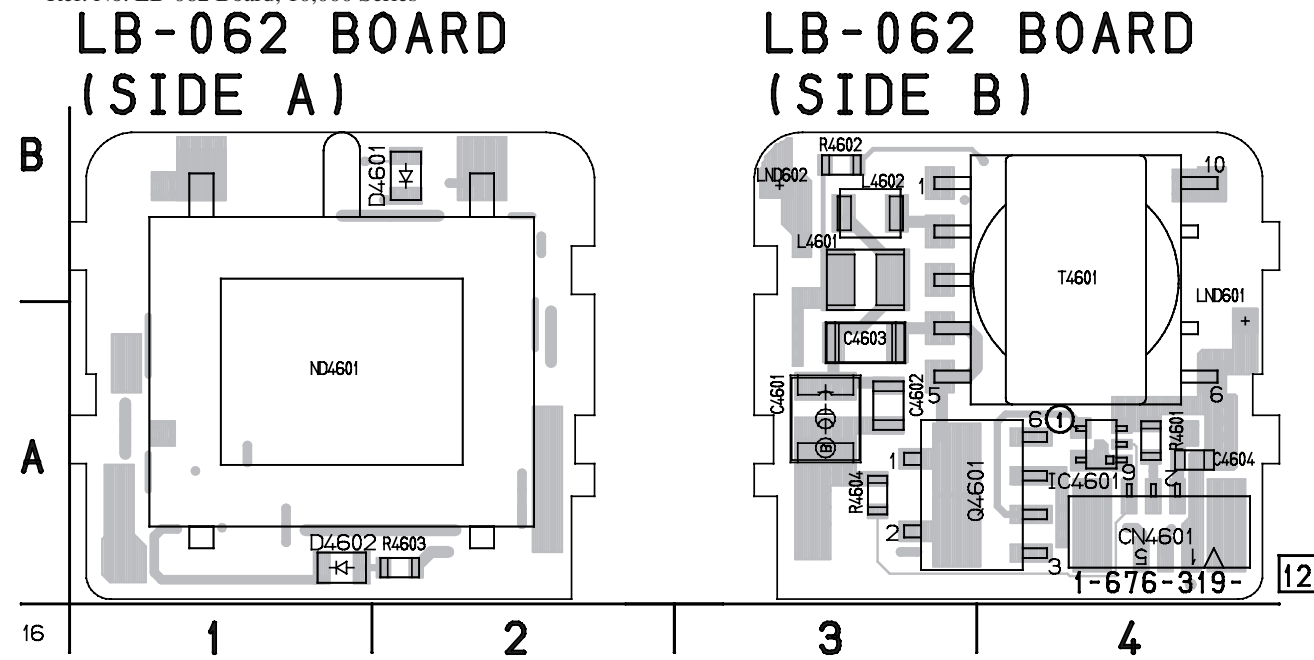

For printed wiring board

- Refer to page 4-71 for parts location.
- LB-062 board consists of multiple layers. However, only the sides (layers) A and B are shown.

There are a few cases that the part printed on this diagram isn't mounted in this model.

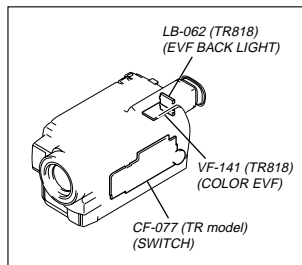

For Schematic Diagram

• Refer to page 4-67 for waveform.

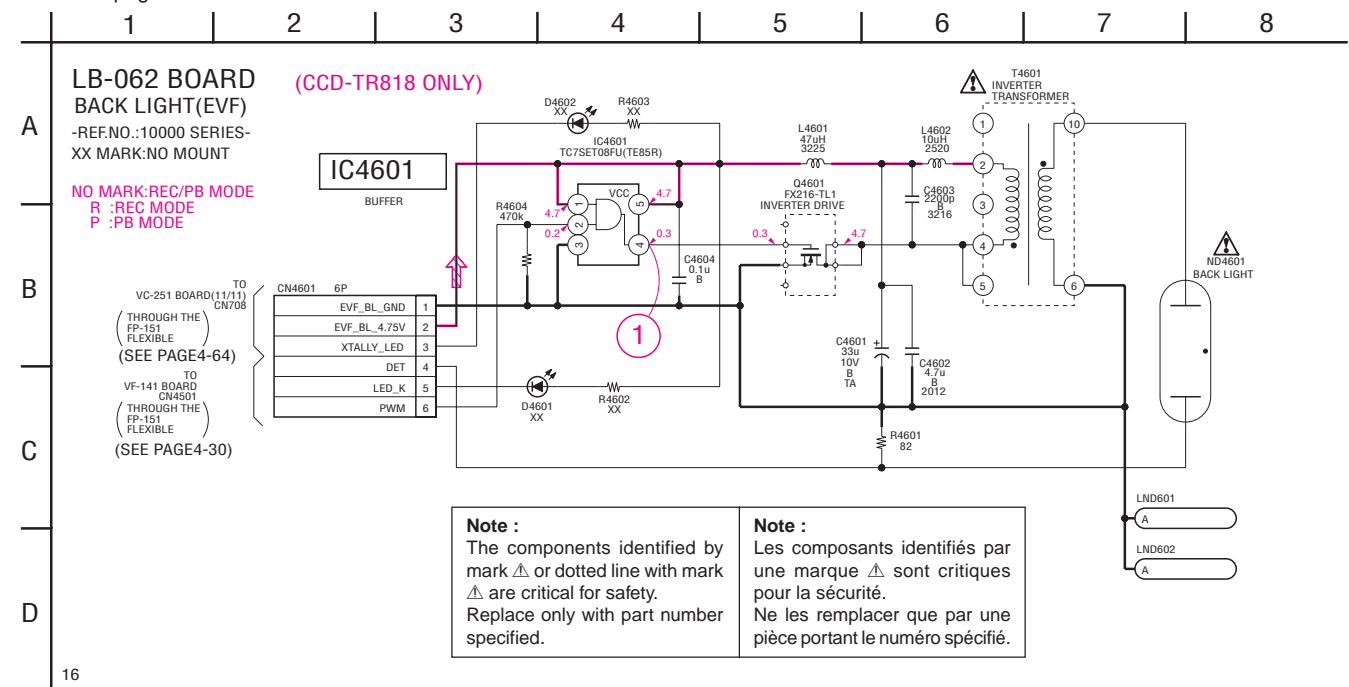

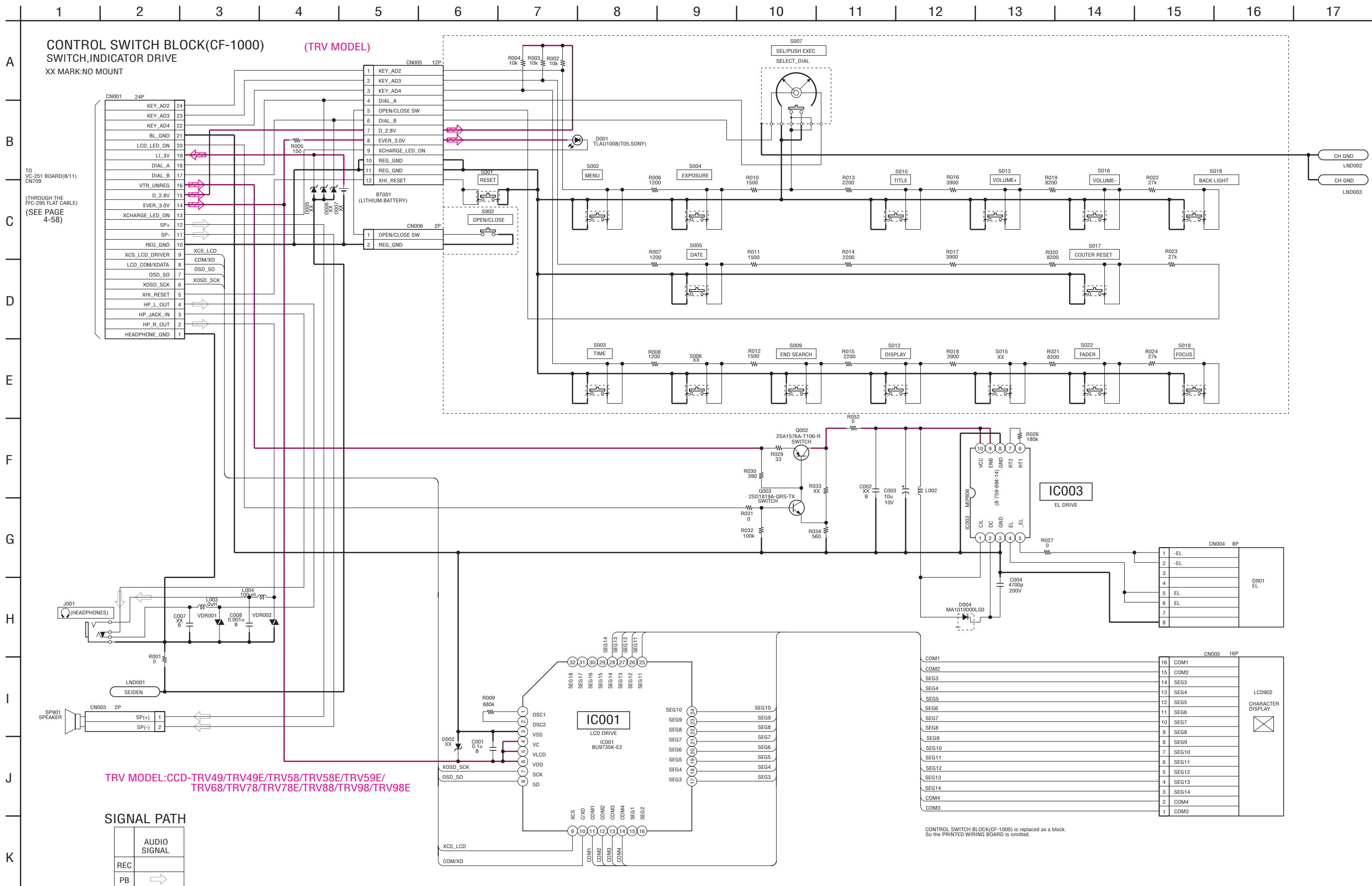

CF-077 (SWITCH) PRINTED WIRING BOARD
— Ref. No. CF-077 Board: 1,000 Series —
CF-077 BOARD (SIDE A)

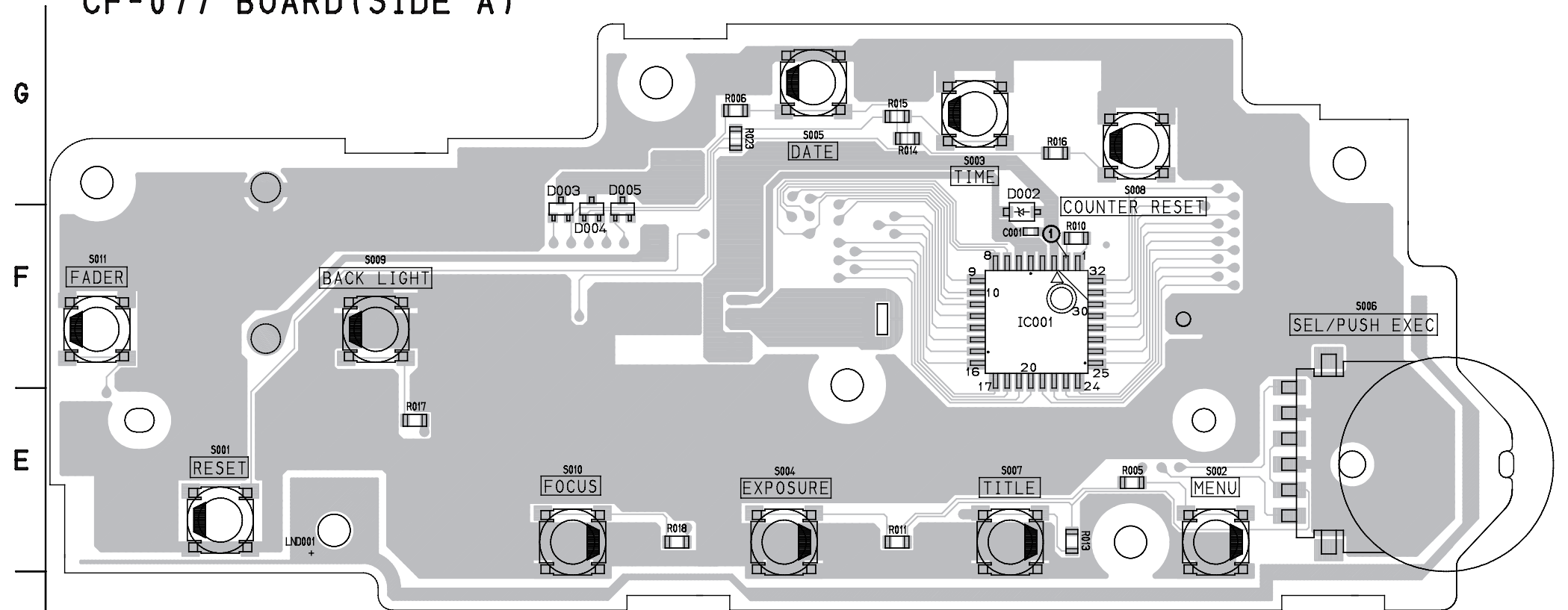

CF-077 BOARD (SIDE B)

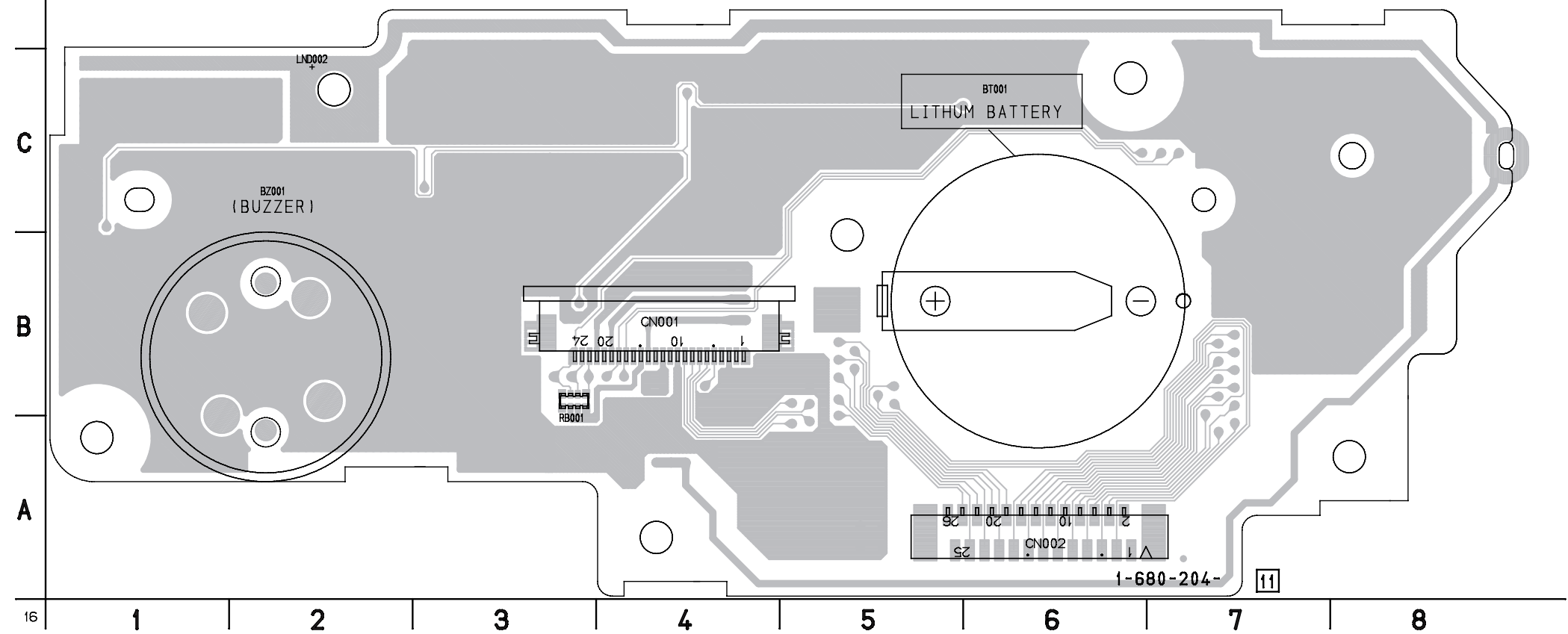

For printed wiring board

- Refer to page 4-71 for parts location.
- CF-077 board consists of multiple layers. However, only the sides (layers) A and B are shown.

There are a few cases that the part printed on this diagram isn't mounted in this model.

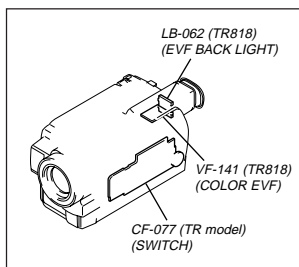

For Schematic Diagram

• Refer to page 4-67 for waveform.

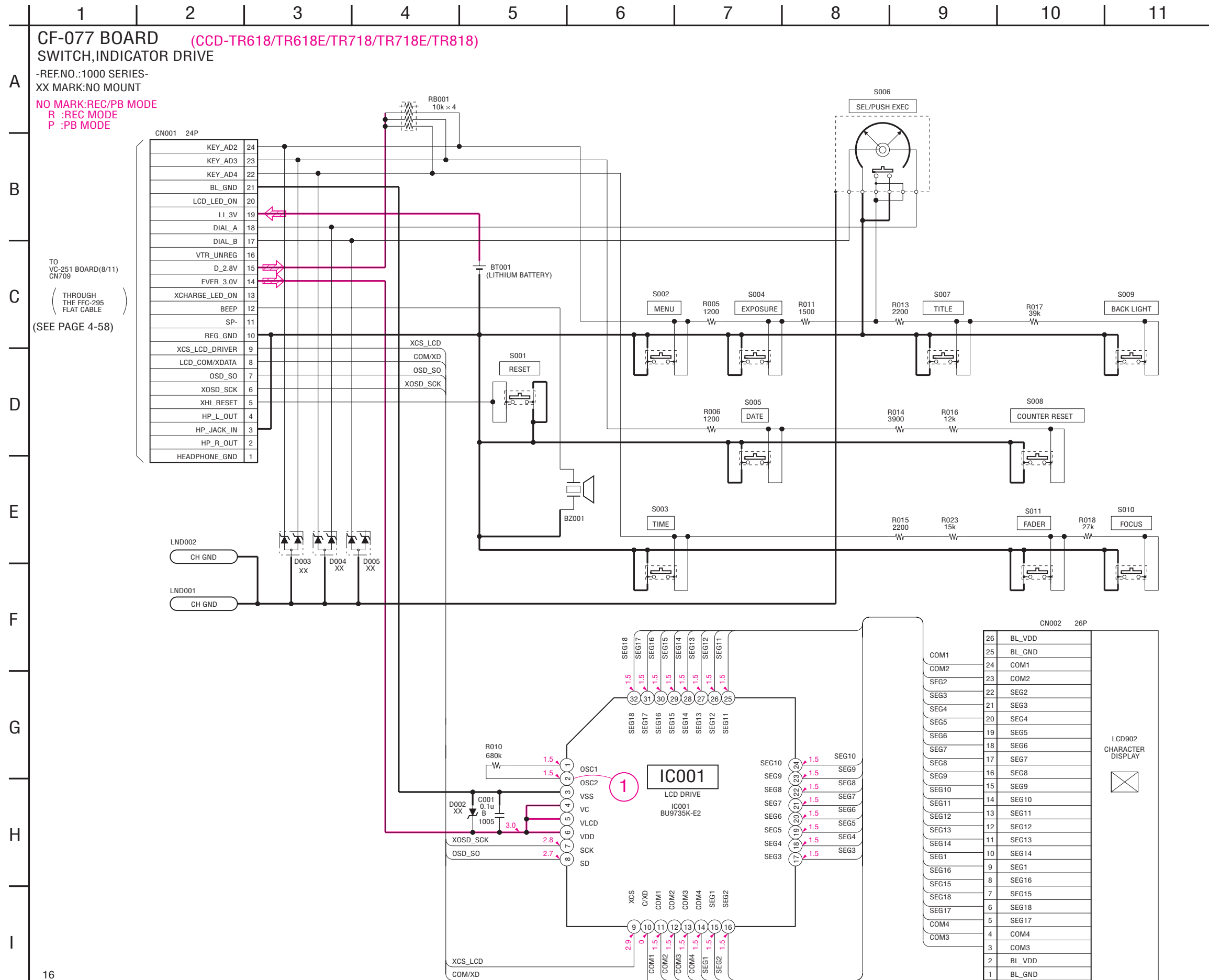

VC-251 (CAMERA PROCESSOR, Y/C PROCESSOR, FOCUS/ZOOM MOTOR DRIVE, REC/PB AMP, LINE I/O AMP, SERVO, MODE CONTROL, HI CONTROL, AUDIO, DC/DC CONVERTER, CONNECTOR) PRINTED WIRING BOARD

— Ref. No. VC-251 Board; 10,000 Series —

VC-251 BOARD (SIDE A)

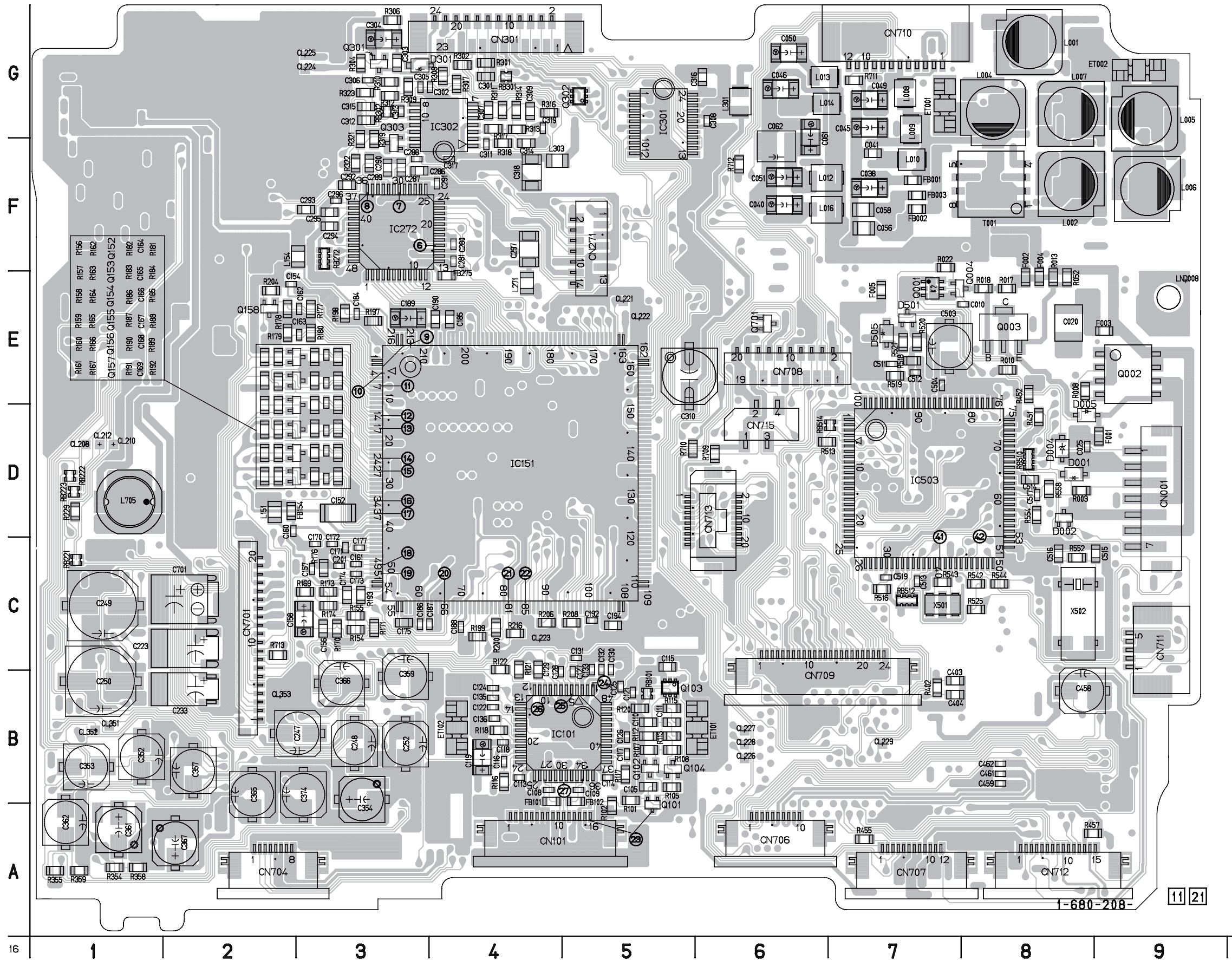

For printed wiring board

- Refer to pages 4-72,4-73 for parts location.
- VC-251 board consists of multiple layers. However, only the sides (layers) A and B are shown.
- Chip parts

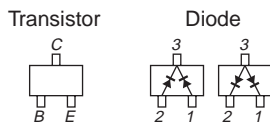

There are a few cases that the part printed on this diagram isn't mounted in this model.

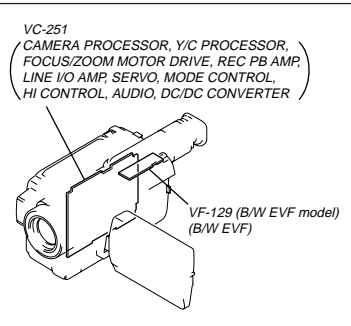

CCD-TR618/TR618E/TR718E/TR728E/TR818/TRV49/TRV49E/TRV58/
TRV58E/TRV59E/TRV68/TRV78/TRV78E/TRV88/TRV98/TRV98E

For Schematic Diagram

- Refer to page 4-39 for printed wiring board.
- Refer to page 4-68 for waveforms.

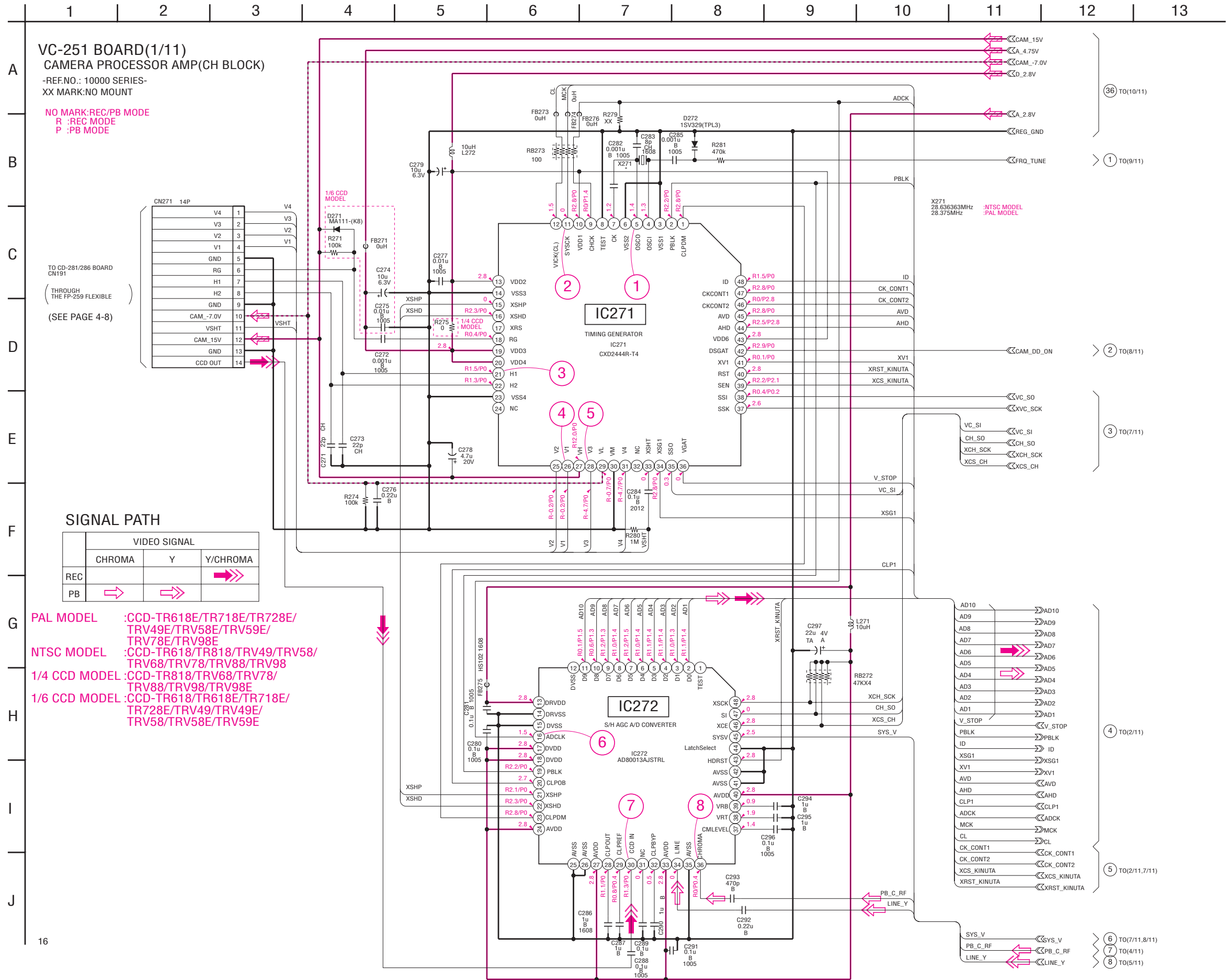

For Schematic Diagram
 • Refer to page 4-39 for printed wiring board.
 • Refer to page 4-68 for waveforms.

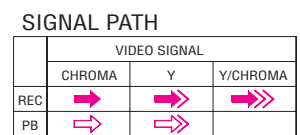
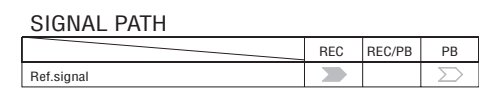
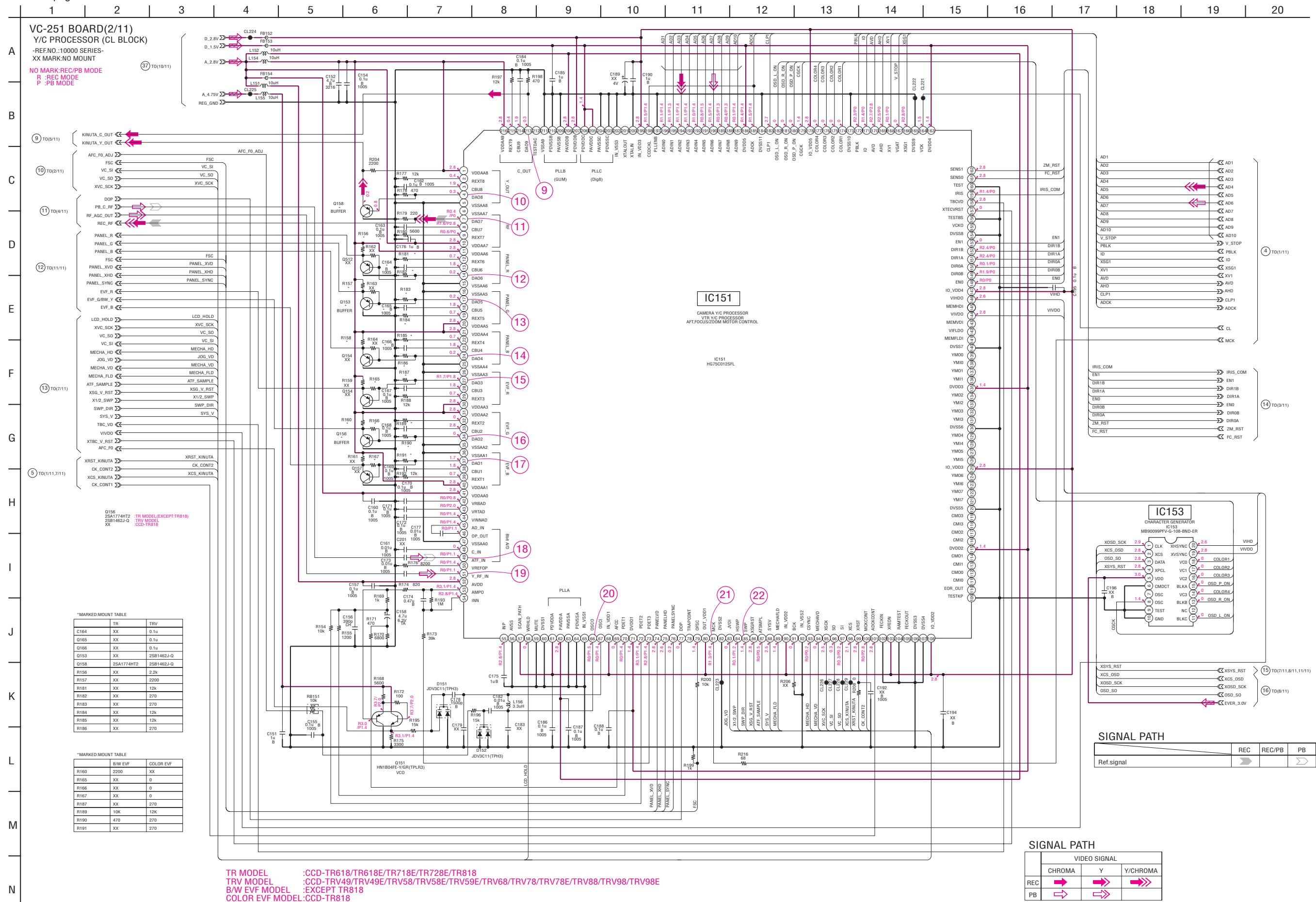

For Schematic Diagram
• Refer to page 4-39 for printed wiring board.

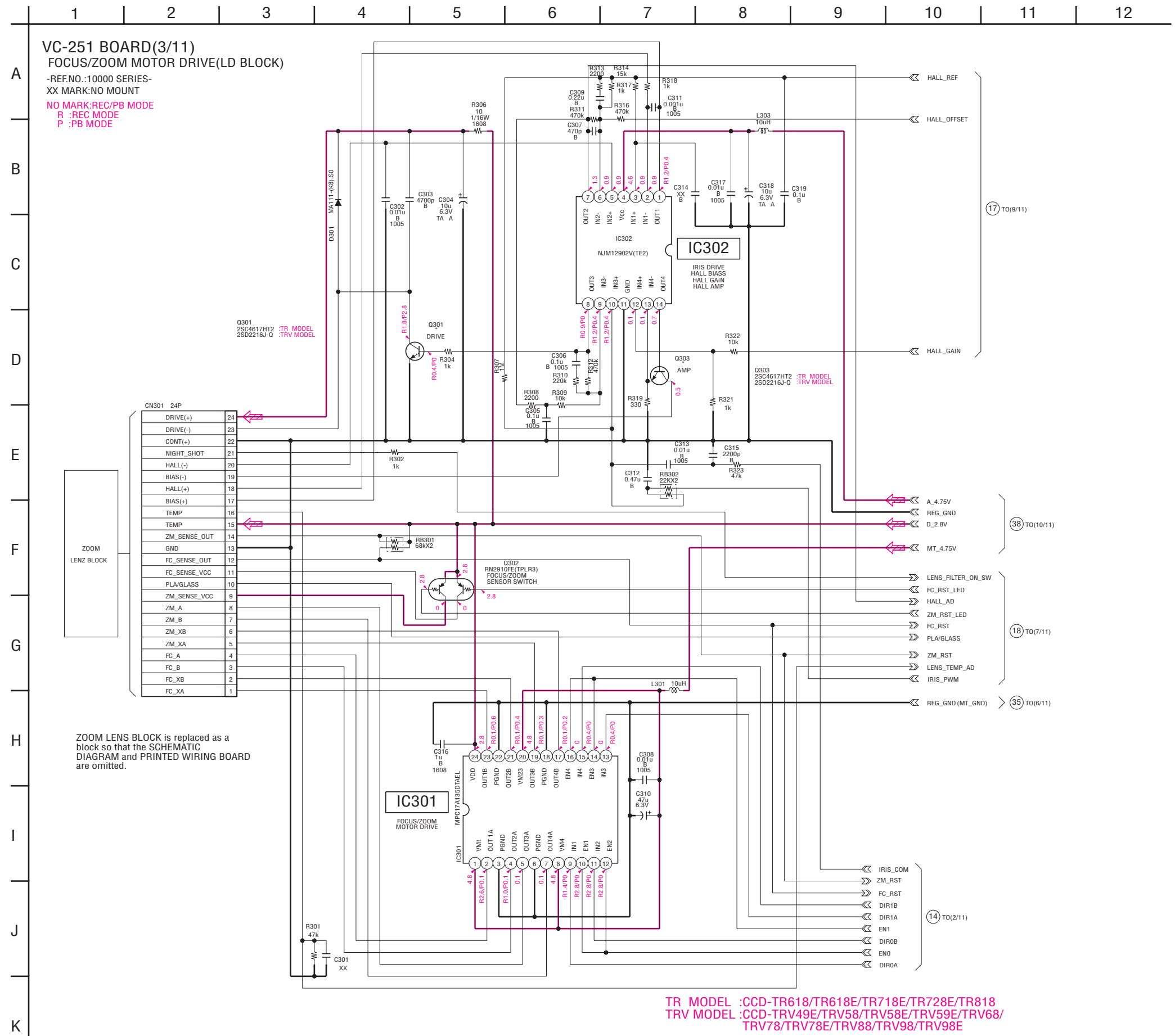

16

**CCD-TR618/TR618E/TR718E/TR728E/TR818/TRV49/TRV49E/TRV58/
TRV58E/TRV59E/TRV68/TRV78/TRV78E/TRV88/TRV98/TRV98E**

For Schematic Diagram
 • Refer to page 4-39 for printed wiring board.
 • Refer to pages 4-68,69 for waveforms.

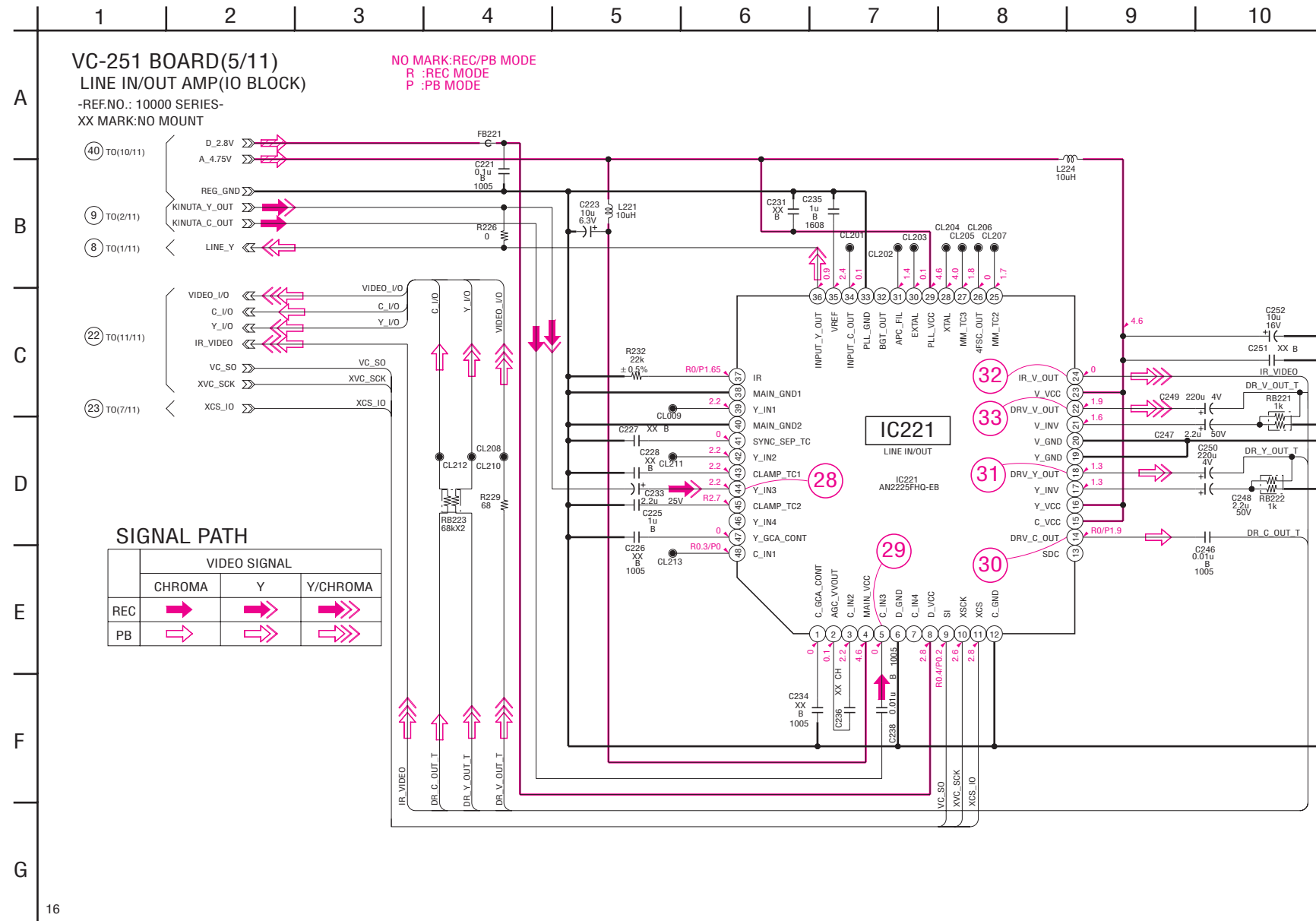

**FP-249 (S/T REEL SENSOR, TAPE TOP), FP-356 (TAPE END), FP-355 (TAPE LED)
FLEXIBLE BOARD**
 — Ref. No. FP-249, 356, 355 Flexible board; 5,000 series —

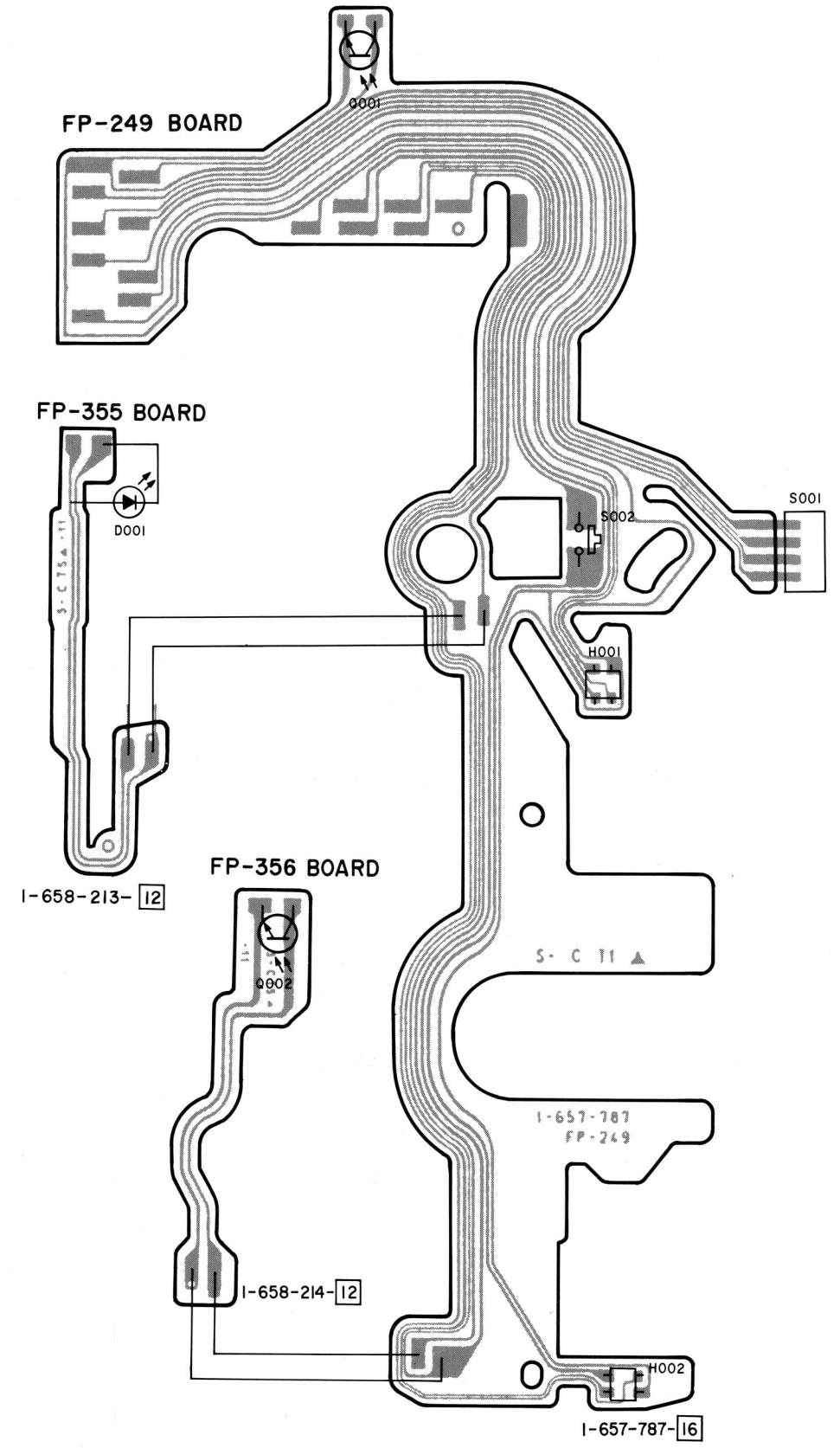

For Schematic Diagram

- Refer to page 4-39 for printed wiring board.
- Refer to page 4-69 for waveforms.

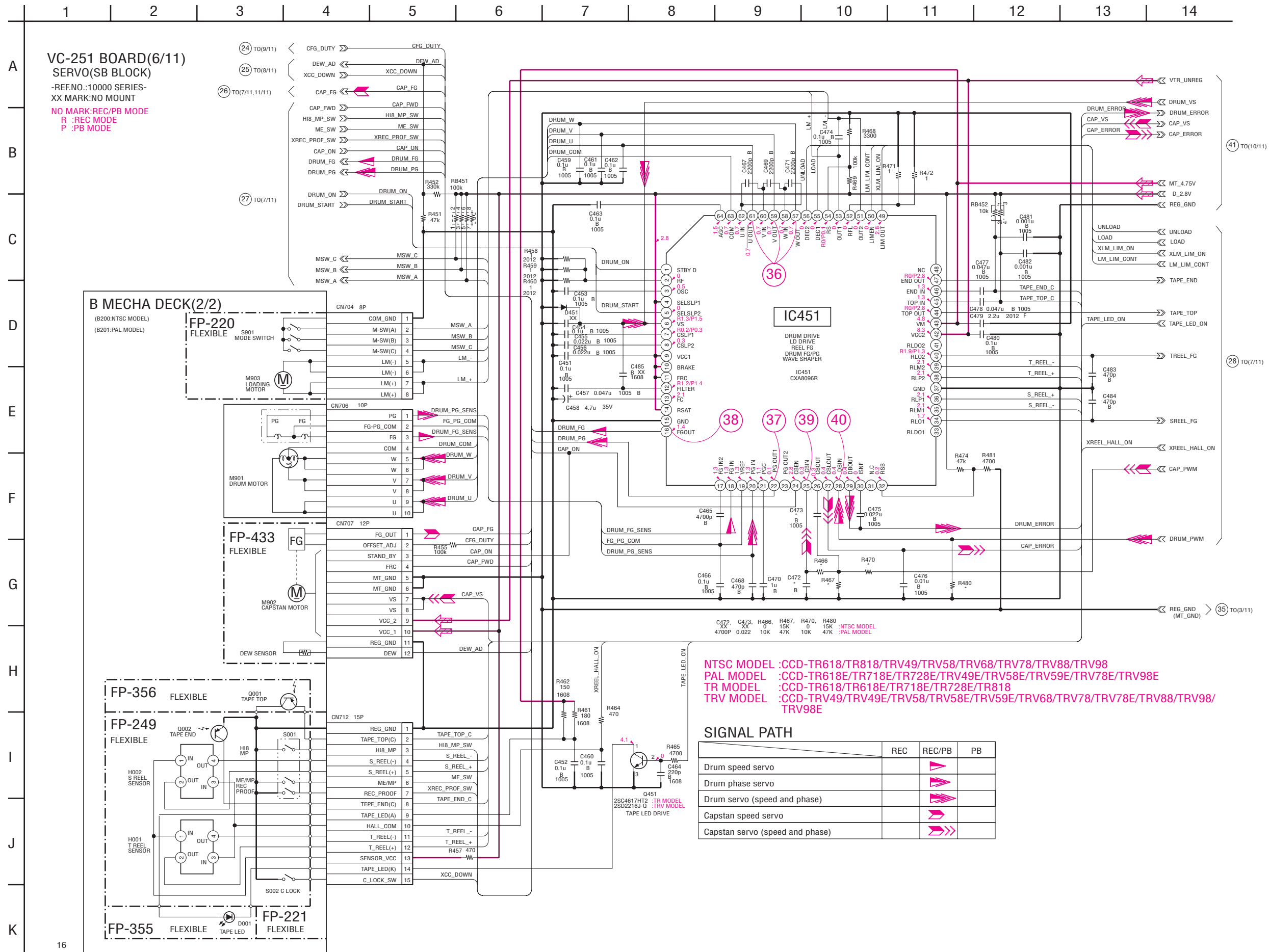

CCD-TR618/TR618E/TR718E/TR728E/TR818/TRV49/TRV49E/TRV58/
TRV58E/TRV59E/TRV68/TRV78/TRV78E/TRV88/TRV98/TRV98E

For Schematic Diagram
 • Refer to page 4-39 for printed wiring board.
 • Refer to page 4-69 for waveforms.

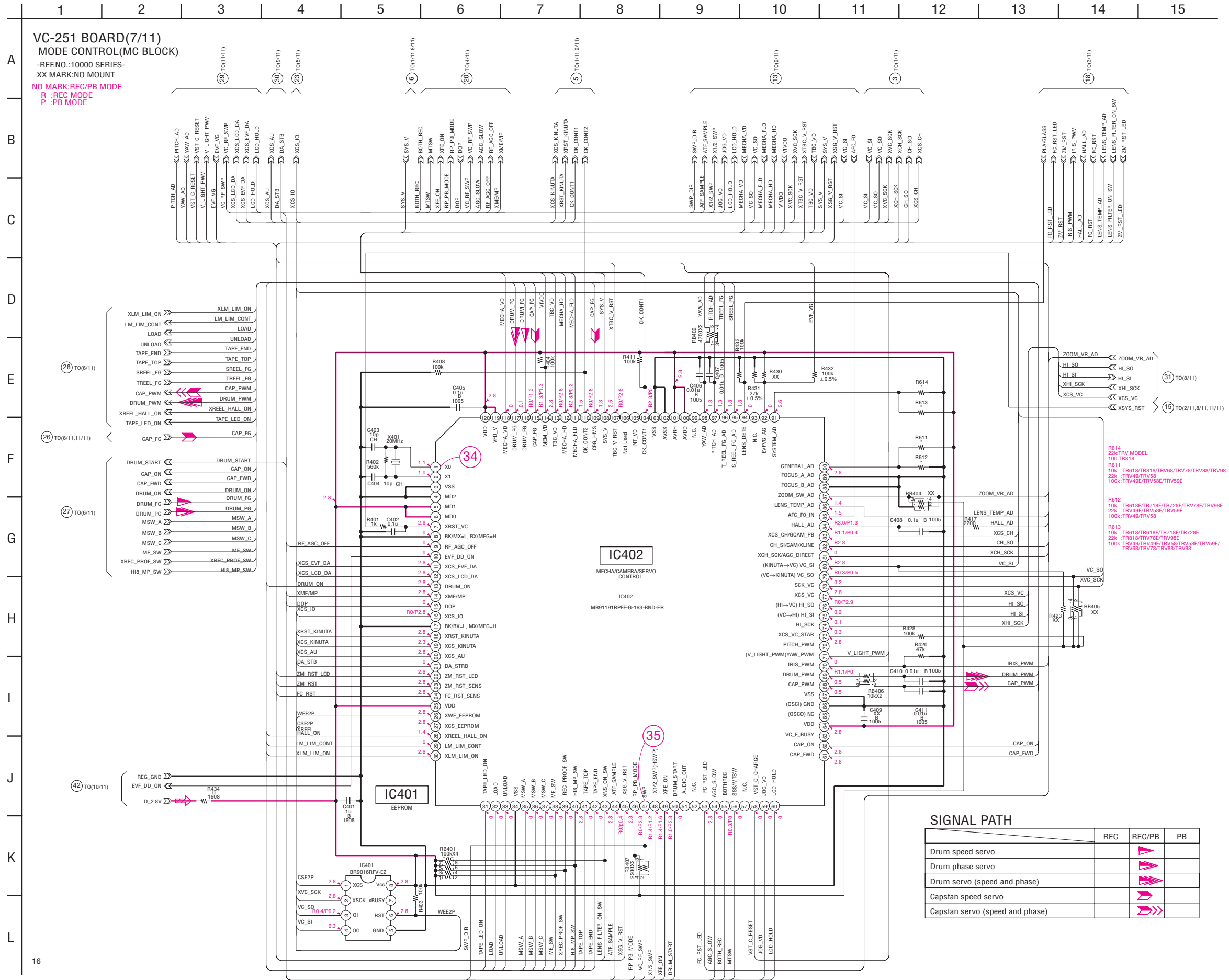

For Schematic Diagram

- Refer to page 4-39 for printed wiring board.
- Refer to page 4-69 for waveforms.

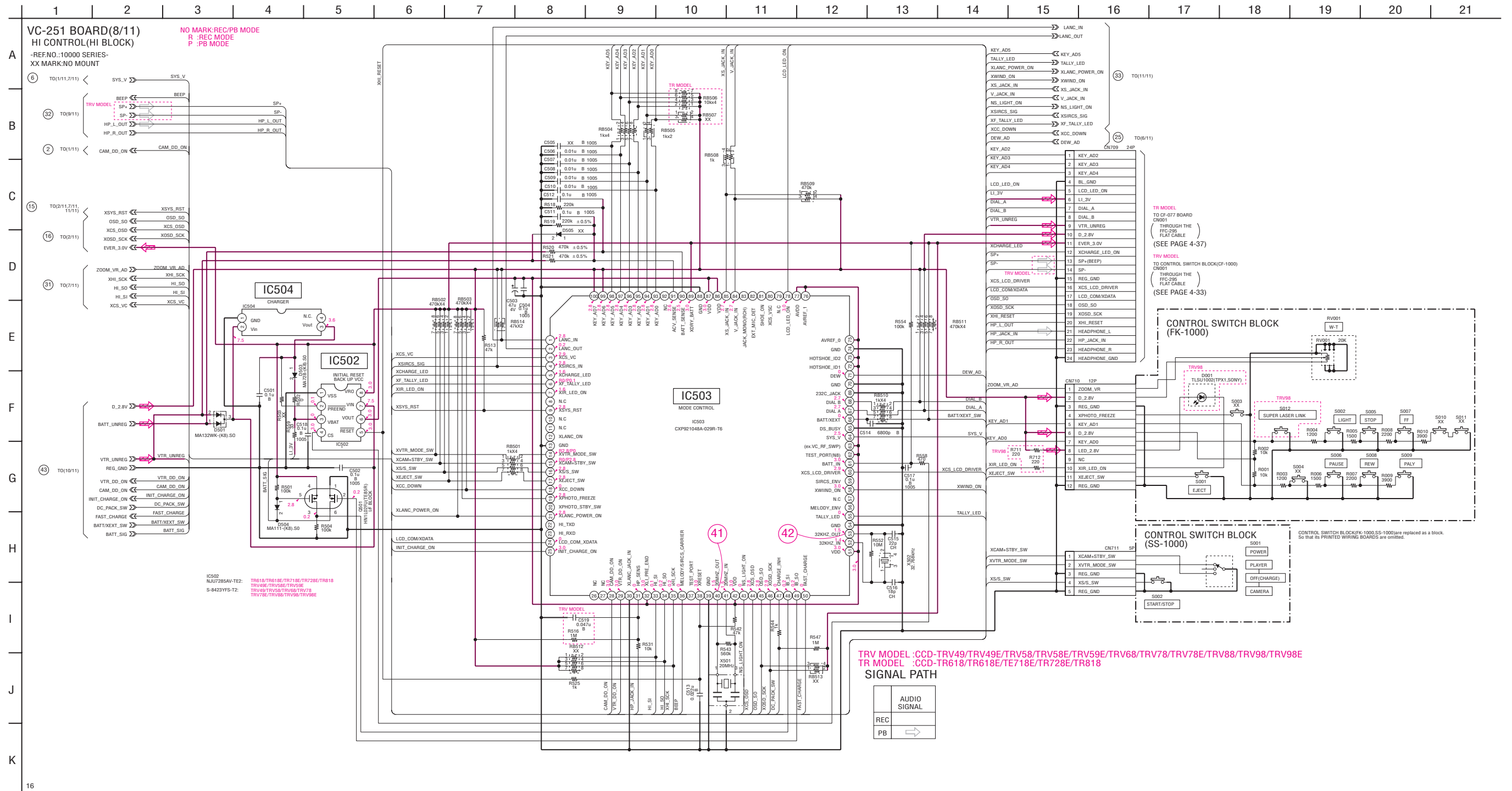

CCD-TR618/TR618E/TR718E/TR728E/TR818/TRV49/TRV49E/TRV58/
TRV58E/TRV59E/TRV68/TRV78/TRV78E/TRV88/TRV98/TRV98E

For Schematic Diagram
• Refer to page 4-39 for printed wiring board.

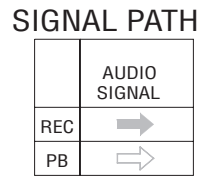
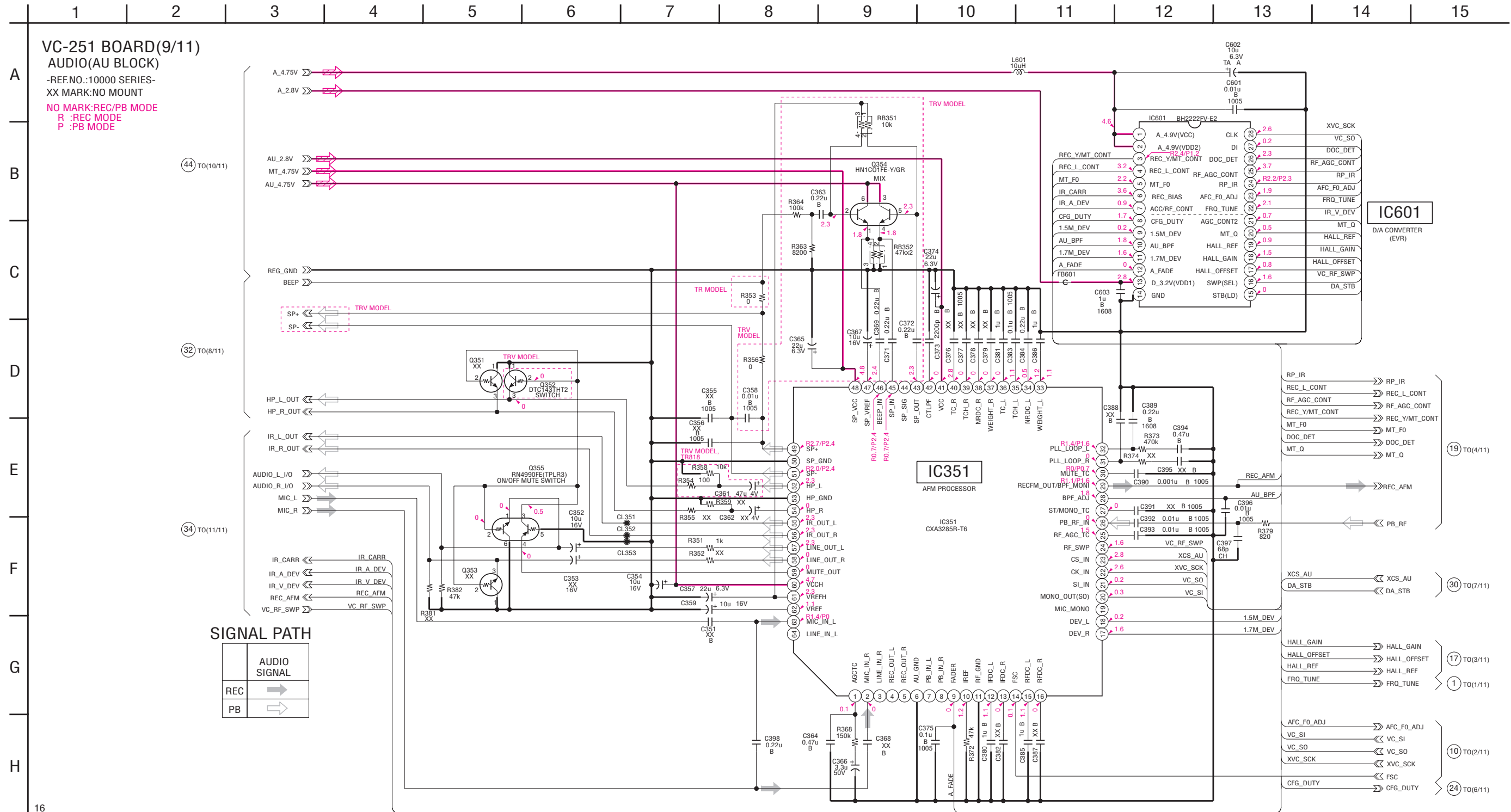

TR MODEL : CCD-TR618/TR618E/TR718E/TR728E/TR818
TRV MODEL : CCD-TRV49/TRV49E/TRV58/TRV58E/TRV59E/TRV68/TRV78/TRV78E/TRV88/TRV98/TRV98E

For Schematic Diagram

- Refer to page 4-39 for printed wiring board.
- Refer to page 4-69 for waveforms.

1 2 3 4 5 6 7 8 9 10 11 12 13 14 15 16 17

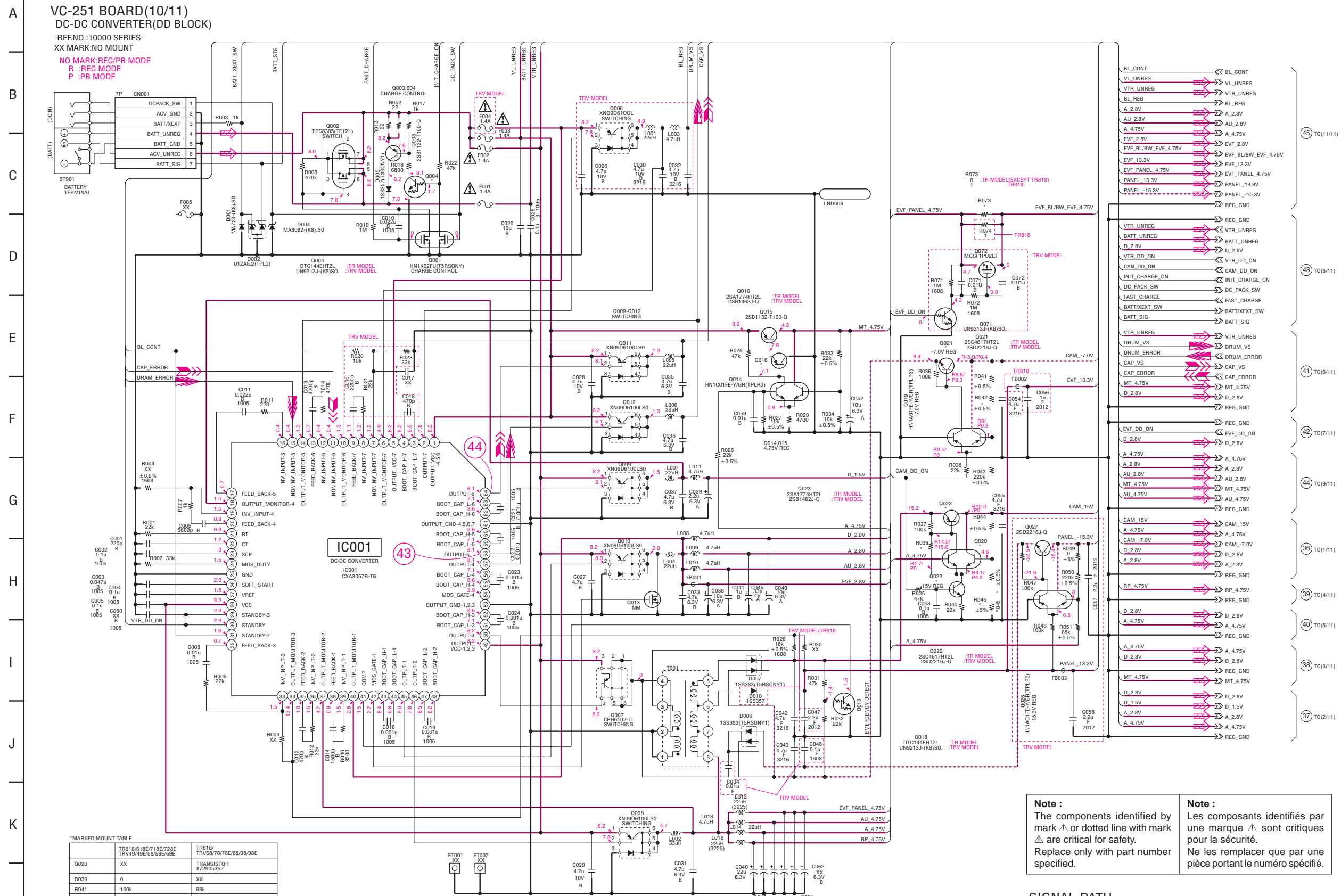

BL_CONT	←	BL_CONT	
VL_UNREG	→	VL_UNREG	
VTR_UNREG	→	VTR_UNREG	
BL_REG	→	BL_REG	
A_2.8V	→	A_2.8V	
AU_2.8V	→	AU_2.8V	
A_4.75V	→	A_4.75V	
EVF_2.8V	→	EVF_2.8V	
EVF_BL/BW_EVF_4.75V	→	EVF_BL/BW_EVF_4.75V	
EVF_13.3V	→	EVF_13.3V	
EVF_PANEL_4.75V	→	EVF_PANEL_4.75V	
PANEL_13.3V	→	PANEL_13.3V	
PANEL_-15.3V	→	PANEL_-15.3V	
REG_GND	→	REG_GND	
VTR_UNREG	→	VTR_UNREG	
BATT_UNREG	→	BATT_UNREG	
D_2.8V	→	D_2.8V	
VTR_DD_ON	→	VTR_DD_ON	
CAN_DD_ON	→	CAN_DD_ON	
INIT_CHARGE_ON	→	INIT_CHARGE_ON	
DC_PACK_SW	→	DC_PACK_SW	
FAST_CHARGE	→	FAST_CHARGE	
BATT/XEXT_SW	→	BATT/XEXT_SW	
BATT_SIG	→	BATT_SIG	
VTR_UNREG	→	VTR_UNREG	
DRUM_VS	→	DRUM_VS	
DRUM_ERROR	→	DRUM_ERROR	
CAP_VS	→	CAP_VS	
CAP_ERROR	→	CAP_ERROR	
MT_4.75V	→	MT_4.75V	
D_2.8V	→	D_2.8V	
REG_GND	→	REG_GND	
EVF_DD_ON	→	EVF_DD_ON	
D_2.8V	→	D_2.8V	
A_4.75V	→	A_4.75V	
A_2.8V	→	A_2.8V	
AU_2.8V	→	AU_2.8V	
MT_4.75V	→	MT_4.75V	
AU_4.75V	→	AU_4.75V	
REG_GND	→	REG_GND	
CAM_15V	→	CAM_15V	
A_4.75V	→	A_4.75V	
CAM_-7.0V	→	CAM_-7.0V	
D_2.8V	→	D_2.8V	
A_2.8V	→	A_2.8V	
REG_GND	→	REG_GND	
RP_4.75V	→	RP_4.75V	
REG_GND	→	REG_GND	
D_2.8V	→	D_2.8V	
A_4.75V	→	A_4.75V	
REG_GND	→	REG_GND	
A_4.75V	→	A_4.75V	
D_2.8V	→	D_2.8V	
REG_GND	→	REG_GND	
MT_4.75V	→	MT_4.75V	
D_2.8V	→	D_2.8V	
D_1.5V	→	D_1.5V	
A_2.8V	→	A_2.8V	
A_4.75V	→	A_4.75V	
REG_GND	→	REG_GND	

Note:
The components identified by mark Δ or dotted line with mark Δ are critical for safety. Replace only with part number specified.

Note:
Les composants identifiés par une marque Δ sont critiques pour la sécurité. Ne les remplacer que par une pièce portant le numéro spécifié.

SIGNAL PATH

	REC	REC/PB	PB
Drum servo (speed and phase)		→	
Capstan servo (speed and phase)		→	

*MARKED-MOUNT TABLE

	TR618/618E/718E/728E TRV49/49E/58/58E/59E	TR818/ TRV68/78/78E/88/88E/98E
Q020	XX	TRANSISTOR 872905352
R039	0	XX
R041	100k	68k
R042	10k	22k
R044	XX	100k
R045	XX	47k
R046	XX	18k

TR MODEL : CCD-TR618/TR618E/TR718E/TR728E/TR818
TRV MODEL : CCD-TRV49/TRV49E/TRV58/TRV58E/TRV59E/TRV68/TRV78/TRV78E/TRV88/TRV98/TRV98E

CCD-TR618/TR618E/TR718E/TR728E/TR818/TRV49/TRV49E/TRV58/ TRV58E/TRV59E/TRV68/TRV78/TRV78E/TRV88/TRV98/TRV98E

For Schematic Diagram

Refer to page 4-39 for printed wiring board.



VC-251 BOARD(11/11) CONNECTOR(CN BLOCK)

-REF.NO.:10000 SERIES-
XX MARK:NO MOUNT

NO MARK:REC/PB MODE
R :REC MODE
P :PB MODE

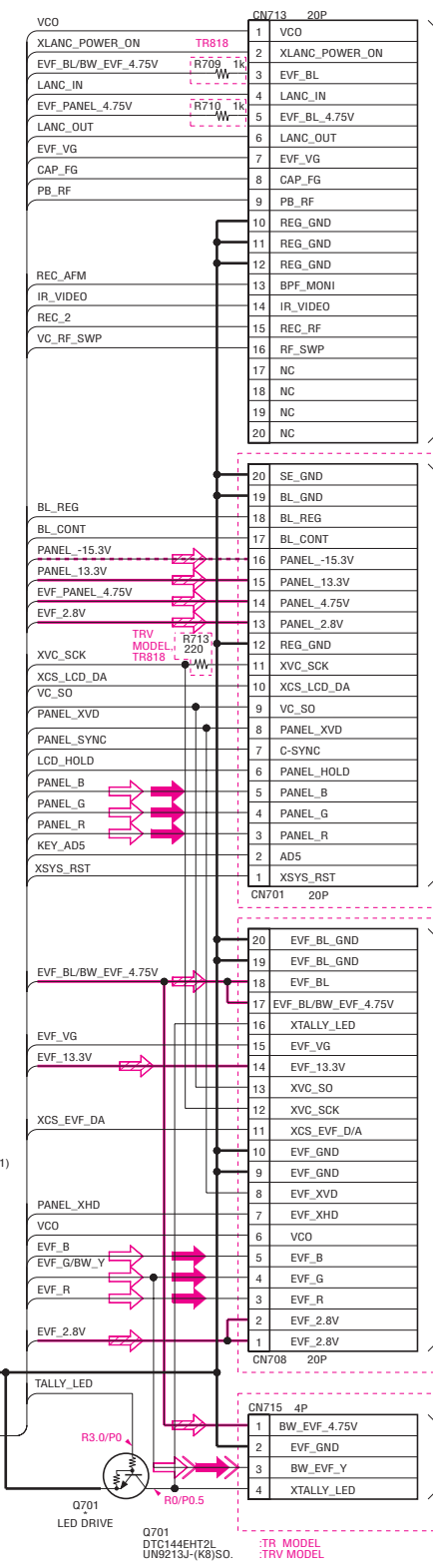
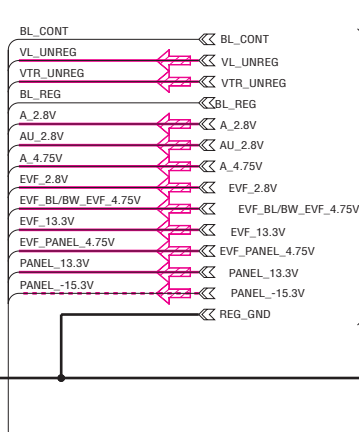
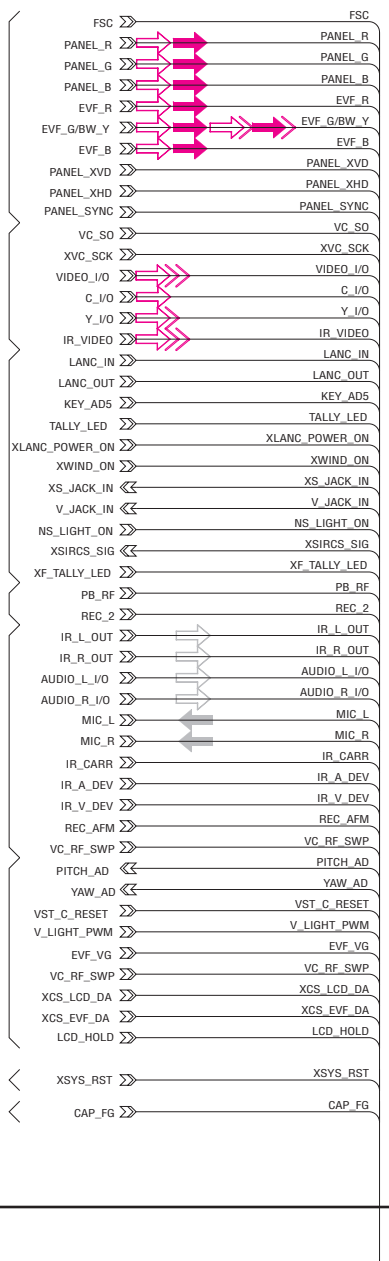
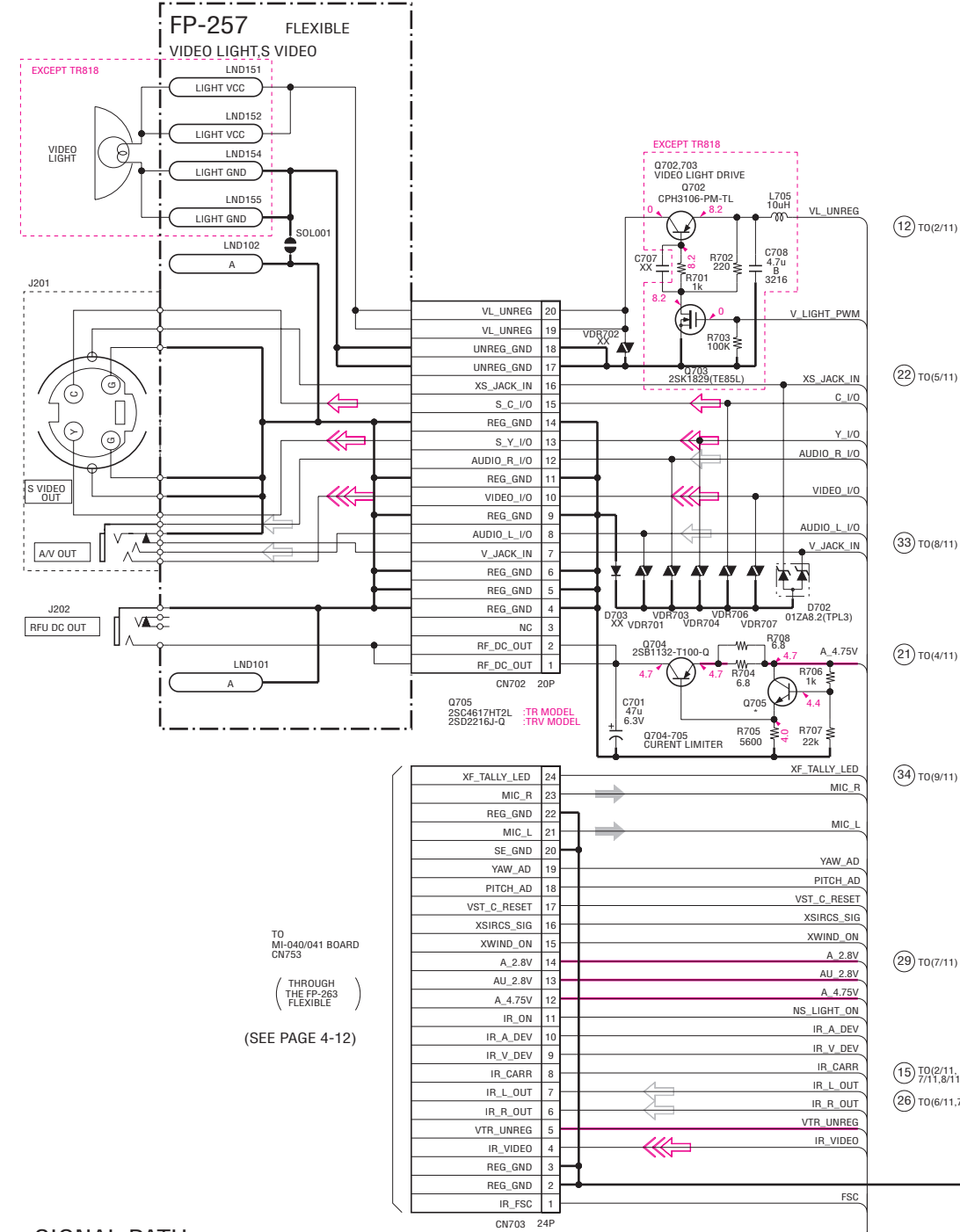

CPC
(FOR CHECK)

TRV MODEL
TO PD-131 BOARD
CN5701
(SEE PAGE 4-19)

TR818
TO VF-141 BOARD
CN4501
(THROUGH THE FP-151 FLEXIBLE)
(SEE PAGE 4-29)

EXCEPT TR818
TO VF-129 BOARD
CN901
(THROUGH THE FP-256 FLEXIBLE)
(SEE PAGE 4-25)

TR MODEL :CCD-TR618/TR618E/TR718E/TR728E/TR818
TRV MODEL :CCD-TRV49/TRV49E/TRV58/TRV58E/TRV59E/TRV68/
TRV78/TRV78E/TRV88/TRV98/TRV98E

SIGNAL PATH

	VIDEO SIGNAL			AUDIO SIGNAL
	CHROMA	Y	Y/CHROMA	
REC	→	→	→	→
PB	→	→	→	→

TO MI-040/041 BOARD
CN753
(THROUGH THE FP-263 FLEXIBLE)
(SEE PAGE 4-12)

FP-257 (VIDEO LIGHT, S VIDEO) FLEXIBLE BOARD

— Ref. No. FP-257 Flexible board; 10,000 Series —

FP-257 FLEXIBLE

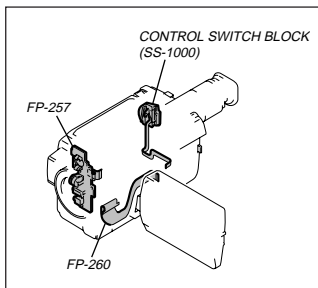
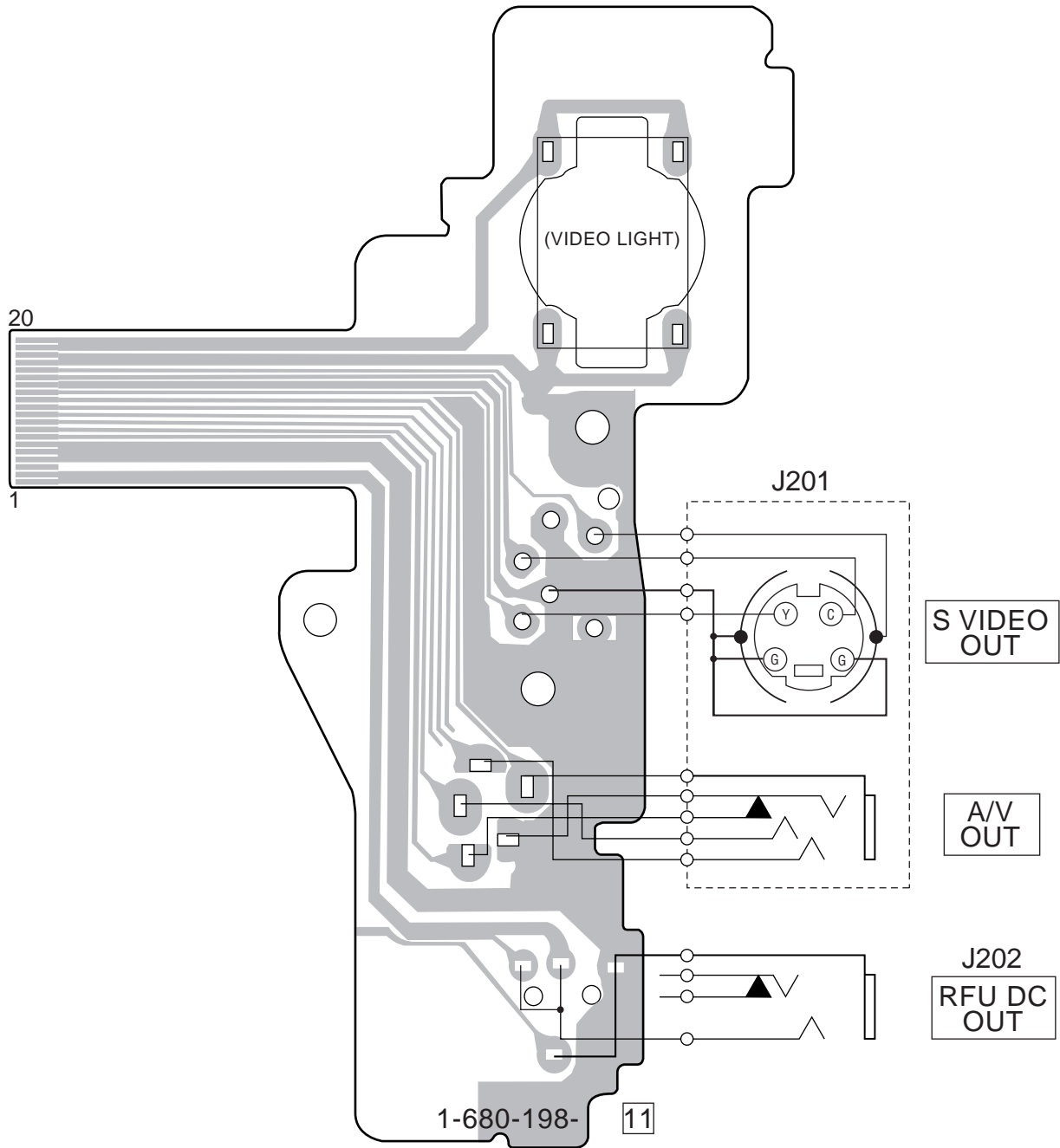

4-3. WAVEFORMS

CD-281/286 BOARD
REC

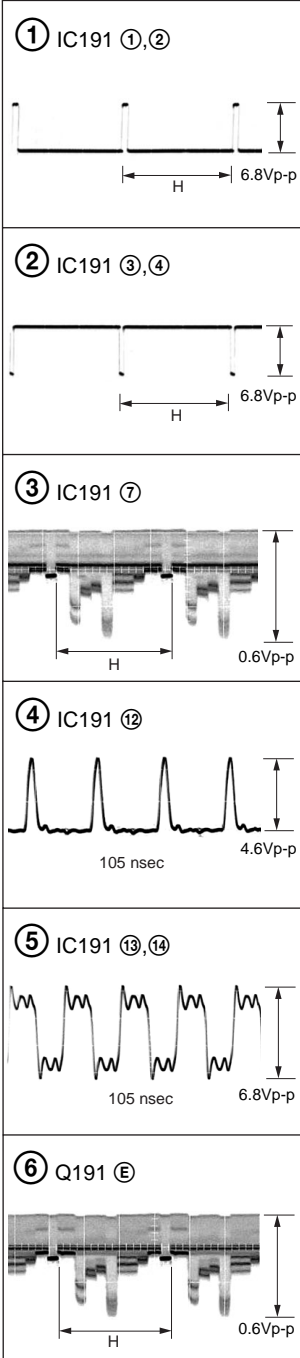

MI-040/041 BOARD
REC/PB

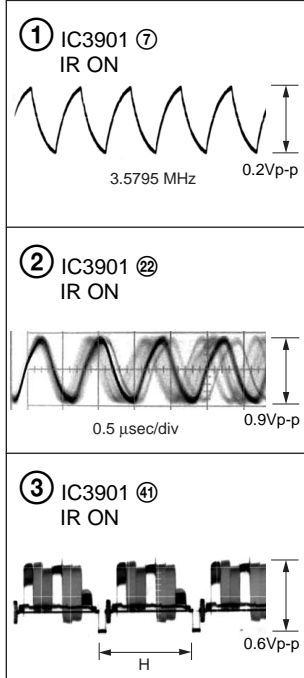

PD-131 BOARD

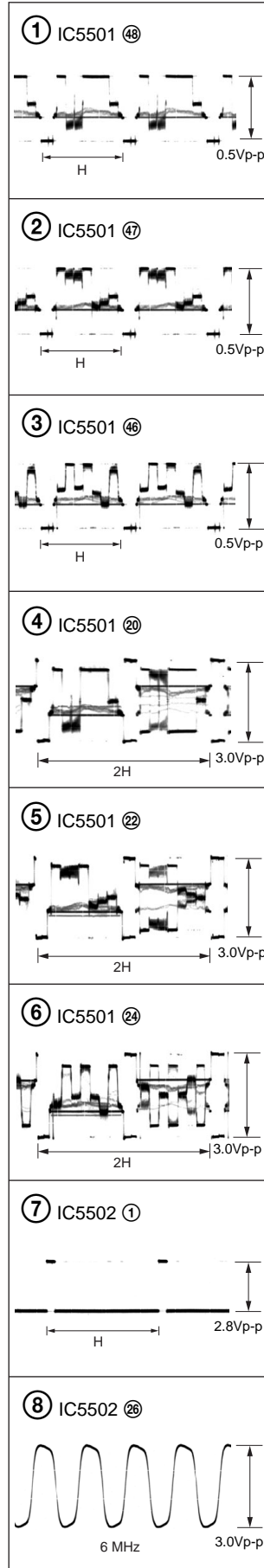

VF-129 BOARD
REC/PB

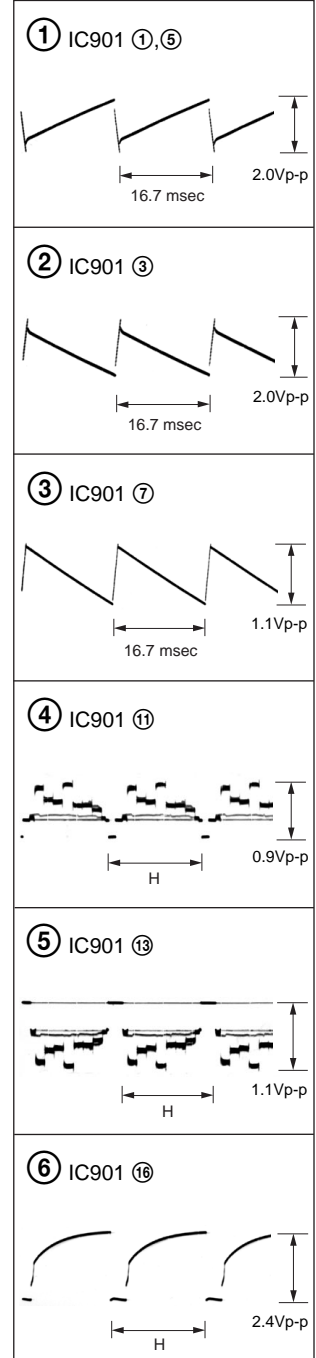

VF-141 BOARD

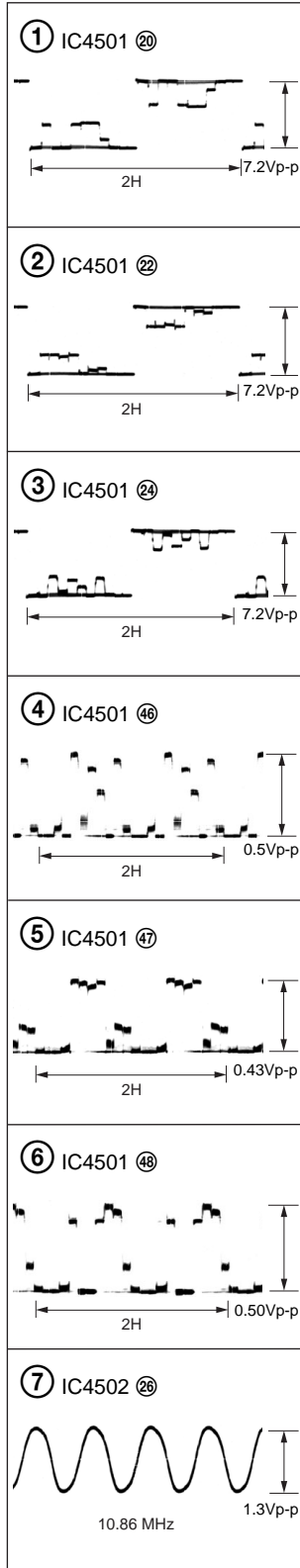

LB-062 BOARD

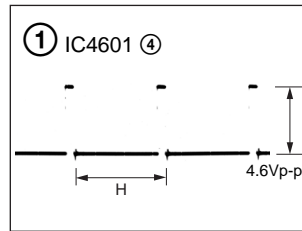

CF-077 BOARD

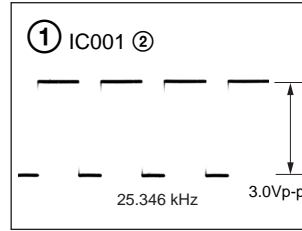

**CCD-TR618/TR618E/TR718E/TR728E/TR818/TRV49/TRV49E/TRV58/
TRV58E/TRV59E/TRV68/TRV78/TRV78E/TRV88/TRV98/TRV98E**

VC-251 BOARD

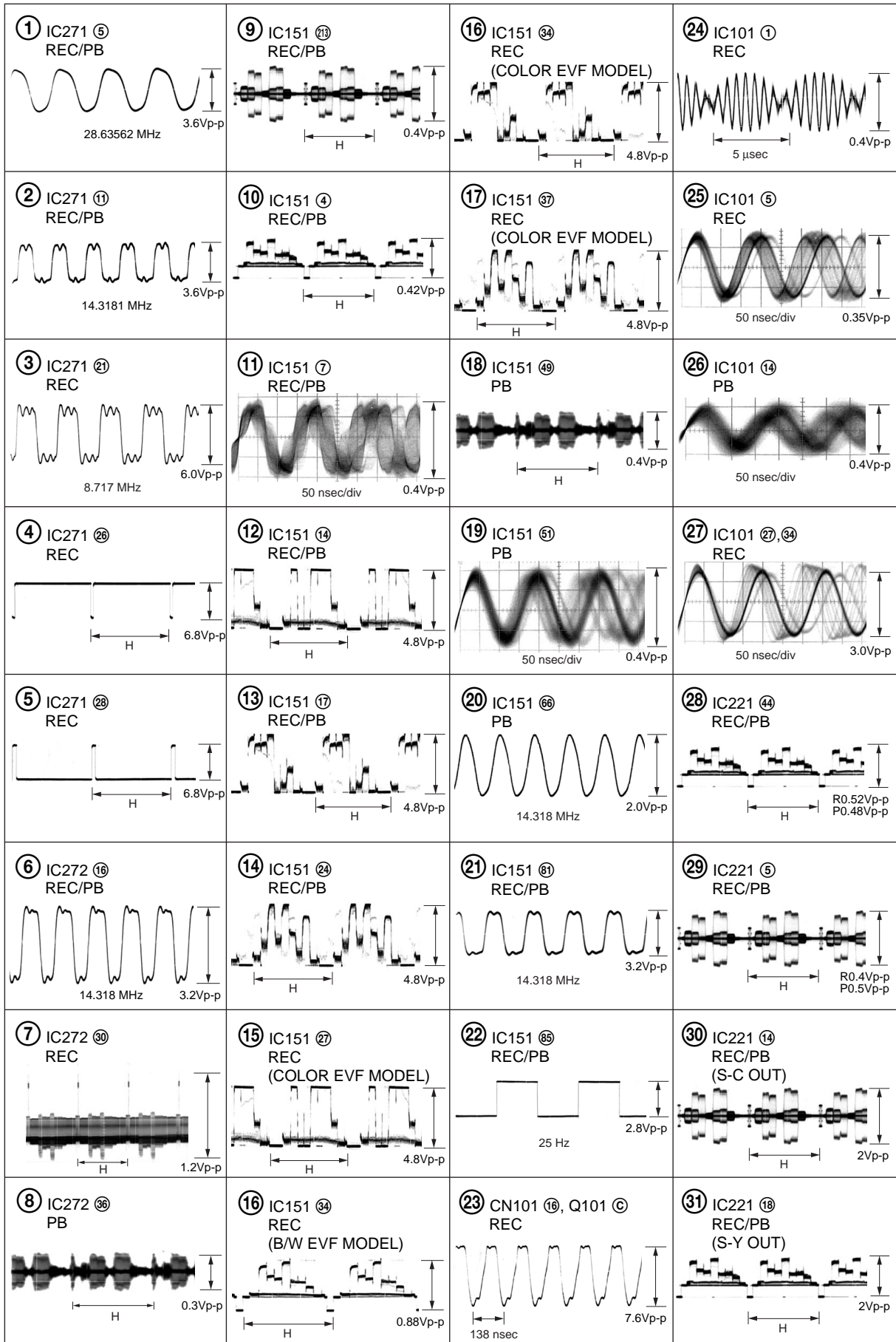

VC-251 BOARD

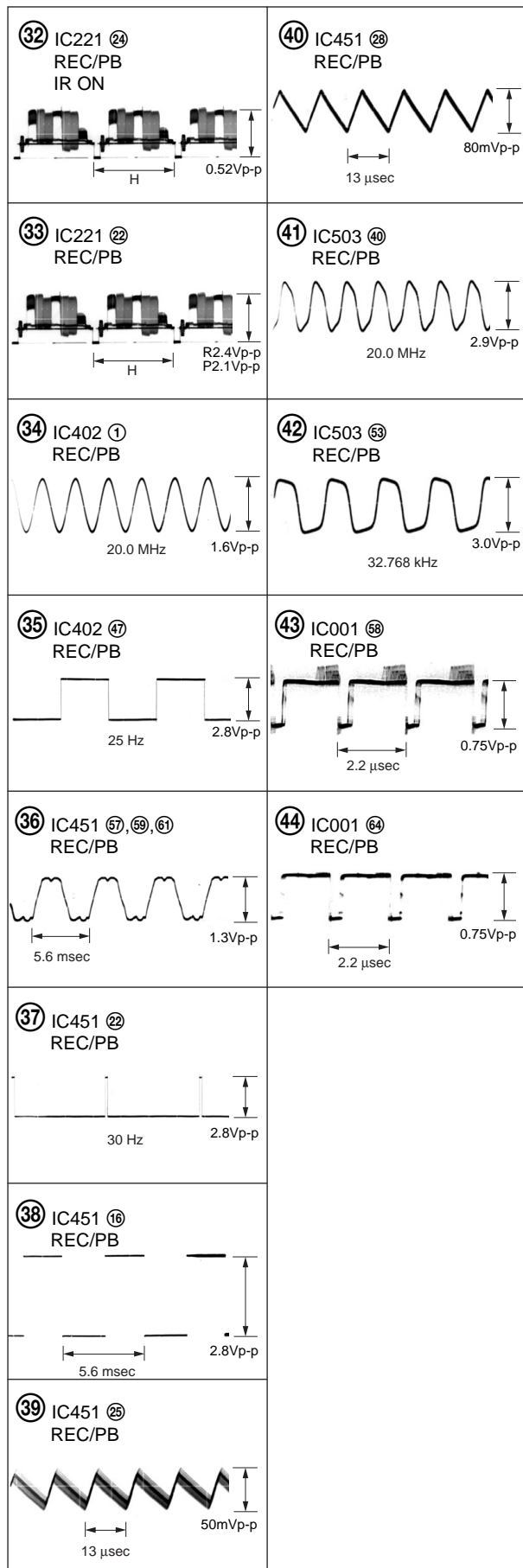

**CCD-TR618/TR618E/TR718E/TR728E/TR818/TRV49/TRV49E/TRV58/
TRV58E/TRV59E/TRV68/TRV78/TRV78E/TRV88/TRV98/TRV98E**

4-4. MOUNTED PARTS LOCATION

**CD-281/286 BOARD
(SIDE A)**

C191 B-2
C196 B-1

IC191 A-2

**CD-281/286 BOARD
(SIDE B)**

C194 B-5
C195 A-4
C197 A-4

CN191 A-5

L191 B-4

Q191 A-5

R191 A-5
R192 A-4
R193 A-4
R194 B-4
R195 B-5
R198 A-4

MI-040/041 BOARD (SIDE A)

C758 D-2
C762 D-1
C775 B-2
C784 C-2
C791 B-2
C794 C-3
C799 B-4
C800 C-4
C808 C-4
C809 C-4
C810 B-3
C3901 B-2
C3902 B-2
C3903 B-2
C3904 B-2
C3905 B-1
C3906 B-1
C3907 B-2
C3908 B-1
C3910 B-2
C3911 B-2
C3912 C-3
C3913 B-3
C3914 A-2
C3915 A-1
C3916 A-1
C3917 A-2
C3918 A-2
C3919 A-1
C3920 A-1
C3921 A-3
C3922 A-1
C3923 A-3
C3924 A-1
C3925 A-1
C3926 A-2
C3929 A-2
C3930 A-2
C3932 C-3
C3934 A-3
C3935 A-2

D752 B-3
D753 B-4
D754 A-1
D755 C-4
D756 C-4
D3901 B-4
D3902 A-3
D3903 A-4

IC751 B-3
IC3901 A-2

L3903 A-3

R786 B-4
R797 C-3
R3901 A-3
R3903 B-2
R3904 B-2
R3905 B-1
R3907 B-1
R3908 A-3
R3909 A-2
R3912 A-3
R3913 A-1
R3914 A-1
R3915 A-2
R3916 A-2
R3917 A-2
R3926 A-3
R3927 B-3
R3931 B-2
R3945 A-1
R3946 A-3

SE751 C-2
SE752 E-2

MI-040/041 BOARD (SIDE B)

C759 E-7
C761 B-5
C763 C-7
C764 C-5
C768 C-7
C769 B-5
C770 C-5
C772 C-7
C773 B-5
C774 C-7
C776 C-5
C777 C-7
C779 B-5
C780 B-5
C781 C-5
C782 C-5
C783 B-5
C785 B-5
C786 B-5
C787 C-6
C788 B-5
C789 B-8
C796 C-5
C3909 B-7
C3931 A-7
C3933 B-6

CN751 C-5
CN752 C-6
CN753 B-6

IC752 B-5
IC753 B-7

L751 B-6
L3902 B-7
L3904 A-6
L3905 A-6
L3906 B-6

Q3901 A-7
Q3902 A-7
Q3903 A-5
Q3904 A-5

R757 C-5
R761 B-5
R764 B-5
R765 B-5
R766 C-5
R767 C-5
R768 B-5
R769 C-5
R770 B-5
R771 B-5
R772 B-5
R774 C-5
R775 C-6
R776 C-6
R779 B-7
R780 C-7
R782 B-7
R783 B-7
R784 B-7
R785 B-7
R788 B-5
R789 B-5
R3902 B-7
R3919 A-7
R3920 A-7
R3921 A-7
R3922 A-5
R3923 A-6
R3924 B-6
R3925 A-6
R3928 B-6
R3929 A-6
R3930 B-7

RB751 C-7
RB752 E-7
RB3901 B-8

PD-131 BOARD (SIDE A)

C5501 C-3
C5502 C-3
C5503 B-4
C5504 B-3
C5505 B-4
C5506 B-4
C5507 B-4
C5508 C-3
C5509 C-4
C5510 B-4
C5511 B-3
C5512 B-3
C5513 B-4
C5514 C-4
C5515 B-3
C5516 A-3
C5517 A-4
C5518 A-4
C5519 A-4
C5520 C-3
C5521 B-2
C5522 B-1
C5523 A-3
C5524 A-1
C5525 B-4
C5526 B-4
C5527 B-4
C5528 C-2
C5529 B-3
C5530 A-2
C5531 A-2
C5532 B-1
C5601 A-4
C5602 C-5
C5603 C-6
C5604 A-5
C5605 A-5
C5606 A-6
C5607 C-5
C5608 C-6

CN5501 A-2
CN5502 B-2
CN5601 A-6
CN5701 B-6
CN5702 D-6

D5501 C-3
D5502 A-4
D5503 A-2
D5601 A-5
D5603 D-2
D5604 D-2

ET5601 A-5
ET5602 C-6

FB5501 C-3
FB5502 C-4

IC5501 B-4
IC5502 B-3
IC5601 A-4
IC5602 A-5

L5501 C-3
L5502 C-4
L5503 B-3
L5601 C-5

Q5501 C-3
Q5502 B-1
Q5503 A-2
Q5504 A-2
Q5505 B-1
Q5601 A-4
Q5602 C-6
Q5603 A-5

R5501 C-4
R5502 C-4
R5503 C-4
R5504 B-3
R5505 B-4
R5506 B-4
R5507 B-4
R5508 B-4
R5509 B-4
R5510 B-3
R5511 B-3
R5512 B-4
R5513 B-3
R5514 A-3
R5515 A-3
R5516 C-2
R5517 B-2
R5518 B-2
R5519 B-2
R5520 A-3
R5521 B-2
R5522 B-2
R5523 C-4
R5524 C-4
R5525 C-2
R5526 C-3
R5527 A-1
R5528 A-2
R5529 A-2
R5530 A-2
R5531 C-4
R5532 B-1
R5533 B-2
R5534 B-3
R5535 B-3
R5539 D-6
R5601 C-5
R5602 A-5
R5603 B-5
R5604 C-5
R5605 A-6
R5606 A-5
R5607 A-5
R5608 D-2
R5609 D-2
R5610 A-5
R5611 A-5
R5702 D-6
R5703 C-6

RB5501 A-3
RB5502 A-2
RB5503 A-2
RB5601 A-4

T5601 B-6

PD-131 BOARD (SIDE B)

D5602 A-8

**CCD-TR618/TR618E/TR718E/TR728E/TR818/TRV49/TRV49E/TRV58/
TRV58E/TRV59E/TRV68/TRV78/TRV78E/TRV88/TRV98/TRV98E**

VF-129 BOARD (SIDE A)

C903	A-2	R914	C-1
C904	B-2	R915	A-1
C906	A-2	R916	A-1
C907	A-1	R917	A-1
C909	B-1	R922	D-1
C913	A-2	R927	B-1
		R928	B-1
CN902	B-1	R929	A-1
		R930	C-1
D901	A-1	R931	C-1
		R932	C-1
IC901	A-1		
		RV903	C-2
L901	B-1	RV904	D-1
L903	D-1		
		T901	D-1
R903	A-1	T902	D-1
R907	B-1		
R908	B-2	TH901	C-2
R909	B-2		
R910	B-2	W901	D-2
R912	A-2		
R913	C-2		

VF-129 BOARD (SIDE B)

C901	A-3	R901	A-3
C902	A-2	R902	A-2
C905	A-3	R904	A-3
C908	B-2	R905	A-2
C910	C-3	R906	A-2
C911	C-3	R911	A-3
C912	B-3	R918	C-2
C914	D-3	R919	C-2
C915	D-3	R920	C-2
C916	C-3	R921	D-2
		R923	D-3
CN901	B-3	R924	C-3
		R925	C-3
D903	D-3	R926	D-2
L902	B-2		
Q901	A-2		
Q902	B-2		
Q903	C-3		
Q904	C-2		

VF-141 BOARD (SIDE A)

C4501	B-1	Q4502	A-1
C4504	B-1	Q4503	A-1
C4510	B-2	Q4504	B-2
C4515	B-2		
C4516	B-2	R4505	A-1
C4517	A-2	R4506	A-1
C4521	A-2	R4507	A-1
C4524	A-2	R4508	B-2
C4527	B-2	R4522	B-2
		R4524	A-2
CN4502	A-2	R4525	A-2
		R4529	A-2
D4501	B-2	R4530	A-1
D4502	B-2	R4534	A-1
D4503	A-2	R4535	A-1
D4504	A-2	R4542	A-1
		R4543	A-2
FB4505	B-1	R4544	B-1
IC4502	A-2		
L4501	B-1		
L4504	B-2		

VF-141 BOARD (SIDE B)

C4503	A-5	R4515	B-4
C4505	A-5	R4516	B-4
C4506	A-5	R4517	B-4
C4507	A-5	R4518	A-4
C4508	B-5	R4520	B-4
C4509	B-5	R4521	B-4
C4511	B-4	R4523	B-4
C4512	B-4	R4526	A-4
C4513	A-4	R4527	A-4
C4514	A-4	R4528	A-4
C4518	A-4	R4545	B-4
C4519	A-4	R4546	B-4
C4520	A-4	R4547	A-4
C4523	B-4		
C4526	A-5		
CN4501	A-5		
FB4502	A-4		
IC4501	A-4		

LB-062 BOARD (SIDE A)

D4601	B-2
D4602	A-1
ND4601	A-1
R4603	A-2

LB-062 BOARD (SIDE B)

C4601	A-3
C4602	A-3
C4603	A-3
C4604	A-4
CN4601	A-4
IC4601	A-4
L4601	B-3
L4602	B-3
Q4601	A-3
R4601	A-4
R4602	B-3
R4604	A-3

T4601	B-4
-------	-----

CF-077 BOARD (SIDE A)

C001	F-6	S001	E-1
		S002	E-7
D002	F-6	S003	G-6
D003	F-3	S004	E-5
D004	F-3	S005	G-5
D005	F-4	S006	E-8
		S007	E-6
IC001	F-6	S008	G-6
		S009	F-2
		S010	E-3
		S011	F-1
R005	E-6		
R006	G-4		
R010	F-6		
R011	E-5		
R013	E-6		
R014	G-5		
R015	G-5		
R016	G-6		
R017	E-3		
R018	E-4		
R023	G-4		

CF-077 BOARD (SIDE B)

BT001	B-6
BZ001	B-2
CN001	B-4
CN002	A-6
RB001	B-3

**CCD-TR618/TR618E/TR718E/TR728E/TR818/TRV49/TRV49E/TRV58/
TRV58E/TRV59E/TRV68/TRV78/TRV78E/TRV88/TRV98/TRV98E**

VC-251 BOARD (SIDE A)

C010	E-8	C290	F-3	F002	E-8	R157	E-2	R711	G-7
C020	E-8	C291	F-4	F003	E-9	R158	D-2	R712	F-6
C025	D-8	C292	F-3	F004	E-8	R159	D-2	R713	C-2
C038	F-7	C293	F-3	F005	E-7	R160	D-2		
C040	F-6	C294	F-3			R161	D-2	RB101	B-5
C041	F-7	C295	F-3	FB001	F-7	R162	E-2	RB221	C-1
C045	F-7	C296	F-3	FB002	F-7	R163	E-2	RB222	D-1
C046	G-6	C297	F-4	FB003	F-7	R164	D-2	RB223	D-1
C049	G-7	C301	G-4	FB101	A-4	R165	D-2	RB272	F-3
C050	G-6	C302	G-4	FB102	A-5	R166	D-2	RB302	G-3
C051	F-6	C303	G-3	FB154	D-2	R167	D-2	RB510	D-8
C056	F-7	C304	G-3	FB275	E-4	R169	C-3	RB512	C-7
C058	F-7	C305	G-3	FB301	G-4	R170	C-3	RB514	D-7
C061	F-6	C306	G-3			R171	C-3		
C062	F-6	C307	G-4	IC101	B-4	R173	C-3	T001	F-8
C105	B-5	C308	G-6	IC151	D-4	R174	C-3		
C108	B-4	C309	G-4	IC272	F-3	R176	C-3	X501	C-7
C109	B-5	C310	E-5	IC301	G-5	R177	E-3	X502	C-8
C110	B-5	C311	F-4	IC302	G-4	R178	E-2		
C111	B-5	C312	G-3	IC503	D-7	R179	E-2		
C113	B-4	C313	G-3			R180	E-3		
C114	B-5	C314	F-4	L001	G-8	R181	E-3		
C115	B-5	C315	G-3	L002	F-8	R182	E-3		
C116	B-4	C316	G-6	L004	G-8	R183	E-3		
C117	B-5	C317	F-4	L005	G-9	R184	E-3		
C118	B-4	C318	F-4	L006	F-9	R185	D-3		
C119	B-4	C319	G-4	L007	G-8	R186	D-3		
C121	B-5	C352	B-1	L008	G-7	R187	D-3		
C122	B-4	C353	B-1	L009	F-7	R188	D-3		
C124	B-4	C354	A-3	L010	F-7	R189	D-3		
C125	B-5	C357	B-2	L012	F-7	R190	D-3		
C126	B-5	C359	B-3	L013	G-7	R191	D-3		
C127	B-5	C361	A-1	L014	G-7	R192	D-3		
C128	B-4	C362	A-1	L016	F-7	R193	C-3		
C129	B-4	C365	A-2	L151	D-2	R197	E-3		
C130	B-5	C366	B-3	L154	F-3	R198	E-3		
C131	C-5	C367	A-2	L271	E-4	R199	C-4		
C132	B-5	C374	A-3	L301	G-6	R200	C-4		
C133	B-5	C403	B-7	L303	F-4	R204	E-2		
C135	B-4	C404	B-7	L705	D-1	R206	C-4		
C136	B-4	C458	B-8			R208	C-5		
C152	D-3	C459	B-8	Q001	E-7	R218	C-4		
C154	E-2	C461	B-8	Q002	E-9	R229	D-1		
C156	C-3	C462	B-8	Q003	E-8	R301	G-4		
C157	C-3	C503	E-7	Q004	E-8	R302	G-4		
C158	C-3	C504	E-7	Q101	A-5	R304	G-3		
C160	D-2	C511	E-7	Q102	B-5	R306	G-3		
C161	C-3	C512	E-7	Q103	B-5	R307	G-4		
C162	E-3	C513	C-7	Q104	B-5	R308	G-4		
C163	E-3	C514	D-8	Q152	E-3	R309	G-3		
C164	E-3	C515	C-9	Q153	E-3	R310	G-3		
C165	E-3	C516	C-8	Q154	D-3	R311	G-4		
C166	D-3	C517	D-8	Q155	D-3	R312	G-3		
C167	D-3	C519	C-7	Q156	D-3	R313	G-4		
C168	D-3	C701	C-2	Q157	D-3	R314	G-4		
C169	D-3			Q158	E-2	R316	G-4		
C170	C-3	CN001	D-9	Q301	G-3	R317	G-4		
C171	C-3	CN101	A-4	Q302	G-5	R318	F-4		
C172	C-3	CN271	F-5	Q303	F-3	R319	F-3		
C173	C-3	CN301	G-4	Q701	E-6	R321	F-3		
C174	C-3	CN701	C-2			R322	F-3		
C175	C-3	CN704	A-2	R003	D-8	R323	G-3		
C177	C-3	CN706	A-6	R008	E-8	R354	A-1		
C184	E-3	CN707	A-7	R010	E-8	R355	A-1		
C185	E-4	CN708	E-6	R013	E-8	R358	A-1		
C186	C-3	CN709	B-6	R017	E-8	R359	A-1		
C187	C-4	CN710	G-7	R018	E-8	R402	B-7		
C188	C-4	CN711	C-9	R022	E-7	R451	D-8		
C189	E-3	CN712	A-8	R052	E-8	R452	E-8		
C190	E-4	CN713	D-6	R101	A-5	R455	A-7		
C192	C-5	CN715	D-6	R102	A-5	R457	A-8		
C194	C-5			R105	B-5	R513	D-7		
C201	C-3	D001	D-8	R107	B-5	R516	C-7		
C223	C-2	D002	D-8	R108	B-5	R518	E-7		
C233	B-2	D004	D-8	R112	B-5	R519	E-7		
C247	B-2	D005	D-8	R113	B-5	R520	E-7		
C248	B-3	D301	G-3	R115	B-5	R521	E-7		
C249	C-1	D501	E-7	R116	B-4	R525	C-8		
C250	B-1	D505	E-7	R117	B-5	R542	C-8		
C252	B-3			R118	B-4	R543	C-7		
C280	F-4	ET001	G-7	R120	B-5	R544	C-8		
C281	F-4	ET002	G-9	R121	B-4	R552	C-8		
C286	F-3	ET101	B-5	R122	B-4	R554	D-8		
C287	F-3	ET102	B-4	R154	C-3	R558	D-8		
C288	F-3			R155	C-3	R709	D-6		
C289	F-3	F001	D-9	R156	E-2	R710	D-6		

**CCD-TR618/TR618E/TR718E/TR728E/TR818/TRV49/TRV49E/TRV58/
TRV58E/TRV59E/TRV68/TRV78/TRV78E/TRV88/TRV98/TRV98E**

VC-251 BOARD (SIDE B)

C001	E-12	C283	F-16	C518	D-10	Q353	A-18	R401	B-12
C002	E-12	C284	E-14	C601	D-15	Q354	A-17	R403	C-11
C003	E-12	C285	E-15	C602	D-15	Q355	A-18	R404	C-12
C004	E-12	C351	B-18	C603	D-16	Q451	A-11	R408	C-12
C005	E-12	C355	B-17	C707	E-17	Q501	D-10	R411	C-12
C008	E-12	C356	B-17	C708	E-18	Q702	E-18	R417	B-13
C009	E-12	C358	B-17			Q703	E-17	R420	B-13
C011	E-11	C363	A-18	CN702	E-18	Q704	D-18	R423	B-13
C012	E-13	C364	B-17	CN703	B-18	Q705	D-18	R428	B-13
C013	E-11	C368	B-17	CN714	C-10			R430	C-13
C014	E-13	C369	A-17			R001	E-12	R431	B-13
C015	E-11	C371	A-17	D006	F-12	R002	E-12	R432	C-13
C016	F-11	C372	A-17	D007	F-11	R004	E-11	R433	B-13
C017	E-11	C373	A-17	D010	F-12	R006	E-13	R434	A-12
C018	F-13	C375	B-17	D151	C-16	R007	E-12	R458	B-11
C019	F-13	C376	A-17	D152	C-16	R009	E-13	R459	B-11
C021	F-12	C377	A-17	D271	F-15	R011	E-11	R460	B-11
C022	F-12	C378	A-17	D272	E-16	R012	E-13	R461	B-10
C023	F-12	C379	A-17	D451	B-10	R014	E-11	R462	C-10
C024	F-12	C380	B-17	D503	E-10	R016	E-13	R464	A-12
C026	G-11	C381	A-17	D504	D-11	R020	E-11	R465	A-12
C027	G-11	C382	B-17	D702	D-18	R021	E-11	R466	B-10
C028	G-10	C383	A-16	D703	F-18	R023	E-11	R467	B-10
C029	F-10	C384	A-16			R025	F-10	R468	B-11
C030	G-11	C385	B-16	FB152	E-16	R026	F-11	R469	A-11
C031	F-11	C386	A-16	FB153	E-14	R027	F-11	R470	B-10
C032	G-11	C387	B-16	FB221	C-18	R028	G-12	R471	A-11
C033	G-11	C388	B-16	FB271	F-15	R029	F-11	R472	A-11
C034	F-11	C389	A-16	FB273	F-16	R030	G-12	R474	A-10
C035	F-10	C390	B-16	FB274	F-16	R031	G-12	R480	A-10
C036	F-10	C391	B-16	FB276	F-16	R032	G-12	R481	A-11
C037	G-11	C392	B-16	FB601	D-16	R033	F-10	R501	D-10
C039	G-11	C393	B-16			R034	F-11	R502	E-10
C042	G-12	C394	A-16	IC001	E-12	R035	G-13	R503	E-10
C043	F-12	C395	B-16	IC153	E-14	R036	G-12	R504	D-10
C047	G-12	C396	B-16	IC221	C-18	R037	G-12	R531	C-12
C048	F-12	C397	B-16	IC271	F-15	R038	G-13	R547	C-11
C052	F-10	C398	B-17	IC351	B-17	R039	G-12	R559	D-11
C053	G-13	C401	C-11	IC401	C-11	R040	G-12	R611	B-13
C054	G-13	C402	B-12	IC402	B-12	R041	G-13	R612	B-13
C055	G-12	C405	C-12	IC451	B-11	R042	G-12	R613	C-13
C057	F-13	C406	C-13	IC502	E-11	R043	G-12	R614	B-13
C059	F-10	C407	C-13	IC504	E-11	R044	G-12	R701	E-17
C060	E-12	C408	B-13	IC601	D-15	R045	G-12	R702	E-17
C071	F-13	C409	A-13			R046	G-12	R703	E-17
C072	F-13	C410	B-13	L003	G-11	R047	F-12	R704	D-18
C101	A-14	C411	B-13	L011	G-11	R048	G-12	R705	D-17
C102	A-15	C451	B-11	L101	A-15	R049	F-12	R706	D-18
C103	A-15	C452	B-11	L102	B-14	R050	G-13	R707	D-18
C104	B-14	C453	B-11	L103	B-15	R051	G-13	R708	D-18
C106	B-15	C454	B-11	L104	B-14	R071	F-13		
C107	B-14	C455	B-11	L152	E-16	R072	F-13	RB102	B-14
C112	B-14	C456	B-11	L155	C-16	R073	F-12	RB151	C-15
C123	B-14	C457	B-11	L156	C-16	R074	F-13	RB273	F-16
C134	B-14	C460	A-12	L221	C-17	R106	B-14	RB351	A-17
C151	C-16	C463	B-11	L224	C-18	R109	B-15	RB352	A-17
C155	C-15	C464	A-11	L272	F-16	R110	B-15	RB401	A-12
C176	D-16	C465	B-10	L601	D-15	R111	B-14	RB402	C-13
C178	C-16	C466	B-10			R123	B-15	RB404	B-13
C179	C-16	C467	B-11	Q006	G-11	R124	B-15	RB405	B-13
C182	C-16	C468	B-10	Q007	F-11	R168	D-15	RB406	B-13
C183	C-16	C469	B-11	Q008	F-11	R172	C-15	RB407	A-13
C195	D-14	C470	B-10	Q009	G-10	R175	C-16	RB451	A-12
C196	E-14	C471	B-11	Q010	G-11	R195	C-16	RB452	A-11
C221	C-18	C472	B-10	Q011	G-10	R196	C-15	RB501	D-12
C225	C-17	C473	B-10	Q012	F-10	R226	D-17	RB502	D-12
C226	C-17	C474	A-11	Q013	G-11	R232	D-17	RB503	D-12
C227	C-17	C475	A-10	Q014	F-11	R271	F-15	RB504	D-12
C228	C-17	C476	A-10	Q015	F-10	R274	F-14	RB505	D-12
C231	D-18	C477	A-11	Q016	F-10	R275	F-15	RB506	D-12
C234	C-17	C478	A-11	Q018	G-12	R279	F-16	RB507	D-12
C235	D-17	C479	A-11	Q019	G-13	R280	E-15	RB508	E-12
C236	C-17	C480	A-11	Q020	G-12	R281	E-16	RB509	E-11
C238	C-18	C481	A-11	Q021	G-12	R351	B-18	RB511	D-11
C246	C-18	C482	A-11	Q022	G-13	R352	B-17	RB513	C-11
C251	C-18	C483	A-11	Q023	G-12	R353	B-17		
C271	F-15	C484	A-11	Q026	F-13	R356	B-17	VDR701	E-18
C272	F-15	C485	B-11	Q027	F-12	R363	B-18	VDR702	E-18
C273	F-15	C501	E-11	Q071	F-13	R364	A-18	VDR703	E-18
C274	F-15	C502	E-11	Q072	F-13	R368	B-17	VDR704	E-18
C275	F-15	C505	E-12	Q105	B-14	R372	B-17	VDR706	E-18
C276	F-15	C506	E-12	Q106	B-15	R373	A-16	VDR707	E-18
C277	F-15	C507	E-12	Q107	B-14	R374	B-16		
C278	F-15	C508	E-12	Q151	C-15	R379	B-16	X271	E-16
C279	F-15	C509	E-12	Q351	A-18	R381	E-18	X401	B-12
C282	F-15	C510	E-12	Q352	A-18	R382	E-18		

**SECTION 5
ADJUSTMENTS**

1. Before starting adjustment

1-1. Adjusting items when replacing main parts and boards.

When replacing main parts, adjust the items indicated by ● in the following table.

Adjustment Section	Adjustment	Replaced parts																								
		Block replacement								Parts replacement																
		Lens device	Video light *8	LCD block	LCD block	B/W EVF block	Color EVF block	Mechanism deck *1	Mechanism deck	Mechanism deck	CD-286/281 board	VC-251 board	VC-251 board	VC-251 board	VC-251 board	VC-251 board	MI-040/041 board	MI-040/041 board	PD-131 board	PD-131 board	VF-129 board	VF-129 board	VF-141 board	VF-141 board	LB-62 board	
Initialization of D, E, F, 7 page data	Initialization of D, E, F, 7 page data Modification of D, E, F, 7 page data																									
Camera	Lens type input	●																								
	HALL adj.	●																								
	Flange back adj.	●								●																
	Color reproduction adj.									●		●														
	AWB & LV standard data input									●		●														
	Auto white balance adj.									●		●														
	Angular velocity sensor sens. adj. *6																●									
Color EVF *2	VCO adj.																								●	
	RGB AMP adj.																							●		
	Contrast adj.																							●		
	Backlight consumption current adj.																							●		●
	White balance adj.						●																	●		●
B/W EVF *3	Centering adj.				●																	●				
	Focus adj.				●																	●				
	Aberration adj.				●																	●				
	Horizontal amplitude adj.				●																	●				
	Vertical amplitude adj.				●																	●				
	Brightness adj.				●																	●				
LCD *4	VCO adj.																								●	
	RGB AMP adj.																									
	Contrast adj.																									
	COM-AMP adj.																									
	V-COM adj.																									
	White balance adj.		●	●																						
Servo	CAP FG offset adj.							●	●																	
	Switching position adj.							●	●																	
Video	28MHz origin oscillation adj.									●																
	AFC fo adj.																									
	Filter fo adj.																									
	Y OUT level adj.																									
	C OUT level adj.																									
	REC Y current adj.																									
	REC C/AFM current adj.																									
IR *5	IR video carrier frequency adj.																									
	IR video deviation adj.																									
	IR audio deviation adj.																									
Audio	1.5MHz deviation adj.																									
	BPF fo adj.																									
Mechanism	Tape path adj.																									

Table. 5-1-1(1).

Adjustment Section	Adjustment	Board replacement					EEPROM
		VC-251 board (COMPLETE)	MI-040/041 board (COMPLETE) *7	PD-131 board (COMPLETE) *4	VF-129 board (COMPLETE) *3	VF-141 board (COMPLETE) *2	
Initialization of D, E, F, 7 page data	Initialization of D, E, F, 7 page data						●
	Modification of D, E, F, 7 page data	●					●
Camera	Lens type input	●					●
	HALL adj.	●					●
	Flange back adj.	●					●
	Color reproduction adj.	●					●
	AWB & LV standard data input	●					●
	Auto white balance adj.	●					●
	Angular velocity sensor sens. adj. *6	●	●				●
Color EVF *2	VCO adj.	●				●	●
	RGB AMP adj.	●				●	●
	Contrast adj.	●				●	●
	Backlight consumption current adj.	●				●	●
	White balance adj.	●				●	●
B/W EVF *3	Centering adj.				●		
	Focus adj.				●		
	Aberration adj.				●		
	Horizontal amplitude adj.				●		
	Vertical amplitude adj.				●		
	Brightness adj.				●		
LCD *4	VCO adj.	●	●				●
	RGB AMP adj.	●	●				●
	Contrast adj.	●	●				●
	COM-AMP adj.	●	●				●
	V-COM adj.	●	●				●
	White balance adj.	●	●				●
Servo	CAP FG offset adj.	●					●
	Switching position adj.	●					●
Video	28MHz origin oscillation adj.						●
	AFC fo adj.						●
	Filter fo adj.						●
	Y OUT level adj.						●
	C OUT level adj.						●
	REC Y current adj.						●
	REC C/AFM current adj.						●
IR *5	IR video carrier frequency adj.		●				●
	IR video deviation adj.		●				●
	IR audio deviation adj.		●				●
Audio	1.5MHz deviation adj.						●
	BPF fo adj.						●
Mechanism	Tape path adj.						●

*1: When replacing the drum assy. or mechanism deck, reset the data of page: 2, address: A2 to A4 to "00". (Refer to "Record of Use check" of "5-4. SERVICE MODE")

*2: Color EVF model (CCD-TR818)

*3: B/W EVF model (CCD-TR618/TR618E/TR718E/TR728E/TRV49/TRV49E/TRV58/TRV58E/TRV59E/TRV68/TRV78/TRV78E/TRV88/TRV98/TRV98E)

*4: TRV model: (CCD-TRV49/TRV49E/TRV58/TRV58E/TRV59E/TRV68/TRV78/TRV78E/TRV88/TRV98/TRV98E)

*5: LASER LINK model (CCD-TRV98)

*6: Steady shot model (CCD-TR818/TRV68/TRV78/TRV78E/TRV88/TRV98/TRV98E)

*7: MI-040 board: TR model

MI-041 board: TRV model

*8: When replacing the video light, reset the data of page: 2, address: E0 to E2 to "00". (Except for CCD-TR818)

Table. 5-1-1(2).

5-1. CAMERA SECTION ADJUSTMENT

1-1. PREPARATIONS BEFORE ADJUSTMENT (CAMERA SECTION)

1-1-1. List of Service Tools

- Oscilloscope
- Color monitor
- Vectorscope
- Regulated power supply
- Digital voltmeter

Ref. No.	Name	Parts Code	Usage
J-1	Filter for color temperature correction (C14)	J-6080-058-A	Auto white balance adjustment/check White balance adjustment/check
J-2	ND filter 1.0	J-6080-808-A	White balance check
	ND filter 0.4	J-6080-806-A	White balance check
	ND filter 0.1	J-6080-807-A	White balance check
J-3	Pattern box PTB-450	J-6082-200-A	
J-4	Color chart for pattern box	J-6020-250-A	
J-5	Adjustment remote commander (RM-95 upgraded) (Note)	J-6082-053-B	
J-6	Siemens star chart	J-6080-875-A	For checking the flange back
J-7	Clear chart for pattern box	J-6080-621-A	
J-8	Multi CPC jig	J-6082-311-A	For adjusting the LCD block
J-9	CPC jig for BX/BK	J-6082-521-A	For connecting the adjustment remote commander
J-10	IR receiver jig	J-6082-383-A	For adjusting the IR transmitter
J-11	Minipattern box	J-6082-353-B	For adjusting the flange back
J-12	Camera base	J-6082-384-A	For adjusting the flange back

Note: If the micro processor IC in the adjustment remote commander is not the new micro processor (UPD7503G-C56-12), the pages cannot be switched. In this case, replace with the new micro processor (8-759-148-35).

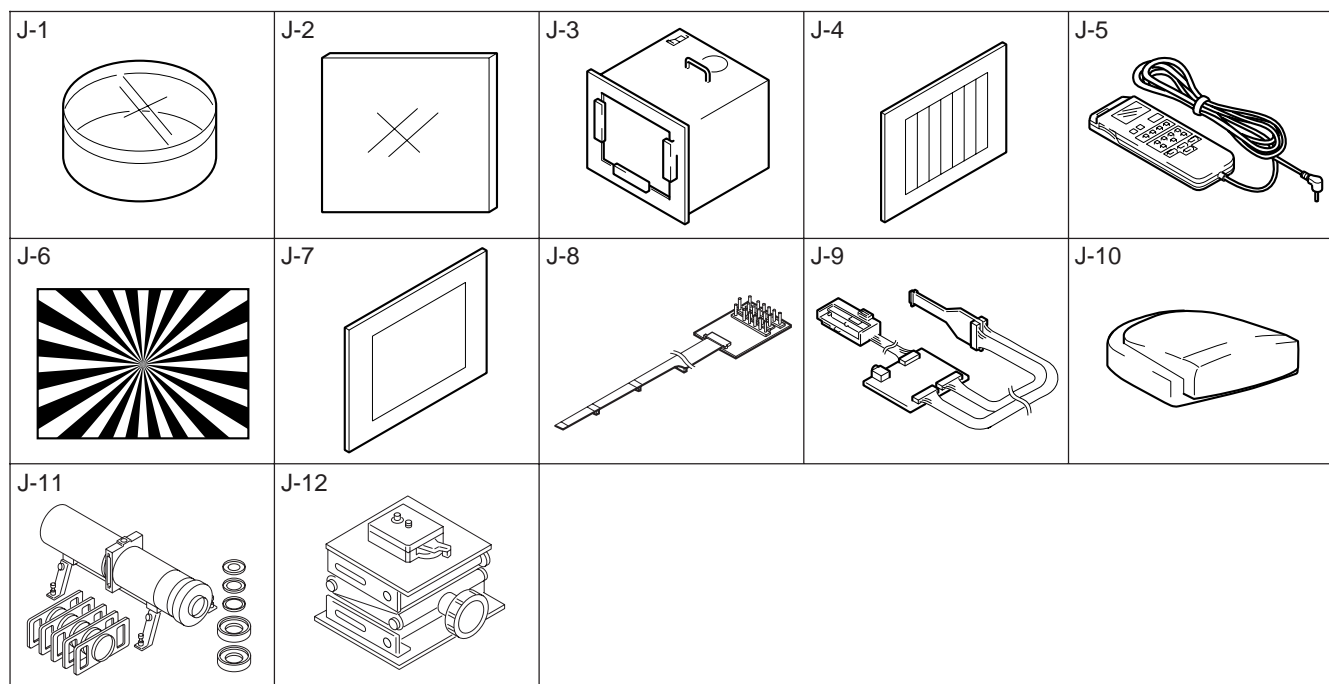

Fig. 5-1-1.

1-1-2. Preparations

Note1: For details of how remove the cabinet and boards, refer to “2. DISASSEMBLY”.

Note2: When performing only the adjustments, the lens block and boards need not be disassembled.

Note3: CF-077 board, MI-040 board: TR model
 CF-1000 block, MI-041 board: TRV model
 TR model: CCD-TR618/TR618E/TR718E/TR728E/TR818
 TRV model: CCD-TRV49/TRV49E/TRV58/TRV58E/TRV59E/
 TRV68/TRV78/TRV78E/TRV88/TRV98/TRV98E

- 1) Connect the equipment for adjustments according to Fig. 5-1-4, 5-1-5.
- 2) Connect the adjustment remote commander to CN713 of VC-251 board or CPC connector of FP-262 flexible via CPC jig for BX/BK (J-6082-521-A). To operate the adjustment remote commander, connect the AC power adapter to the DC IN jack of CPC jig for BX/BK, or connect the L series Info-LITHIUM battery to the battery terminal of CPC jig for BX/BK. (Fig. 5-1-3.)
- 3) The front panel block (MI-040/041 board, microphone unit, video light) need not be assembled except during the steady shot operation check.

Note4: As removing the cabinet (R) (removing the VC-251 board CN709) means removing the lithium 3V power supply (CF-1000 block/CF-077 board BT101), data such as date, time, user-set menus will be lost. After completing adjustments, reset these data. If the cabinet (R) has been removed, the self-diagnosis data, data on history of use (total drum rotation time etc.) will be lost. Before removing, note down the self-diagnosis data (data of page: 2, address: B0 to C6 and E0 to E2) and data on history use (data of page: 2, address: A2 to AA). (Refer to “5-4. Service Mode” for the self-diagnosis data and data on the history use.)

Note5: Setting the “Forced Camera Power ON” Mode
 1) Select page: 0, address: 01, and set data: 01.
 2) Select page: D, address: 10, set data: 01, and press the PAUSE button.
 The above procedure will enable the camera power to be turned on with the SS-1000 block removed. After completing adjustments, be sure to exit the “Forced Camera Power ON Mode”.

Note6: Exiting the “Forced Camera Power ON” Mode
 1) Select page: 0, address: 01, and set data: 01.
 2) Select page: D, address: 10, set data: 00, and press the PAUSE button.
 3) Select page: 0, address: 01, and set data: 00.

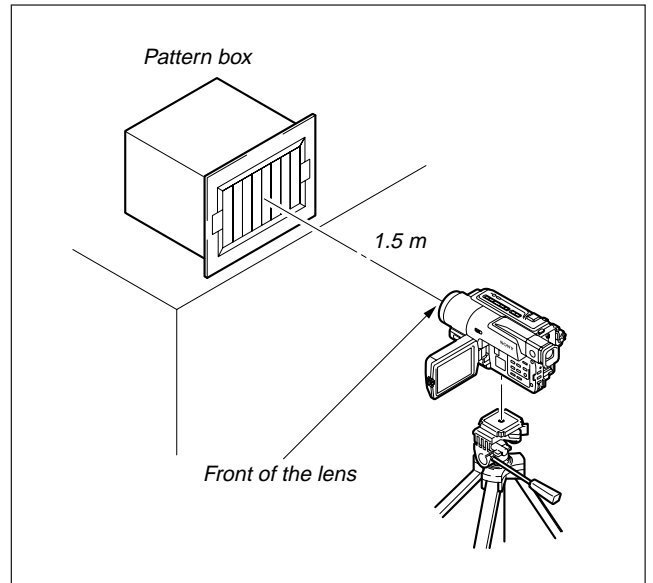
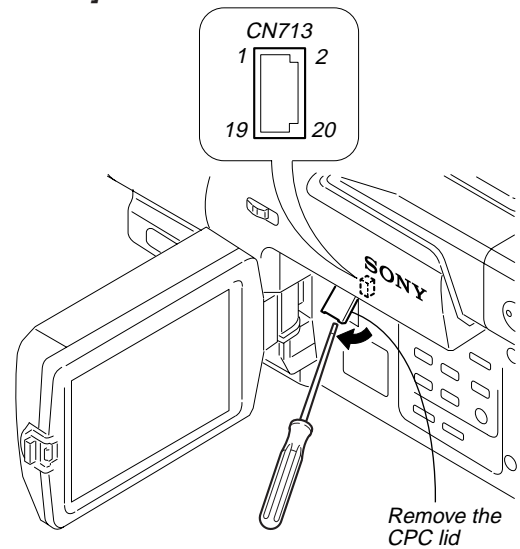

Fig. 5-1-2.

[TRV model]



[TR model]

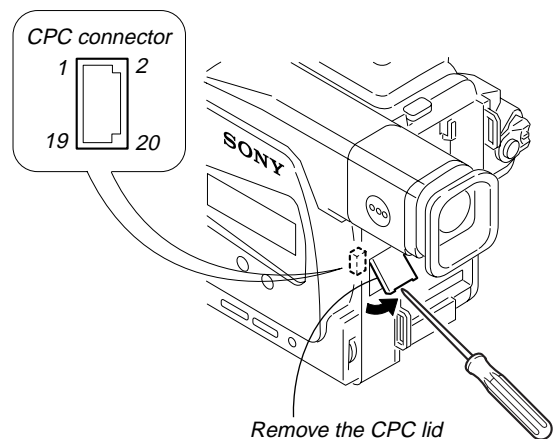

Fig. 5-1-3.

TR model (CCD-TR618/TR618E/TR718E/TR728E/TR818)

Note: Use either a AC power adaptor or a Info-LITHIUM battery as the power supply of the CPC jig for BX/BK.

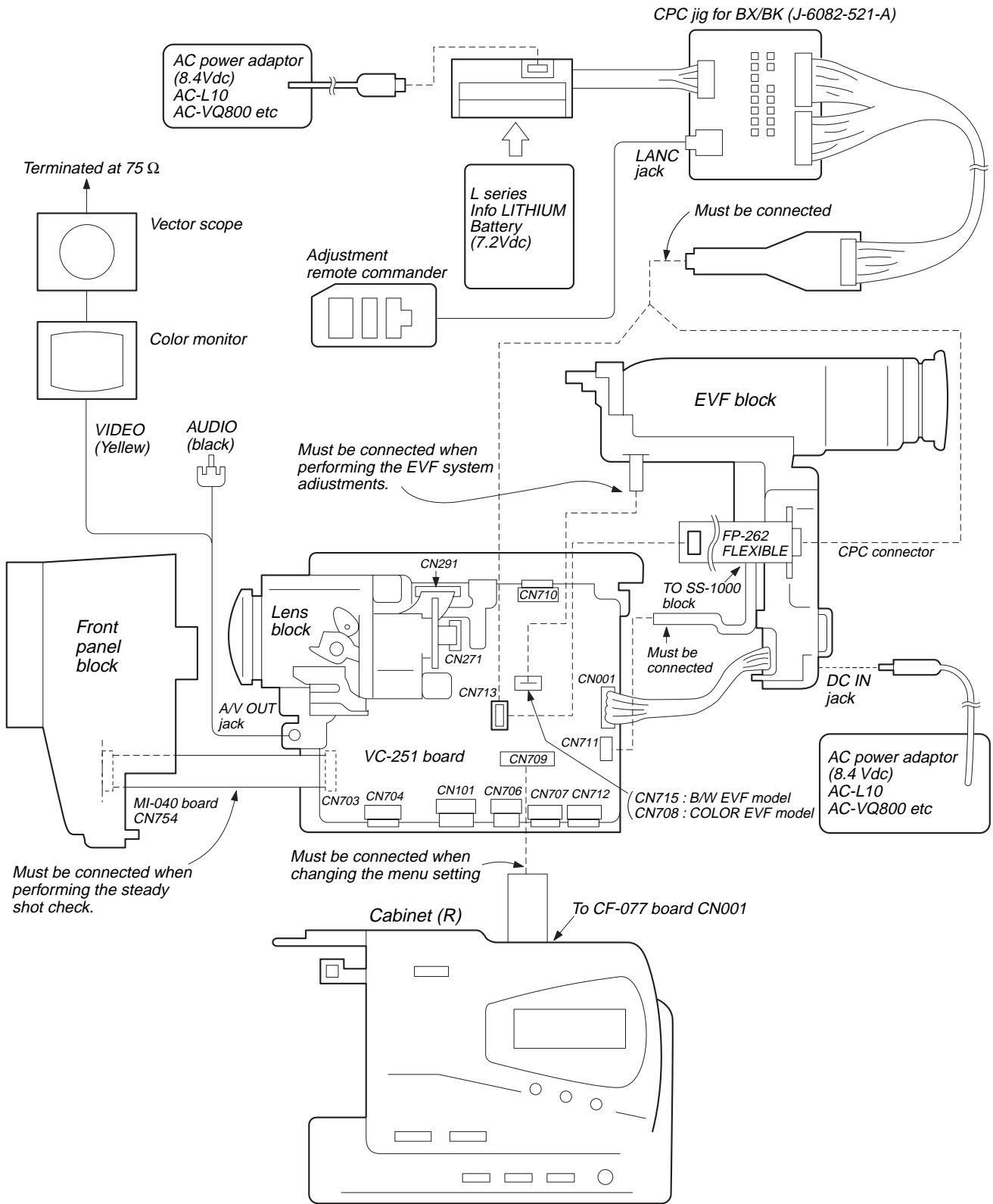

Fig. 5-1-4.

TRV model (CCD-TRV49/TRV49E/TRV58/TRV58E/TRV59E/TRV68/TRV78/TRV78E/TRV88/TRV98/TRV98E)

Note: Use either a AC power adaptor or a Info-LITHIUM battery as the power supply of the CPC jig for BX/BK.

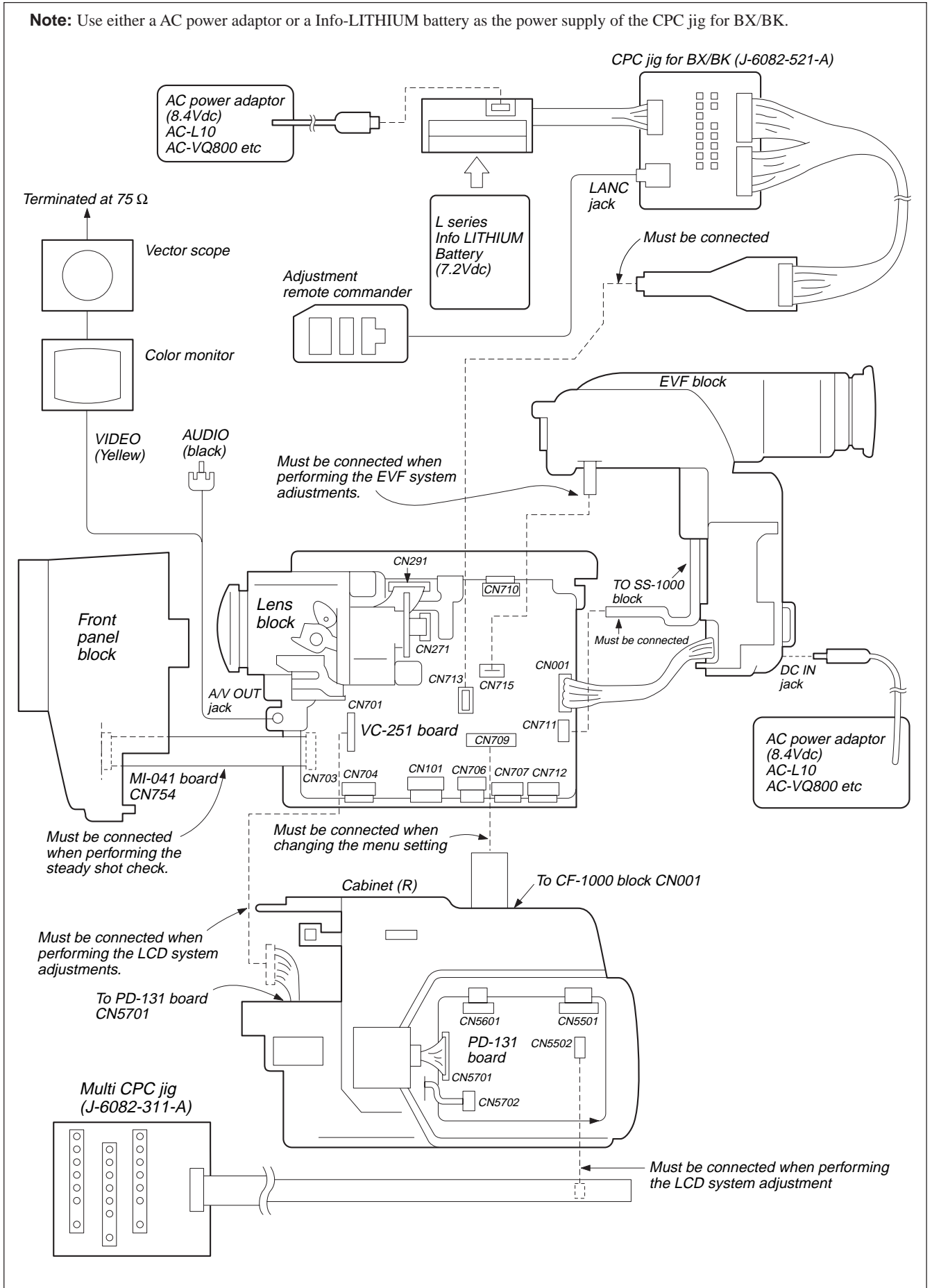

Fig. 5-1-5.

1-1-3. Precaution

1. Setting the Switch

Unless otherwise specified, set the switches as follows and perform adjustments without loading cassette.

- | | | | |
|--|-----------|---|--------|
| 1. POWER switch (SS-1000 block) | CAMERA | 8. DISPLAY (CF-1000 block) *3 | ON |
| 2. NIGHT SHOT switch (Lens block) | OFF | 9. FOCUS switch (CF-1000 block/CF-077 board) ... | MANUAL |
| 3. LIGHT switch (FK-1000 block) *1 | OFF | 10. BACK LIGHT (CF-1000 block/CF-077 board) | OFF |
| 4. DEMO MODE (Menu display) | OFF | 11. PROGRAM AE (Menu display) | OFF |
| 5. DIGITAL ZOOM (Menu display) | OFF | 12. PICTURE EFFECT (Menu display) | OFF |
| 6. STEADY SHOT (Menu display) *2 | OFF | 13. 16 : 9 WIDE (MENU display) | OFF |
| 7. DISPLAY (Menu display) *3 | V-OUT/LCD | | |

*1: Video light model (CCD-TR618/TR618E/TR718E/TR728E/TR818/TRV49/TRV49E/TRV58/TRV58E/TRV59E/TRV68/TRV78/TRV78E/TRV88/TRV98/TRV98E)

*2: Steady shot model (CCD-TR818/TRV68/TRV78/TRV78E/TRV88/TRV98/TRV98E)

*3: TRV model (CCD-TRV49/TRV49E/TRV58/TRV58E/TRV59E/TRV68/TRV78/TRV78E/TRV88/TRV98/TRV98E)

2. Order of Adjustments

Basically carry out adjustments in the order given.

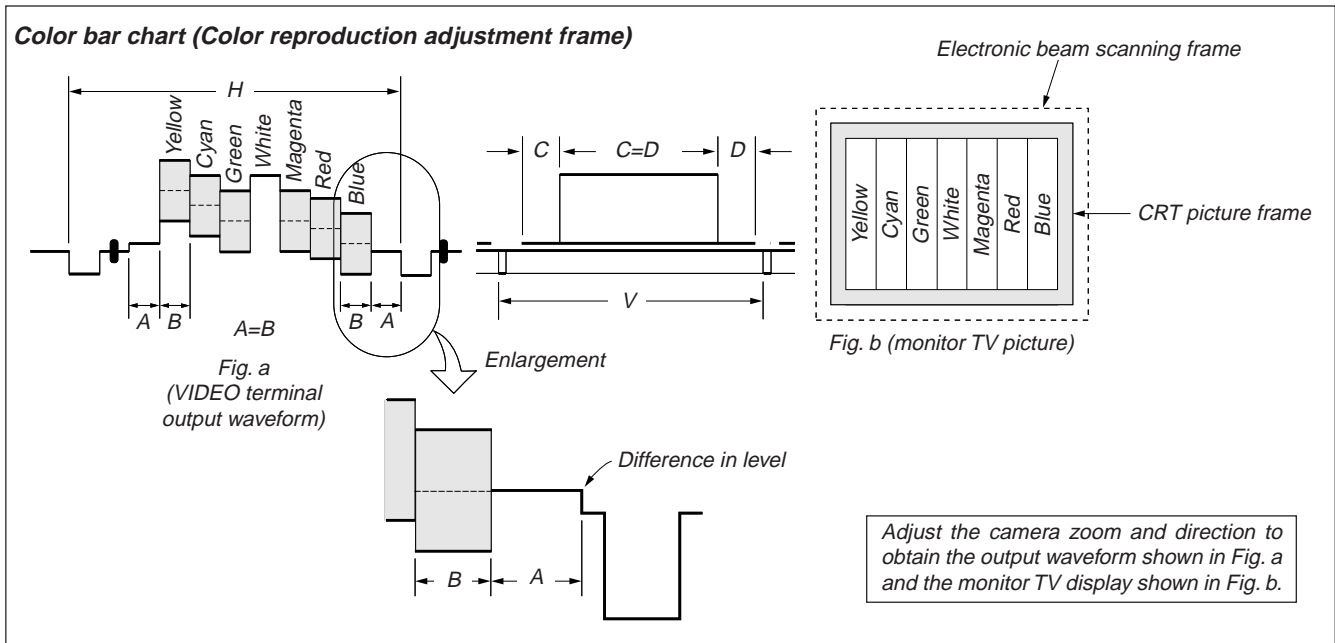

Fig.5-1-6.

3. Subjects

- 1) Color bar chart (Color reproduction adjustment frame)
When performing adjustments using the color bar chart, adjust the picture frame as shown in Fig. 5-1-6. (Color reproduction adjustment frame)
- 2) Clear chart (Color reproduction adjustment frame)
Remove the color bar chart from the pattern box and insert a clear chart in its place. (Do not perform zoom operations during this time.)
- 3) Flange back adjustment chart
Make the chart shown in Fig. 5-1-7 using A0 size (1189mm x 841mm) black and white vellum paper.

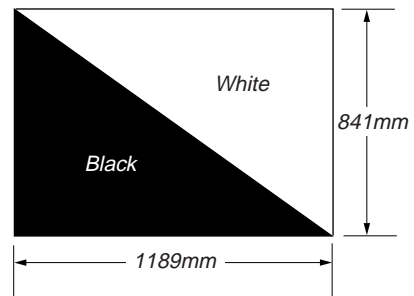

Fig. 5-1-7.

Note: Use matte vellum paper bigger than A0, and make sure the edges of the black and white paper joined together are not rough.

1-2. INITIALIZATION OF D, E, F, 7 PAGE DATA

1. Initializing the D, E, F, 7 Page Data

Note1: If “Initializing the D, E, F, 7 Page Data” is performed, all data of the D page, E page, F page and 7 page will be initialized. (It is impossible to initialize a single page.)

Note2: If the D, E, F, 7 page data has been initialized, “Modification of D, E, F, 7 Page Data” and all adjustments need to be performed again.

Adjustment page	D
Adjustment Address	10 to FF
Adjustment page	F
Adjustment Address	10 to FF
Adjustment page	E
Adjustment Address	00 to FF
Adjustment page	7
Adjustment Address	00 to FF

Note: NTSC model: CCD-TR618/TR818/TRV49/TRV58/TRV68/TRV78/TRV88/TRV98
PAL model: CCD-TR618E/TR718E/TR728E/TRV49E/TRV58E/TRV59E/TRV78E/TRV98E

Initializing Method:

Order	Page	Address	Data	Procedure
1	0	01	01	Set the data.
2	6	00		Set the following data. 55: NTSC model 51: PAL model
3	6	01		Set the following data, and press PAUSE button. 55: NTSC model 51: PAL model
4	6	02		Check that the data changes to “01”.
5	2	00	29	Set the data
6	2	01	29	Set the data, and press PAUSE button.
7				Perform “Modification of D, E, F, 7 Page Data”.

2. Modification of D, E, F, 7 Page Data

If the D, E, F, 7 page data has been initialized, change the data of the “Fixed data-2” address shown in the following tables by manual input.

Modifying Method:

- Before changing the data, select page: 0, address: 01, and set data: 01.
- New data for changing are not shown in the tables because they are different in destination. When changing the data, copy the data built in the same model.
Note: If copy the data built in the different model, the camcorder may not operate.
- When changing the data, press the PAUSE button of the adjustment remote commander each time when setting new data to write the data in the non-volatile memory.
- Check that the data of adjustment addresses is the initial value. If not, change the data to the initial value.

Processing after Completing Modification of D, E, F, 7 Page data

Order	Page	Address	Data	Procedure
1	2	00	29	Set the data
2	2	01	29	Set the data, and press PAUSE button.

Note: If the following symptoms occur after completing of the “Modification of D, E, F, 7 page data”, check that the data of the “Fixed data-2” addresses of D page are same as those of the same model of the same destination.

- The battery end mark on the LCD or viewfinder screen is flashing.
- The power is shut off so that unit cannot operate.

3. D Page Table

Note1: Fixed data-1: Initialized data. (Refer to “1. Initializing the D, E, F, 7 Page Data”.)
Fixed data-1: Modified data. (Refer to “2. Modification of D, E, F, 7 Page Data”.)

Address	Initial value		Remark
	NTSC	PAL	
00 to 0F			
10	00	00	Test mode
11 to 12			Fixed data-1
13			Fixed data-2
14			Fixed data-1
15			Fixed data-2
16 to 19			Fixed data-1
1A			Fixed data-2
1B to 1E			Fixed data-1
1F			Fixed data-2
20			(Modified data. Copy the data built in the same model.)
21			
22			
23			
24 to 26			Fixed data-1
27			Fixed data-2
28 to 2C			Fixed data-1
2D			Fixed data-2
2E			(Modified data. Copy the data built in the same model.)
2F			
30			
31 to 3F			
40			Fixed data-2
41			(Modified data. Copy the data built in the same model.)
42			
43			
44			
45			
46 to 47			Fixed data-1
48			Fixed data-2
49			
4A to 4C			Fixed data-1
4D			Fixed data-2
4E			
4F			Fixed data-1
50			Fixed data-2
51			(Modified data. Copy the data built in the same model.)
52			

Address	Initial value		Remark
	NTSC	PAL	
53			Fixed data-1
54			Fixed data-2
55 to 57			Fixed data-1
58			Fixed data-2
59			(Modified data. Copy the data built in the same model.)
5A			
5B			
5C			
5D to 63			Fixed data-1
64			Fixed data-2
65			(Modified data. Copy the data built in the same model.)
66			
67			
68			
69 to 87			Fixed data-1
88			Fixed data-2
89			(Modified data. Copy the data built in the same model.)
8A			
8B			
8C to FF			Fixed data-1

Table. 5-1-2.

4. F Page table

Note1: Fixed data-1: Initialized data. (Refer to “1. Initializing the D, E, F, 7 Page Data”.)

Fixed data-2: Modified data. (Refer to “2. Modification of D, E, F, 7 Page Data”.)

Address	Initial value		Remark	
	NTSC	PAL		
00 to 0F				
10	00	00	Emergency memory address	
11	00	00		
12	00	00		
13	00	00		
14	00	00		
15	00	00		
16	00	00		
17	00	00		
18	00	00		
19	00	00		
1A	00	00		
1B	00	00		
1C				Fixed data-1
1D				Fixed data-2
1E to 22			Fixed data-1	
23			Fixed data-2	
24				
25			Fixed data-1	
26			Fixed data-2	
27 to 2B			Fixed data-1	
2C	D7	D7	Lens type input	
2D to 32			Fixed data-1	
33			Fixed data-2	
34 to 37			Fixed data-1	
38	68	68	HALL adj.	
39	80	80		
3A	8D	8D		
3B			Fixed data-2	
3C	80	80	AWB & LV standard data input	
3D	7A	7A		
3E	2B	2B		
3F	80	80		
40	65	65		
41	80	80		
42	8D	8D	Auto white balance adj.	
43	87	87		
44 to 46			Fixed data-1	
47	33	33	Color reproduction adj.	
48			Fixed data-1	
49	34	34	Color reproduction adj.	
4A			Fixed data-1 (Initialized data)	
4B				
4C				
4D	8C	8C	28MHz origin osc. Adj.	
4E	28	28	Flange back adj.	
4F	07	07		
50	3A	3A		
51	4A	4A		
52	12	12		

Address	Initial value		Remark	
	NTSC	PAL		
53	0B	0B	Flange back adj.	
54	54	54		
55	00	00		
56	19	19		
57	00	00		
58	37	37		
59	00	00		
5A	00	00		
5B	04	04		
5C	00	00		
5D	00	00		
5E	5A	74		Angular velocity sensor sens. adj.
5F	57	5D		*1
60				Fixed data-1
61	00	00	Flange back adj.	
62	0A	0A	Switching position adj.	
63	00	00		
64	83	83	CAP FG offset adj.	
65	50	50	AFC fo adj.	
66	77	77	Filter fo adj.	
67	62	62	Y OUT level adj.	
68	62	62	C OUT level adj.	
69			Fixed data-1	
6A	B4	D7	REC Y current adj.	
6B	B4	D7		
6C to 70			Fixed data-1	
71	A0	A0	REC C/AFM current adj.	
72 to 7A			Fixed data-1	
7B	A6	A6	1.5MHz deviation adj.	
7C			Fixed data-1	
7D	80	80	BPF fo adj.	
7E	41	41	IR video deviation Adj. *2	
7F	33	33	IR audio deviation Adj. *2	
80	C7	C7	IR video carrier freq. Adj. *2	
81 to 89			Fixed data-1	
8A			Fixed data-2	
8B to 8D			Fixed data-1	
8E			Fixed data-2	
8F				
90 to 99			Fixed data-1	
9A			Fixed data-2	
9B to 9F			Fixed data-1	
A0			Fixed data-2	
A1 to B7			Fixed data-1	
B8			Fixed data-2 (Modified data. Copy the data built in the same model.)	
B9				
BA				
BB				
BC to CC			Fixed data-1	
CD			Fixed data-2	
CE to D3			Fixed data-1	
D4			Fixed data-2	
D5 to D6			Fixed data-1	

Address	Initial value		Remark
	NTSC	PAL	
D7	FD	FC	Color reproduction adj.
D8	F4	F2	
D9	0F	11	
DA	31	33	
DB to DD			
DE			Fixed data-2
DF			
F0 to F2			Fixed data-1
F3			Fixed data-2
F4			
F5			Fixed data-1
F6			Fixed data-2
F7 to FF			Fixed data-1

*1: Steady shot model (CCD-TR818/TRV68/TRV78/TRV78E/TRV88/TRV98/TRV98E)

*2: LASER LINK model (CCD-TRV98)

Table. 5-1-3.

5. E Page Table

Note: Fixed data-1: Initialized data. (Refer to “1. Initializing the D, E, F, 7 Page Data”.)

Fixed data-2: Modified data. (Refer to “2. Modification of D, E, F, 7 Page Data”.)

Address	Initial value		Remark
	NTSC	PAL	
00 to 01			Fixed data-1
02			Fixed data-2
03			(Modified data. Copy the data built in the same model.)
04			
05			
06			
07			Fixed data-1
08			Fixed data-2
09			
0A to 0E			Fixed data-1
0F			Fixed data-2
10			(Modified data. Copy the data built in the same model.)
11			
12			
13			
14			
15 to 17			Fixed data-1
18			Fixed data-2
19			
1A to 27			Fixed data-1
28			Fixed data-2
29 to 2F			Fixed data-1
30			Fixed data-2
31 to 33			Fixed data-1
34			Fixed data-2
35			Fixed data-1
36			Fixed data-2
37			Fixed data-1
38			Fixed data-2
39			
3A			Fixed data-1
3B			Fixed data-2
3C			
3D to 50			Fixed data-1
51			Fixed data-2
52 to 53			Fixed data-1
54			Fixed data-2
55			
56			Fixed data-1
57			Fixed data-2
58			Fixed data-1
59			Fixed data-2
5A to 5B			Fixed data-1
5C	22	22	Lens type input
5D	51	51	
5E	FD	FD	
5F	C4	C4	
60 to 71			Fixed data-1
72			Fixed data-2
73 to 7B			Fixed data-1

Address	Initial value		Remark
	NTSC	PAL	
7C			Fixed data-2
7D			(Modified data. Copy the data built in the same model.)
7E			
7F			Fixed data-1
80			Fixed data-2
81 to 8B			Fixed data-1
8C			Fixed data-2
8D			
8E to 8F			Fixed data-1
90			Fixed data-2
91 to B7			Fixed data-1
B7			Fixed data-2
B8 to BA			Fixed data-1
BB			Fixed data-2
BC to FB			Fixed data-1
FC			Fixed data-2
FD			
FE to FF			Fixed data-1

Table. 5-1-4.

6. 7 Page Table

Note: Fixed data-1: Initialized data. (Refer to “1. Initializing the D, E, F, 7 Page Data”.)

Fixed data-2: Modified data. (Refer to “2. Modification of D, E, F, 7 Page Data”.)

Address	Initial value		Remark
	NTSC	PAL	
00 to B4			Fixed data-1
B5			Fixed data-2
B6			
B7			Fixed data-1
B8			Fixed data-2
B9			(Modified data. Copy the data built in the same model.)
BA			
BB			
BC			Fixed data-1
BD			Fixed data-2
BE			(Modified data. Copy the data built in the same model.)
BF			
C0			
C1			Fixed data-1
C2			Fixed data-2
C3			
C4 to D4			Fixed data-1
D5			Fixed data-2
D6			Fixed data-1
D7			Fixed data-2
D8	A0	*1	RGB AMP adj. (Color EVF) *2
D9			Fixed data-1
DA	8D	*1	White balance adj. (Color EVF) *2
DB	83	*1	
DC	2F	*1	Contrast adj. (Color EVF) *2
DD			Fixed data-1
DE			Fixed data-2
DF	CA	*1	Back light consumption current adj. (Color EVF) *2
E0	07	*1	
E1	91	*1	
E2			Fixed data-1
E3			Fixed data-2
E4			
E5	6E	6E	VCO adj.(LCD) *3
E6	*1	63	VCO adj.(LCD) (PAL) *3
E7	8E	8E	V-COM adj.(LCD) *3
E8	29	29	RGB AMP adj.(LCD) *3
E9			Fixed data-1
EA	C3	C3	COM AMP adj.(LCD) *3
EB	60	60	White balance adj.(LCD) *3
EC	65	65	
ED	50	50	Contrast adj.(LCD) *3
EE			Fixed data-1
EF			Fixed data-2
F1 to F8			Fixed data-1
F9	FF	FF	REC Y current adj.
EA to FF			Fixed data-1

*1: Fixed data-1.

*2: Color EVF model (CCD-TR818)

*3: TRV model (CCD-TRV49/TRV49E/TRV58/TRV58E/TRV59E/TRV68/TRV78/TRV78E/TRV88/TRV98/TRV98E)

Table. 5-1-5.

3. Flange Back Adjustment (Using Minipattern Box)

The inner focus lens flange back adjustment is carried out automatically. In whichever case, the focus will be deviated during auto focusing/manual focusing.

Subject	Siemens star chart with ND filter for the minipattern box (Note1)
Measuring Instrument	Adjustment remote commander
Adjustment Page	F
Adjustment Address	4E to 5D, 61

Note1: Dark Siemens star chart.

Note2: Check that the data of page: 6, address: 02 is "00". If not, to page: 6, address: 01, set data: 00, and press the PAUSE button.

Note3: 1/4 CCD model: CCD-TR818/TRV68/TRV78/TRV78E/TRV88/TRV98/TRV98E

Switch setting:

NIGHT SHOT (Lens block) OFF

Preparations:

- 1) The minipattern box is installed as shown in the following figure.
Note: The attachment lenses are not used.
- 2) Install the minipattern box so that the distance between it and the front of the lens of the camcorder is less than 3cm.
- 3) Make the height of the minipattern box and the camcorder equal.
- 4) Check that the output voltage of the regulated power supply is the specified voltage.
- 5) Check that at both the zoom lens TELE end and WIDE end, the center of the Siemens star chart and center of the exposure screen coincide.

Specified voltage:

The specified voltage varies according to the minipattern box, so adjust the power supply output voltage to the specified voltage written on the sheet which is supplied with the minipattern box.

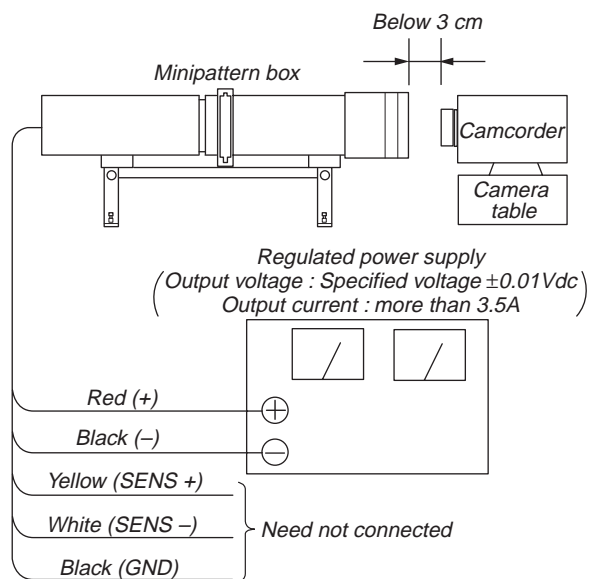

Fig. 5-1-8.

Adjusting method:

Order	Page	Address	Data	Procedure
1	0	01	01	Set the data.
2	F	A0		Only for 1/4 CCD model, write down the data.
3	F	A0	00	Only for 1/4 CCD model, set the data and press PAUSE button.
4	6	01	13	Set the data, and press PAUSE button.
5	6	01	27	Set the data, and press PAUSE button.
6	6	02		Check that the data changes to "01". (Note4)
7	F	A0		Only for 1/4 CCD model, set the data that is written down at step 2 and press PAUSE button.

Note4: The adjustment data will be automatically input to page: F, address: 4E to 5D, 61.

Processing after Completing Adjustments:

Order	Page	Address	Data	Procedure
1	6	01	00	Set the data, and press PAUSE button.
2	0	01	00	Set the data.
3				Turn off the power and turn on again.
4				Perform "Flange Back Check".

4. Flange Back Adjustment (Using Flange Back Adjustment Chart and Subject More Than 500m Away)

The inner focus lens flange back adjustment is carried out automatically. In whichever case, the focus will be deviated during auto focusing/manual focusing.

4-1. Flange Back Adjustment (1)

Subject	Flange back adjustment chart (2.0 m from the front of the protection glass) (Luminance: 350 ± 30 lux)
Measuring Instrument	Adjustment remote commander
Adjustment Page	F
Adjustment Address	4E to 5D, 61

Note1: Check that the data of page: 6, address: 02 is "00". If not, to page: 6, address: 01, set data: 00, and press the PAUSE button.

Note2: 1/4 CCD model: CCD-TR818/TRV68/TRV78/TRV78E/TRV88/TRV98/TRV98E

Switch setting:

NIGHT SHOT (Lens block) OFF

Adjusting method:

Order	Page	Address	Data	Procedure
1	0	01	01	Set the data.
2	F	A0		Only for 1/4 CCD model, write down the data.
3	F	A0	00	Only for 1/4 CCD model, set the data and press PAUSE button.
4	6	01	13	Set the data, and press PAUSE button.
5	6	01	15	Set the data, and press PAUSE button.
6	6	02		Check that the data changes to "01". (Note3)
7	F	A0		Only for 1/4 CCD model, set the data that is written down at step 2 and press PAUSE button.

Note3: The adjustment data will be automatically input to page: F, address: 4E to 5D, 61.

Processing after Completing Adjustments:

Order	Page	Address	Data	Procedure
1	6	01	00	Set the data, and press PAUSE button.
2				Turn off the power and turn on again.
3				Perform "Flange Back Adjustment (2)"

4-2. Flange Back Adjustment (2)

Perform this adjustment after performing "Flange Back Adjustment (1)".

Subject	Subject more than 500m away (Subjects with clear contrast such as buildings, etc.)
Measurement Point	Check operation on TV monitor
Measuring Instrument	
Adjustment Page	F
Adjustment Address	4E to 5D, 61

Note1: Check that the data of page: 6, address: 02 is "00". If not, to page: 6, address: 01, set data: 00, and press the PAUSE button.

Switch setting:

NIGHT SHOT (Lens block) OFF

Preparations:

- 1) Set the zoom lens to the TELE end and expose a subject that is more than 500m away (subject with clear contrast such as building, etc.). (Nearby subjects less than 500m away should not be in the screen.)

Adjusting method:

Order	Page	Address	Data	Procedure
1	0	01	01	Set the data.
2	F	A0		Only for 1/4 CCD model, write down the data.
3	F	A0	00	Only for 1/4 CCD model, set the data and press PAUSE button.
4	6	01	13	Set the data, and press PAUSE button.
5				Place a ND filter on the lens so that the optimum image is obtain.
6	6	01	29	Set the data, and press PAUSE button.
7	6	02		Check that the data changes to "01". (Note2)
8	F	A0		Only for 1/4 CCD model, set the data that is written down at step 2 and press PAUSE button.

Note2: The adjustment data will be automatically input to page: F, address: 4E to 5D, 61.

Processing after Completing Adjustments:

Order	Page	Address	Data	Procedure
1	6	01	00	Set the data, and press PAUSE button.
2	0	01	00	Set the data.
3				Turn off the power and turn on again.
4				Perform "Flange Back Check".

5. Flange Back Check

Subject	Siemens star (2.0m from the front of the lens) (Luminance : approx. 200 lux)
Measurement Point	Check operation on TV monitor
Measuring Instrument	
Specified Value	Focused at the TELE end and WIDE end.

Note: When the auto focus is ON, the lens can be checked if it is focused or not by observing the data on the page 1 of the adjustment remote commander.

- 1) Select page: 0, address: 03, and set data: 0F.
- 2) Page 1 shows the state of the focus.

1 : 00 : XX
 Odd: Focused
 Even: Unfocused

Switch setting:

NIGHT SHOT (Lens block)OFF

Checking method:

- 1) Select page: 6, address: 40, and set data: 02.
- 2) Select page: 6, address: 41, and set data: 01.
- 3) Place the Siemens star 2.0m from the front of the lens.
- 4) To open the IRIS, decrease the luminous intensity to the Siemens star up to a point before noise appear on the image.
- 5) Shoot the Siemens star with the zoom TELE end.
- 6) Turn on the auto focus.
- 7) Check that the lens is focused (Note).
- 8) Select page: 6, address: 21, and set data: 10.
- 9) Shoot the Siemens star with the zoom WIDE end.
- 10) Observe the TV monitor and check that the lens is focused.

Processing after Completing Adjustments:

- 1) Select page: 6, address: 21, and set data: 00.
- 2) Select page: 6, address: 40, and set data: 00.
- 3) Select page: 6, address: 41, and set data: 00.
- 4) Select page: 0, address: 03, and set data: 00.

6. Picture Frame Setting

Subject	Color bar chart (Color reproduction adjustment frame) (1.5m from the front of the lens)
Measurement Point	Video output terminal
Measuring Instrument	Oscilloscope and TV monitor
Specified Value	A=B, C=D, E=F

Switch setting:

- 1) NIGHT SHOT (Lens block) OFF
- 2) DIGITAL ZOOM (Menu display) OFF
- 3) STEADY SHOT (Menu display) OFF
- 4) LIGHT (FK-1000 block) OFF

Setting method:

- 1) Adjust the zoom and the camera direction, and set to the specified position.
- 2) Mark the position of the picture frame on the monitor display, and adjust the picture frame to this position in following adjustments using "Color reproduction adjustment frame".

Check on the oscilloscope

1. Horizontal period

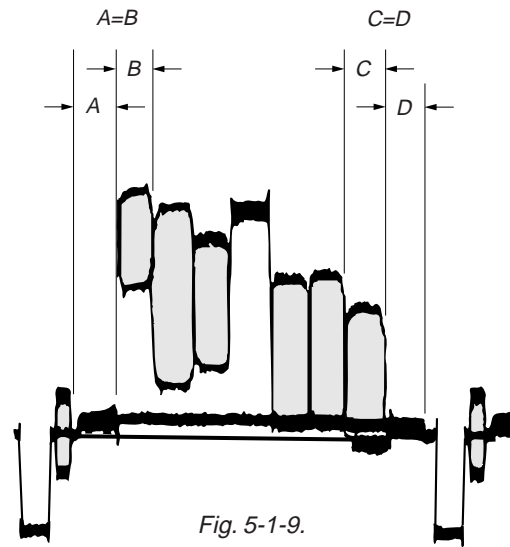

2. Vertical period

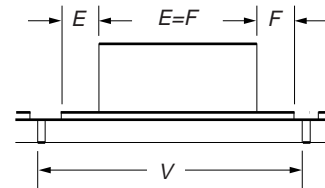

Check on the monitor TV (Underscanned mode)

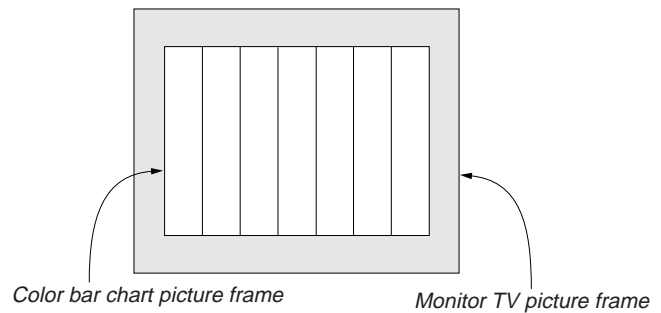

7. Color Reproduction Adjustment

Adjust the color Separation matrix coefficient so that proper color reproduction is produced.

Subject	Color bar chart (Color reproduction adjustment frame)
Measurement Point	Video output terminal
Measuring Instrument	Vectorscope
Adjustment Page	F
Adjustment Address	47, 49, D7, D8
Specified Value	All color luminance points should settle within each color reproduction frame.

Note: NTSC model: CCD-TR618/TR818/TRV49/TRV58/TRV68/
TRV78/TRV88/TRV98
PAL model: CCD-TR618E/TR718E/TR728E/TRV49E/TRV58E/
TRV59E/TRV78E/TRV98E

Switch setting:

- 1) NIGHT SHOT (Lens block) OFF
- 2) DIGITAL ZOOM (Menu display) OFF
- 3) STEADY SHOT (Menu display) OFF
- 4) LIGHT (FK-1000 block) OFF

Adjusting method:

- 1) Select page: 0, address: 01, and set data: 01.
- 2) Select page: F, address: 8B, and write down the data.
- 3) Select page: F, address: 8B, set data: 29 and press the PAUSE button.
- 4) Select page: F, address: 2B, set the following data and press the PAUSE button.
17: NTSC model
97: PAL model
- 5) Select page: 6, address: 01, set data: 3D, and press the PAUSE button.
- 6) Adjust the GAIN and PHASE of the vectorscope, and adjust the burst luminance point to the burst position of the color reproduction frame.
- 7) Change the data of page: F, address: 47, 49, D7 and D8, settle each color luminance point in each color reproduction frame.

Note: Be sure to press the PAUSE button of the adjustment remote commander before changing the addresses. If not, the new data will not be written to the memory.

Processing after Completing Adjustments:

- 1) Select page: F, address: 8B, set the data written down at step 2), and press the PAUSE button.
- 2) Select page: 6, address: 01, set data: 00, and press the PAUSE button.
- 3) Select page: 0, address: 01, and set data: 00.

For NTSC model

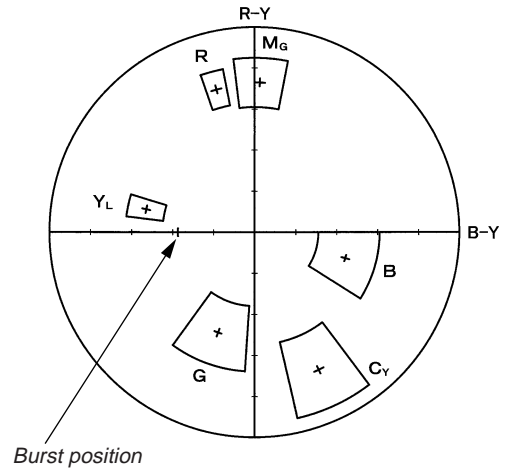

For PAL model

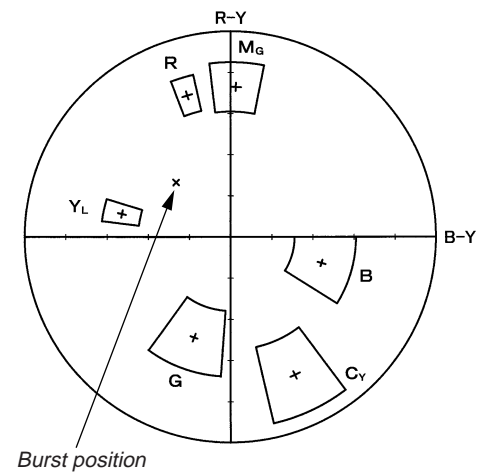

Fig. 5-1-12.

8. Auto White Balance & LV Standard Data Input

Adjust the white balance reference at 3200K, and adjust the normal coefficient of the light value.

Subject	Clear chart (Color reproduction adjustment frame)
Measurement Point	Display data of page 1 (Note3)
Measuring Instrument	Adjustment remote commander
Adjustment Page	F
Adjustment Address	3C to 41

Note1: This adjustment should be carried out upon completion of "Color reproduction adjustments".

Note2: After the power is turned on, this adjustment can be done only once.

Note3: Check that the data of page: 6, address: 02 is "00". If not, to page: 6, address: 01, set data: 00, and press the PAUSE button.

Switch setting:

- 1) NIGHT SHOT (Lens block) OFF
- 2) DIGITAL ZOOM (Menu display) OFF
- 3) STEADY SHOT (Menu display) OFF
- 4) LIGHT (FK-1000 block) OFF

Adjusting method:

Order	Page	Address	Data	Procedure
1	0	01	01	Set the data.
2				Wait for 2 sec.
3	6	01	11	Set the data, and press PAUSE button.
4	6	01	0D	Set the data, and press PAUSE button
5	6	02		Check that the data changes to "01". (Note4)

Note4: The adjustment data will be automatically input to page: E, address: 3C to 41.

Processing after Completing Adjustments

Order	Page	Address	Data	Procedure
1	6	01	00	Set the data, and press PAUSE button.
2	0	01	00	Set the data.
3				Perform "Auto White Balance Adjustment".

9. Auto White Balance Adjustment

Adjust to the proper auto white balance output data.
If it is not correct, auto white balance and color reproducibility will be poor.

Subject	Clear chart (Color reproduction adjustment frame)
Filter	Filter C14 for color temperature correction
Measurement Point	Display data of page 1 (Note4)
Measuring Instrument	Adjustment remote commander
Adjustment Page	F
Adjustment Address	42, 43
Specified Value	1/6 CCD NTSC model: R ratio: 2AC0 to 2B40 B ratio: 5E20 to 5EE0 1/6 CCD PAL model: R ratio: 2B40 to 2BC0 B ratio: 61A0 to 6260 1/4 CCD NTSC model: R ratio: 2D40 to 2DC0 B ratio: 5D20 to 5DE0 1/4 CCD PAL model: R ratio: 2B40 to 2BC0 B ratio: 5D20 to 5DE0

Note1: 1/6 CCD NTSC model: CCD-TR618/TRV49/TRV58
1/6 CCD PAL model: CCD-TR618E/TR718E/TR728E/TRV49E/TRV58E/TRV59E

1/4 CCD NTSC model: CCD-TR818/TRV68/TRV78/TRV88/TRV98
1/4 CCD PAL model: CCD-TRV78E/TRV98E

Note2: After the power is turned on, this adjustment can be done only once.

Note3: Perform "Auto White Balance & LV Standard Data Input" before this adjustment.

Note4: Displayed data of page 1 of the adjustment remote commander.

1 : XX : XX
 Display data

Switch setting:

- 1) NIGHT SHOT (Lens block)OFF
- 2) DIGITAL ZOOM (Menu display)OFF
- 3) STEADY SHOT (Menu display)OFF
- 4) LIGHT (FK-1000 block)OFF

Adjusting method:

Order	Page	Address	Data	Procedure
1				Place the C14 filter for color temperature correction on the lens.
2	0	01	01	Set the data.
3	F	B8		Write down the data.
4	F	B8		Set the following data, and press PAUSE button. 2B: 1/6 CCD NTSC model 2B: 1/6 CCD PAL model 2D: 1/4 CCD NTSC model 2B: 1/4 CCD PAL model
5	F	B9		Write down the data.
6	F	B9		Set the following data, and press PAUSE button. 00: 1/6 CCD NTSC model 80: 1/6 CCD PAL model 80: 1/4 CCD NTSC model 80: 1/4 CCD PAL model
7	F	BA		Write down the data.
8	F	BA		Set the following data, and press PAUSE button. 5E: 1/6 CCD NTSC model 62: 1/6 CCD PAL model 5D: 1/4 CCD NTSC model 5D: 1/4 CCD PAL model
9	F	BB		Write down the data.
10	F	BB		Set the following data, and press PAUSE button. 80: 1/6 CCD NTSC model 00: 1/6 CCD PAL model 80: 1/4 CCD NTSC model 80: 1/4 CCD PAL model
11	6	01	A7	Set the data, and press PAUSE button.
12				Wait for 2 sec.
13	6	01	A5	Set the data, and press PAUSE button.
14	6	02		Check that the data changes to "01". (Note5)
15	6	01	3F	Set the data, and press PAUSE button.
16	0	03	04	Set the data.
17	1			Check that the display data (Note4) satisfies the R ratio specified value.
18	0	03	05	Set the data.
19	1			Check that the display data (Note4) satisfies the B ratio specified value.

Note5: The adjustment data will be automatically input to page: F, address: 42,43.

Processing after Completing Adjustments:

Order	Page	Address	Data	Procedure
1	6	01	00	Set the data, and press PAUSE button.
2	F	B8		Set the data that is written down at step 3, and press PAUSE button.
3	F	B9		Set the data that is written down at step 3, and press PAUSE button.
4	F	BA		Set the data that is written down at step 3, and press PAUSE button.
5	F	BB		Set the data that is written down at step 3, and press PAUSE button.
6	0	03	00	Set the data.
7	0	01	00	Set the data.

11. Angular Velocity Sensor Sensitivity Adjustment (CCD-TR818/TRV68/TRV78/TRV78E/TRV88/TRV98/ TRV98E)

Precautions on the Parts Replacement

There are two types of repair parts.

Type A: ENC03JA

Type B: ENC03JB

Replace the broken sensor with a same type sensor. If replace with other type parts, the image will vibrate up and down or left and right during hand-shake correction operations. After replacing, re-adjust according to the adjusting method after replacement.

Precautions on Angular Velocity Sensor

The sensor incorporates a precision oscillator. Handle it with care as if it dropped, the balance of the oscillator will be disrupted and operations will not be performed properly.

Subject	Arbitrary
Measurement Point	Display data of page 1 (Note1)
Measuring Instrument	Adjustment remote commander
Adjustment Page	F
Adjustment Address	5E, 5F
Specified Value	2700 to 5100

Note1: Displayed data of the adjustment remote commander.

1 : XX : XX

└───┬───┘ Display data

Note2: MI-040 board: CCD-TR818

MI-041 board: CCD-TRV68/TRV78/TRV78E/TRV88/TRV98/
TRV98E

Switch setting:

- 1) STEADY SHOT (Menu display) ON
- 2) ZOOM Center

Adjusting method:

Order	Page	Address	Data	Procedure
1	0	01	01	Set the data.
2	F	5E		Set the following data, and press PAUSE button. 5A (NTSC), 74 (PAL)
3	F	5F		Set the following data, and press PAUSE button. 57 (NTSC), 5D (PAL)
				Pitch sensor check (MI-040/041 board SE751)
4	0	03	11	Set the data.
5	1			Check that the display data (Note1) satisfies the specified value.
				Yaw sensor check (MI-040/041 board SE752)
6	0	03	12	Set the data.
7	1			Check that the display data (Note1) satisfies the specified value.

Processing after Completing Adjustments

Order	Page	Address	Data	Procedure
1	0	01	00	Set the data.
2	0	03	00	Set the data.
3				Move the camcorder, and check that the steady shot operations have been performed normally

1-4. COLOR ELECTRONIC VIEWFINDER SYSTEM ADJUSTMENT (CCD-TR818)

Note1: The back light (fluorescent tube) is driven by a high voltage AC power supply. Therefore, do not touch the back light holder to avoid electrical shock.

Note2: When replacing the LCD unit, be careful to prevent damages caused by static electricity.

[Adjusting connector]

Most of the measuring points for adjusting the viewfinder system are concentrated in CN713 of VC-251 board or CPC connector of FP-262 flexible.

Connect the Measuring instruments and the adjustment remote commander via the CPC jig for BX/BK (J-6082-521-A) to CN713 or CPC connector. To operate the adjustment remote commander, connect the AC power adapter to the DC IN jack of CPC jig for BX/BK, or connect the L series Info-LITHIUM battery to the battery terminal of CPC jig for BX/BK.

The following table shows the Pin No. and signal name of CN713 or CPC connector.

Pin No.	Signal Name	Pin No.	Signal Name
1	VCO	2	XLANC POWER ON
3	EVF BL	4	LANC IN
5	EVF BL 4.75V	6	LANC OUT
7	EVF VG	8	CAP FG
9	PB RF	10	REG GND
11	REG GND	12	REG GND
13	BPF MONI	14	IR VIDEO
15	REC RF	16	RF SWP
17	NC	18	NC
19	NC	20	NC

Table. 5-1-6.

The following table shows the arrangement of the test points of CPC jig for BX/BK. (Pin No. are those of CN713 or CPC connector.)

Pin No.	Signal Name	Pin No.	Signal Name
3	BL	1	EVF VCO
7	EVF VG	5	BL 4.75
9	PB RF (MON)		
13	BPF MONI	10	GND
17	TMS	15	REC RF (RF IN)
20	TDI	19	TDO
16	SWP	18	TCK
15	CAP FG	14	IR VIDEO

Table. 5-1-7.

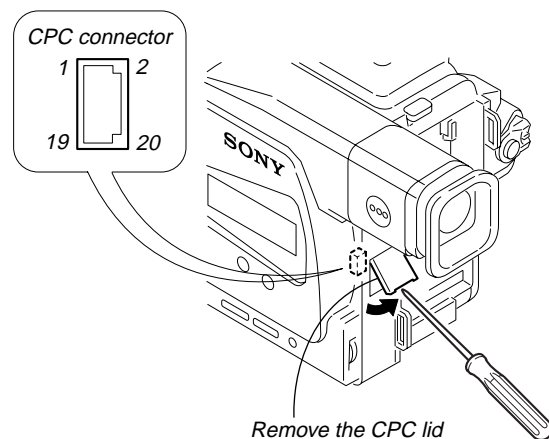

Fig. 5-1-14.

1. RGB AMP Adjustment (VF-141 board)

Set the D range of the RGB driver used to drive the LCD to the specified value. If deviated, the LCD screen will become blackish or saturated (whitish).

Mode	Camera
Subject	Arbitrary
Measurement Point	EVF VG (Pin ⑦ of CPC connector of FP-262 flexible or Pin ⑦ of CN713 of VC-251 board)
Measuring Instrument	Oscilloscope
Adjustment Page	7
Adjustment Address	D8
Specified Value	$A = 7.20 \pm 0.10V$

Adjusting method:

Order	Page	Address	Data	Procedure
1	0	01	01	Set the data.
2	7	D8		Change the data and set the voltage (A) between the reversed waveform pedestal and non-reversed waveform pedestal to the specified value.
3	7	D8		Press PAUSE button.
4	0	01	00	Set the data.

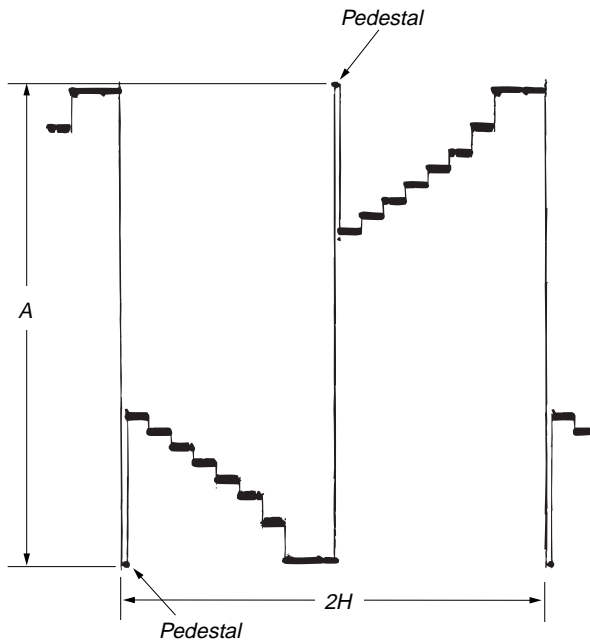

Fig. 5-1-15.

2. Contrast Adjustment (VF-141 board)

Set the level of the VIDEO signal for driving the LCD to the specified value. If deviated, the screen image will be blackish or saturated (whitish).

Mode	Camera
Subject	Arbitrary
Measurement Point	EVF VG (Pin ⑦ of CPC connector of FP-262 flexible or Pin ⑦ of CN713 of VC-251 board)
Measuring Instrument	Oscilloscope
Adjustment Page	7
Adjustment Address	DC
Specified Value	$A=2.20 \pm 0.10V$

Adjusting method:

Order	Page	Address	Data	Procedure
1	0	01	01	Set the data.
2	7	DC		Change the data and set the voltage (A) between the 100 IRE and 0 IRE (pedestal) to the specified value. (The data should be "00" to "7F".)
3	7	DC		Press PAUSE button.
4	0	01	00	Set the data.

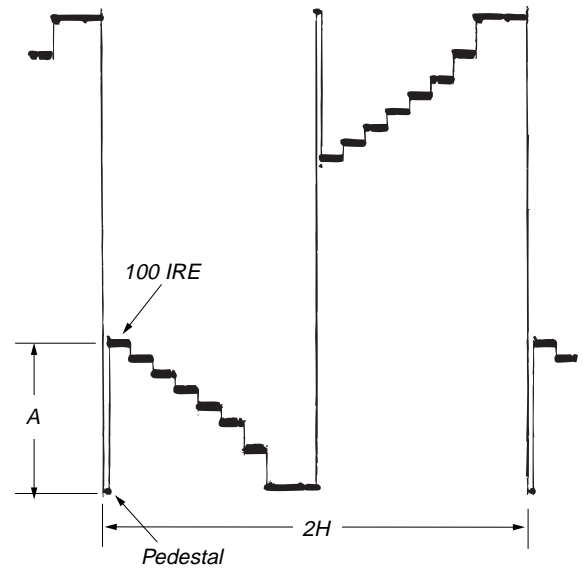

Fig. 5-1-16.

3. Backlight Consumption Current Adjustment (LB-062 board)

Set the backlight luminance and color temperature. If deviated, the image may become dark or bright.

Mode	Camera
Subject	Arbitrary
Measurement Point	+ Probe: BL 4.75V (Pin ⑤ of CPC connector of FP-262 flexible or Pin ⑤ of CN713 of VC-251 board) – Probe: BL (Pin ③ of CPC connector of FP-262 flexible or Pin ③ of CN713 of VC-251 board)
Measuring Instrument	Digital voltmeter
Adjustment Page	7
Adjustment Address	DF, E0, E1
Specified Value	BRIGHT mode : A=15.5 ± 1mVdc NORMAL mode : A=9.5 ± 1mVdc

Note1: Perform the adjustment in the following order.

Adjusting method:

Order	Page	Address	Data	Procedure
1	0	01	01	Set the data.
2	7	DF	CA	Set the data, and press PAUSE button.
3	7	E0	07	Set the data, and press PAUSE button.
4	7	E1	91	Set the data, and press PAUSE button.
5	7	E0		Change the data and set the voltage difference (A) between BL4.75V and BL to the specified value of BRIGHT mode. (The data should be “00” to “3F”.)
6	7	E0		Press PAUSE button.
7	7	E0		Read the data, and this data is named DE0.
8				Convert DE0 to decimal notation, and obtain DE0'. (Note2)
9				Calculate DDF' using following equations (Decimal calculation) $DDF' = DE0' + 192$
10				Convert DDF' to a hexadecimal number, and obtain DDF. (Note2) (The data should be “C0” to “FF”.)
11	7	DF	DDF	Set the data, and press PAUSE button.
12	7	E1		Change the data and set the voltage difference (A) between BL4.75V and BL to the specified value of NORMAL mode. (The data should be “80” to “9F”.)
13	7	E1		Press PAUSE button.
14	0	01	00	Set the data.

Note2: Refer to “Table 5-4-1. Hexadecimal-decimal Conversion Table”.

4. White Balance Adjustment (VF-141 board)

Correct the white balance.

If deviated, the reproduction of the EVF screen may degenerate.

Mode	Camera
Signal	Arbitrary
Measurement Point	Check on EVF screen
Measuring Instrument	
Adjustment Page	7
Adjustment Address	DA, DB
Specified Value	The EVF screen should not be colored.

Note1: Check the white balance only when replacing the following parts. If necessary, adjust them.
1. LCD panel
2. Light induction plate
3. IC4501

Adjusting method:

Order	Page	Address	Data	Procedure
1	0	01	01	Set the data.
2	7	DA	8D	Set the data, and press PAUSE button.
3	7	DB	83	Set the data, and press PAUSE button.
4	7	DA		Check that the EVF screen is not colored. If not colored, proceed to step 10.
5	7	DA		Change the data so that the EVF screen is not colored.
6	7	DA		Press PAUSE button.
7	7	DB		Change the data so that the EVF screen is not colored.
8	7	DB		Press PAUSE button.
9	7	DB		If the EVF screen is colored, repeat steps 5 to 9.
10	0	01	00	Set the data.

1-5. MONOCHROME ELECTRONIC VIEWFINDER SYSTEM ADJUSTMENT (CCD-TR618/TR618E/TR718E/TR728E/TRV49/TRV49E/TRV58/TRV58E/TRV59E/TRV68/TRV78/TRV78E/TRV88/TRV98/TRV98E)

1-5-1. Horizontal Slant Check

Mode	Playback
Signal	Alignment tape : For checking operation (WR5-5NSP (NTSC)) (WR5-5CSP (PAL)) Monoscope section
Specified Value	$\pm 1.5^\circ$

Adjusting method:

- 1) Adjust RV904 (BRIGHT) (VF-129 board) so that the CRT can be seen easily and clearly.
- 2) Check that the difference between the horizontal line and the tilt of black mask satisfies the specified value.

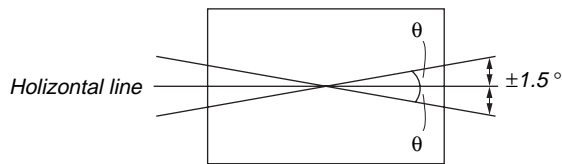

Specified value : The image should be within $\pm 1.5^\circ$ of the horizontal line.

Fig. 5-1-17.

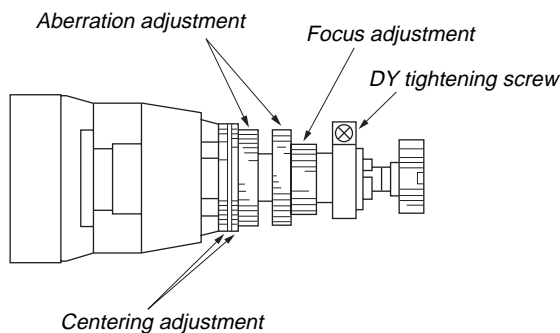
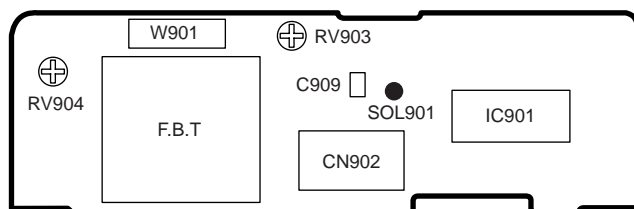

Fig. 5-1-18.

VF-129 BOARD



1-5-2. Centering Adjustment

Mode	Playback
Signal	Alignment tape : For checking operation (WR5-5NSP (NTSC)) (WR5-5CSP (PAL)) Monoscope section
Specified Value	$\pm 4\%$

Adjusting method:

- 1) Use the centering adjustment ring and adjust so that the left, light, top, and bottom sides of the display are uniform. (Refer to Fig. 5-1-18.)

Note: As the centering position changes due to earth magnetism, rotate it 360° in the horizontal direction, and adjust with the center section of the modifying position.

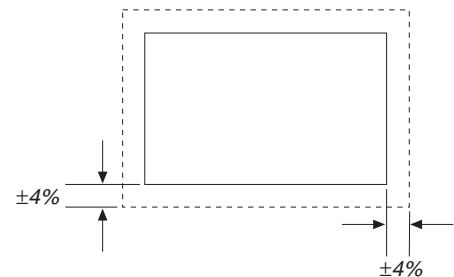

Adjustment value : $\pm 4\%$

Fig. 5-1-19.

1-5-3. Focus Adjustment

Mode	Playback
Signal	Alignment tape : For checking operation (WR5-5NSP (NTSC)) (WR5-5CSP (PAL)) Monoscope section

Adjusting method:

- 1) Adjust the focus ring to obtain the optimum focus. (Refer to Fig. 5-1-18.)

1-5-4. Aberration Adjustment

Mode	VTR stop
Signal	Dot pattern
Specified Value	$b1 \leq 2 \times a1$ $b2 \leq 0.8 \times a2$

Adjusting method:

- 1) Adjust the aberration adjustment ring so that the tracing of the dot satisfies the specified value.
- 2) If the centering becomes displaced here, perform the centering adjustment from the beginning again.

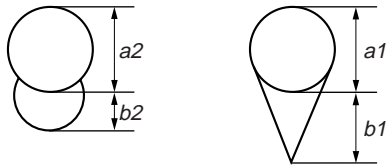

Fig. 5-1-20.

1-5-5. Horizontal Amplitude Adjustment (VF-129 board)

Mode	Playback
Signal	Alignment tape : For checking operation (WR5-5NSP (NTSC)) (WR5-5CSP (PAL)) Monoscope section
Adjusting Element	C909 (SOL901)
Specified Value	$12 \pm 6\%$

Adjusting method:

- 1) Rotate RV903, and adjust the top and bottom side of the monoscope image to the top and bottom edges of the display.
- 2) Rotate RV904 so that the brightness is the normal level.
- 3) Solder or unsolder SOL901 pattern of the H size adjustment capacitor (C909) to "short" or "open", so that the horizontal direction over scan becomes $10 \pm 6\%$ (Left and right totals).

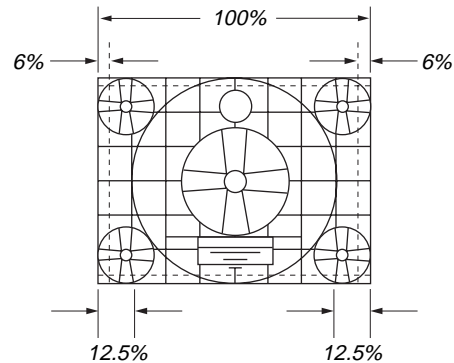

SOL901	Size H
Open	Small
Short	Big

Fig. 5-1-21.

VF-129 BOARD

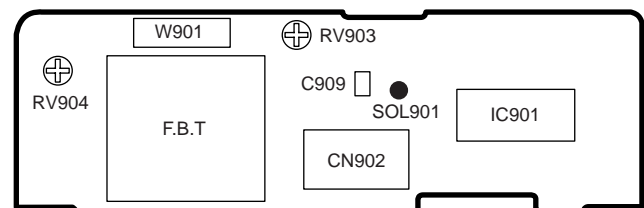

1-5-6. Vertical Amplitude Adjustment (VF-129 board)

Mode	Playback
Signal	Alignment tape : For checking operation (WR5-5NSP (NTSC)) (WR5-5CSP (PAL)) Monoscope section
Adjusting Element	RV903
Specified Value	$10 \pm 3\%$

Adjusting method:

- 1) Adjust RV903 so that the vertical direction over scan becomes $10 \pm 3\%$ (Top and bottom totals).

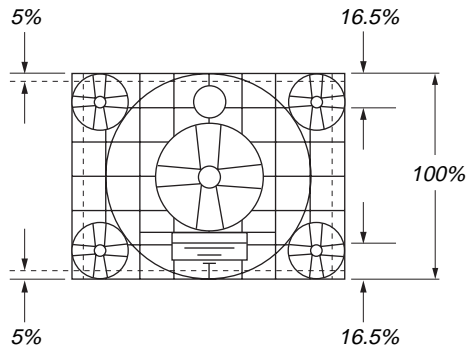

Fig. 5-1-22.

1-5-7. Brightness Adjustment (VF-129 board)

Mode	Playback
Signal	Alignment tape : For checking operation (WR5-5NSP (NTSC)) (WR5-5CSP (PAL)) Monoscope section
Adjusting Element	RV904

Adjusting method:

- 1) Rotate RV904, and adjust so that the bright/dark sections of gray scale are displayed correctly. (The bright section should be unsatisfactory till the cross hatch appears vague in the monoscope circle. The dark section should be unsatisfactory till the darkest section of the gray scale cannot be differentiate.)

1-5-8. Horizontal Amplitude, Vertical Amplitude, Focus Check

“1-5-5. Horizontal Amplitude Adjustment” and “1-5-6. Vertical Amplitude Adjustment” should be both satisfy the specified values. If not, perform the adjustments from the beginning again. In this case, perform “1-5-7. Brightness Adjustment” again. Moreover, check the focus, and if it found to be vague, perform “1-5-3. Focus Adjustment” and “1-5-4. Aberration Adjustment”.

1-6. LCD SYSTEM ADJUSTMENT (CCD-TRV49/TRV49E/TRV58/TRV58E/TRV59E/ TRV68/TRV78/TRV78E/TRV88/TRV98/TRV98E)

Note 1: The back light (fluorescent tube) is driven by a high voltage AC power supply. Therefore, do not touch the back light holder to avoid electrical shock.

Note 2: When replacing the LCD unit, be careful to prevent damages caused by static electricity.

Note 3: Set the LCD BRIGHT (Menu display) to the center.
Set the LCD COLOR (Menu display) to the center.

Note 4: Connect the adjustment remote commander to CN713 of VC-251 board or CPC connector of FP-262 flexible via CPC jig for BX/BK (J-6082-521-A). To operate the adjustment remote commander, connect the AC power adapter (8.4Vdc) to the DC IN jack of CPC jig for BX/BK, or connect the L series Info-LITHIUM battery to the battery terminal of CPC jig for BX/BK.

[Adjusting connector]

Most of the measuring points for adjusting the LCD system are concentrated in CN5502 of the PD-131 board. Connect the measuring instruments via the multi CPC jig (J-6082-311-A). The following table shows the Pin No. and signal name of CN5502.

Pin No.	Signal Name	Pin No.	Signal Name
1	VB	2	XVD OUT
3	VG	4	PANEL COM/PSIG
5	VR	6	PANEL ID
7	C-SYNC/XHD	8	XHD OUT
9	GND	10	GND

Table. 5-1-8.

1. LCD Type Check

By measuring the resistor value between Pin ⑥ of CN5502 and GND, the type of LCD can be discriminated.

Resistor value	LCD type	CCD-
1.0kΩ	2.5 LCD TYPE S (61k)	TRV49,TRV49E,TRV58, TRV58E,TRV59E, TRV68,TRV78,TRV78E
4.7kΩ	3.0 LCD TYPE S (123k)	TRV88
5.6kΩ	3.5 LCD TYPE S (123k)	TRV98,TRV98E

Table. 5-1-9.

PD-131 board

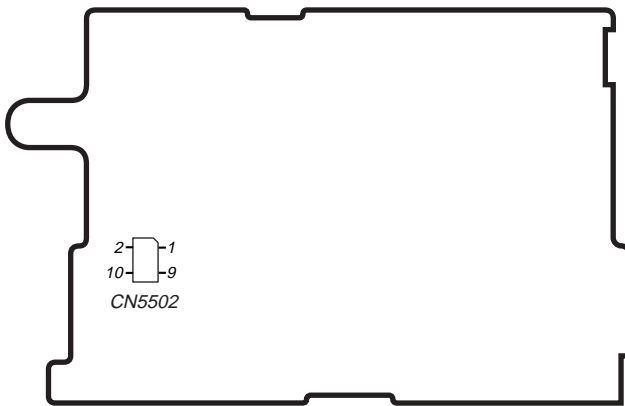

2. VCO Adjustment (PD-131 board)

Set the VCO free-run frequency. If deviated, the LCD screen will be blurred.

Mode	VTR stop
Signal	No signal
Measurement Point	Pin ⑧ of CN5502 (XHD OUT)
Measuring Instrument	Frequency counter
Adjustment Page	7
Adjustment Address	E5, E6
Specified Value	$f = 15734 \pm 30\text{Hz}$ (NTSC) $f = 15625 \pm 30\text{Hz}$ (PAL)

Note1: NTSC model: CCD-TRV49/TRV58/TRV68/TRV78/TRV88/TRV98

PAL model: CCD-TRV49E/TRV58E/TRV59E/TRV78E/TRV98E

Note2: Refer to “1. LCD Type Check” for the discrimination of the LCD type.

Adjusting method:

Order	Page	Address	Data	Procedure
1	0	01	01	Set the data.
2	7	E5		Change the data and set the VCO frequency (f) to the specified value.
3	7	E5		Press PAUSE button.
4	7	E5		Read the data, and this data is named DE_5 .
5				Convert DE_5 to decimal notation, and obtain DE_5' . (Note3)
6				Calculate DE_6' using following equations (Decimal calculation) [2.5 LCD TYPE S] When $DE_5' \geq 20$ $DE_6' = DE_5' - 20$ When $DE_5' < 20$ $DE_6' = 00$ [3.0 LCD TYPE S] When $DE_5' \geq 23$ $DE_6' = DE_5' - 23$ When $DE_5' < 23$ $DE_6' = 00$ [3.5 LCD TYPE S] When $DE_5' \geq 4$ $DE_6' = DE_5' - 4$ When $DE_5' < 4$ $DE_6' = 00$
7				Convert DE_6' to a hexadecimal number, and obtain DE_6 . (Note3)
8	7	E6	DE_6	Set the data, and press PAUSE button.
9	0	01	00	Set the data.

Note3: Refer to “Table 5-4-1. Hexadecimal-decimal Conversion Table”.

3. RGB AMP Adjustment (PD-131 board)

Set the D range of the RGB decoder used to drive the LCD to the specified value. If deviated, the LCD screen will become blackish or saturated (whitish).

Mode	VTR stop
Signal	No signal
Measurement Point	Pin ③ of CN5502 (VG) External trigger: Pin ④ of CN5502 (PANEL COM)
Measuring Instrument	Oscilloscope
Adjustment Page	7
Adjustment Address	E8
Specified Value	$A = 3.60 \pm 0.05\text{V}$

Note: Refer to “1. LCD Type Check” for the discrimination of the LCD type.

Adjusting method:

Order	Page	Address	Data	Procedure
1	0	01	01	Set the data.
2	7	E8		Change the data and set the voltage (A) between the reversed waveform pedestal and non-reversed waveform pedestal to the specified value. (The data should be “00” to “3F”.)
3	7	E8		Press PAUSE button.
4	0	01	00	Set the data.

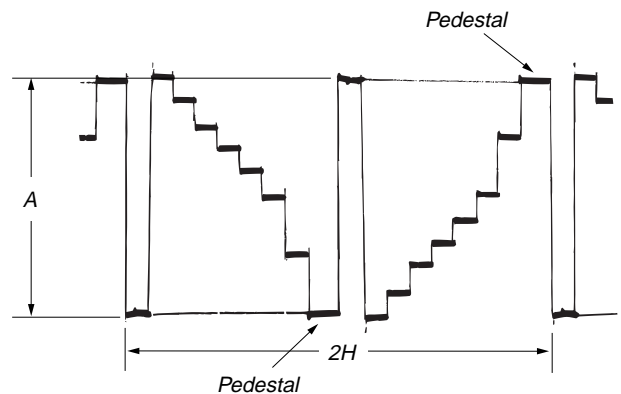

Fig. 5-1-23.

4. Contrast Adjustment (PD-131 board)

Set the level of the VIDEO signal for driving the LCD to the specified value. If deviated, the screen image will be blackish or saturated (whitish).

Mode	VTR stop
Signal	No signal
Measurement Point	Pin ③ of CN5502 (VG) External trigger: Pin ④ of CN5502 (PANEL COM)
Measuring Instrument	Oscilloscope
Adjustment Page	7
Adjustment Address	ED
Specified Value	2.5 LCD TYPE S: A = 3.55 ± 0.07V 3.0/3.5 LCD TYPE S: A = 3.35 ± 0.07V

Note: Refer to "1. LCD Type Check" for the discrimination of the LCD type.

Adjusting method:

Order	Page	Address	Data	Procedure
1	0	01	01	Set the data.
2	7	ED		Change the data and set the voltage (A) between the 100 IRE and 0 IRE (pedestal) to the specified value. (The data should be "00" to "7F".)
3	7	ED		Press PAUSE button.
4	0	01	00	Set the data.

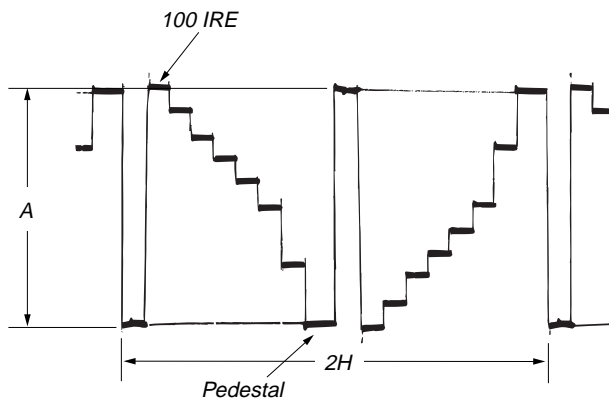

Fig. 5-1-24.

5. COM AMP Adjustment (PD-131 board)

Set the common electrode drive signal level of LCD to the specified value.

Mode	VTR stop
Signal	No signal
Measurement Point	Pin ④ of CN5502 (PANEL COM)
Measuring Instrument	Oscilloscope
Adjustment Page	7
Adjustment Address	EA
Specified Value	2.5 LCD TYPE S: A = 6.30 ± 0.05V (NTSC) A = 6.10 ± 0.05V (PAL) 3.0 LCD TYPE S: A = 6.00 ± 0.05V (NTSC) 3.5 LCD TYPE S: A = 5.90 ± 0.05V (NTSC) A = 6.00 ± 0.05V (PAL)

Note1: Refer to "1. LCD Type Check" for the discrimination of the LCD type.

Note2: NTSC model: CCD-TRV49/TRV58/TRV68/TRV78/TRV88/TRV98
PAL model: CCD-TRV49E/TRV58E/TRV59E/TRV78E/TRV98E

Adjusting method:

Order	Page	Address	Data	Procedure
1	0	01	01	Set the data.
2	7	EA		Change the data and set the PANEL COM signal level (A) to the specified value.
3	7	EA		Press PAUSE button.
4	0	01	00	Set the data.

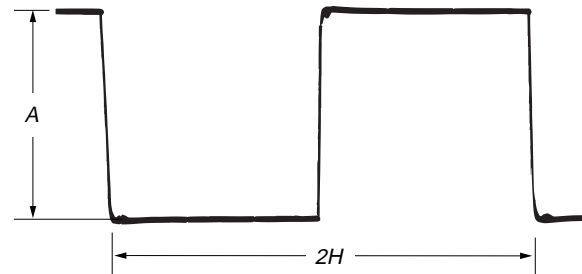

Fig. 5-1-25.

6. V-COM Adjustment (PD-131 board)

Set the DC bias of the common electrode drive signal of LCD to the specified value.

If deviated, the LCD display will move, producing flicker and conspicuous vertical lines.

Mode	VTR stop
Signal	No signal
Measurement Point	Check on LCD display
Measuring Instrument	
Adjustment Page	7
Adjustment Address	E7
Specified Value	The brightness difference between the section A and section B is minimum.

Note: This adjustment should be carried out upon completion of the following adjustments.
 RGB AMP Adjustment
 Contrast Adjustment
 COM AMP Adjustment

Adjusting method:

Order	Page	Address	Data	Procedure
1	0	01	01	Set the data.
2	7	E7		Change the data so that the brightness of the section A and that of the section B is equal.
3	7	E7		Subtract 8 from the data.
4	7	E7		Press PAUSE button.
5	0	01	00	Set the data.

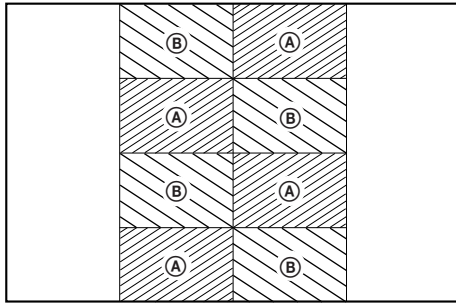

Fig. 5-1-26.

7. White Balance Adjustment (PD-131 board)

Correct the white balance.

If deviated, the reproduction of the LCD screen may degenerate.

Mode	VTR stop
Signal	No signal
Measurement Point	Check on LCD screen
Measuring Instrument	
Adjustment Page	7
Adjustment Address	EB, EC
Specified Value	The LCD screen should not be colored.

Note1: Check the white balance only when replacing the following parts.
 If necessary, adjust them.
 1. LCD panel
 2. Light induction plate
 3. IC5501

Adjusting method:

Order	Page	Address	Data	Procedure
1	0	01	01	Set the data.
2	E	EB	60	Set the data, and press PAUSE button.
3	E	EC	65	Set the data, and press PAUSE button.
4	E	EB		Check that the LCD screen is not colored. If not colored, proceed to step 10.
5	E	EB		Change the data so that the LCD screen is not colored.
6	E	EB		Press PAUSE button.
7	E	EC		Change the data so that the LCD screen is not colored.
8	E	EC		Press PAUSE button.
9	E	EC		If the LCD screen is colored, repeat steps 5 to 9.
10	0	01	00	Set the data.

5-2. MECHANISM SECTION ADJUSTMENT

Mechanism Section adjustments, checks, and replacement of mechanism parts, refer to the separate volume “8mm Video Mechanism Adjustment Manual VII [B Mechanism]”.

2-1. ADJUSTMENT REMOTE COMMANDER

Connect the adjustment remote commander to CN713 of VC-251 board or CPC connector of FP-262 flexible via CPC jig for BX/BK (J-6082-521-A). To operate the adjustment remote commander, connect the AC power adapter (8.4Vdc) to the DC IN jack of CPC jig for BX/BK, or connect the L series Info-LITHIUM battery to the battery terminal of CPC jig for BX/BK.

2-2. OPERATING WITHOUT CASSETTE

- 1) Refer to “Section 2. DISASSEMBLY” and supply the power with the cabinet assembly removed. (So that the mechanical deck can be operated.)
- 2) Connect the adjustment remote commander.
- 3) Turn on the HOLD switch of the adjustment remote commander.
- 4) Close the cassette compartment without loading a cassette and complete loading.
- 5) Select page: 0, address: 01, and set data: 01.
- 6) Select page: F, address: 22, set data: 81, and press the PAUSE button of the adjustment remote commander.
- 7) Select page: D, address: 10, set data: 10, and press the PAUSE button of the adjustment remote commander.
- 8) Disconnect the power supply of the unit.

By carrying out the above procedure, the unit can be operated without loading a cassette.

Be sure to carry out “Processing after Operations” after checking the operations.

Set the data of page: D, address: 10 to the following if the sensor ineffective mode, forced VTR power supply On mode or forced camera power supply ON mode are to be used together.

Forced VTR power ON mode 12
 Forced camera power ON mode 11

[Procedure after checking operations]

- 1) Select page: 0, address: 01, and set data: 01.
- 2) Select page: F, address: 22, set data: 80, and press the PAUSE button of the adjustment remote commander.
- 3) Select page: D, address: 10, set data: 00, and press the PAUSE button of the adjustment remote commander.
- 4) Select page: 0, address: 01, and set data: 00.
- 5) Disconnect the power supply of the unit.

2-3. TAPE PATH ADJUSTMENT

1. Preparations for Adjustment

- 1) Clean the tape path face (tape guide, capstan shaft, pinch roller).
- 2) Connect the adjustment remote commander.
- 3) Turn on the HOLD switch of the adjustment remote commander.
- 4) Select page: 0, address: 01, and set data: 01.
- 5) Select page: F, address: 22, set data: 88, and press the PAUSE button of the adjustment remote commander.
(Be sure to perform “Processing after operation” after completing adjustments.)
- 6) Connect the oscilloscope to CPC jig for BX/BK.
Channel 1: PB RF (MON)
External trigger: SWP
- 7) Playback the alignment tape for tracking. (WR5-1NP (NTSC), WR5-1CP (PAL))
- 8) Check that the oscilloscope RF waveform is normal at the entrance and exit.
If not normal, adjust according to the separate volume “8mm Video Mechanical Adjustment Manual VII [B Mechanism]”.
- 9) Perform “Processing after operations”, after completing adjustment.

Test point of CPC jig for BX/BK

Pin No.	Signal Name	Pin No.	Signal Name
3	BL	1	EVF VCO
7	EVF VG	5	BL 4.75
9	PB RF (MON)		
13	BPF MONI	10	GND
17	TMS	15	REC RF (RF IN)
20	TDI	19	TDO
16	SWP	18	TCK
8	CAP FG	14	IR VIDEO

Note: Pin No. are those of CN713 or CPC connector.

Table 5-2-1.

[Procedure after operations]

- 1) Connect the adjustment remote commander, and turn on the HOLD switch.
- 2) Select page: 0, address: 01, and set data: 01.
- 3) Select page: F, address: 22, set data: 80, and press the PAUSE button of the adjustment remote commander.
- 4) Select page: 0, address: 01, and set data: 00.
- 5) Remove the power supply from the unit.

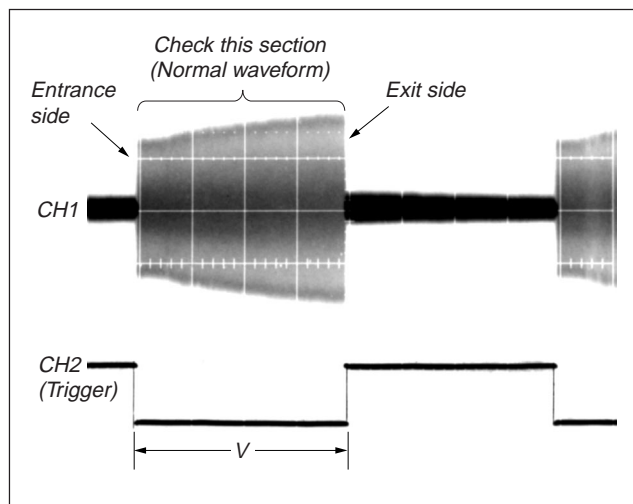

Fig. 5-2-1.

5-3. VIDEO SECTION ADJUSTMENTS

3-1. PREPARATIONS BEFORE ADJUSTMENTS

Use the following measuring instruments for video section adjustments.

3-1-1. Equipment to Required

- 1) TV monitor
- 2) Oscilloscope (dual-phenomenon, band width above 30 MHz with delay mode) (Unless specified otherwise, use a 10 : 1 probe.)
- 3) Frequency counter
- 4) Pattern generator with video output terminal
- 5) Digital voltmeter
- 6) Audio generator
- 7) Audio level meter
- 8) Audio distortion meter
- 9) Audio attenuator
- 10) Regulated power supply
- 11) NTSC alignment tapes
 - For tracking adjustment (WR5-1NP)
Parts code : 8-967-995-02
 - For video frequency characteristics adjustment (WR5-7NE)
Parts code : 8-967-995-13
 - For checking Standard 8 mode operations
 - For LP (WR5-4NL)
Parts code : 8-967-995-51
 - For SP (WR5-5NSP)
Parts code : 8-967-995-42
 - Note:** The following alignment tapes can also be used.
WR5-4NSP (8-967-995-41)
 - For checking Hi8 mode operations
 - For LP (WR5-8NLE)
Parts code : 8-967-995-52
 - For SP (WR5-8NSE)
Parts code : 8-967-995-43
 - For BPF adjustment (WR5-11NS)
Parts code : 8-967-995-71
- 12) PAL alignment tapes
 - For tracking adjustment (WR5-1CP)
Parts code : 8-967-995-07
 - For video frequency characteristics adjustment (WR5-7CE)
Parts code : 8-967-995-18
 - For checking Standard 8 mode operations
 - For LP (WR5-4CL)
Parts code : 8-967-995-56
 - For SP (WR5-5CSP)
Parts code : 8-967-995-47
 - Note:** The following alignment tapes can also be used.
 - 1) WR5-3CL (8-967-995-36)
 - 2) WR5-4CSP (8-967-995-46)
 - For checking Hi8 mode operations
 - For LP (WR5-8CLE)
Parts code : 8-967-995-57
 - For SP (WR5-8CSE)
Parts code : 8-967-995-48
 - For BPF adjustment (WR5-11CS)
Parts code : 8-967-995-76
- 13) Adjustment remote commander (J-6082-053-B)
- 14) CPC jig for BX/BK (J-6082-521-A)
- 15) IR receiver jig (J-6082-383-A)

3-1-2. Precautions on Adjusting

- 1) Connect the adjustment remote commander to CN713 of VC-251 board or CPC connector of FP-262 flexible via CPC jig for BX/BK (J-6082-521-A). To operate the adjustment remote commander, connect the AC power adapter to the DC IN jack of CPC jig for BX/BK, or connect the L series Info-LITHIUM battery to the battery terminal of CPC jig for BX/BK.
- 2) The adjustments of this unit are performed in the VTR mode or camera mode.

To set to the VTR mode, set the power switch to "PLAYER" or set the "Forced VTR Power ON mode" using the adjustment remote commander (Note3).

To set to the Camera mode, set the power switch to "CAMERA" or set the "Forced Camera Power ON mode" using the adjustment remote commander (Note4).

After completing adjustments, be sure to exit the "Forced VTR Power ON Mode" or "Forced Camera Power ON Mode". (Note6)
- 3) The front panel block (MI-040/041 board, microphone unit, video light) need not be connected except during "IR transmitter adjustment (CCD-TRV98)". To remove, disconnect the following connector.

MI-040/041 board CN754 (24P 0.5mm)
- 4) As removing the cabinet (R) assembly (removing CN709 of the VC-251 board) means removing the lithium 3V power supply (CF-1000 block/CF-077 board BT101), data such as date, time, user-set menus will be lost. After completing adjustments, reset these data. If the cabinet (R) assembly has been removed, the self-diagnosis data, data on history of use (total drum rotation time etc.) will be lost. Before removing, note down the self-diagnosis data (data of page: 2, address: B0 to C6) and the data on history use (data of page: 2, address: A2 to AA and E0 to E2). (Refer to "5-4.Service Mode".)
- 5) The cabinet (R) assembly (CF-077 board (TR model), CF-1000 block, LCD block (TRV model)) need not be connected to operate the VTR block. When removing the cabinet (R) assembly, disconnect the following connectors.
 1. VC-251 board CN709 (24P, 0.5mm)
 2. VC-251 board CN701 (20P, 0.8mm) (TRV model)
- 6) The lens block (CD-281/286 board) need not be connected. To remove, disconnect the following connectors.
 1. VC-251 board CN271 (14P, 0.5mm)
 2. VC-251 board CN291 (24P, 0.5mm)
- 7) The EVF block (VF-129/144 board) need not be connected. To remove, disconnect the following connectors.
 1. VC-251 board CN715 (4P, 1.0mm) (B/W EVF model)
 2. VC-251 board CN708 (20P, 0.5mm) (Color EVF model)
- 8) By setting the "Forced VTR Power ON mode" or "Forced Camera Power ON mode", the video section can be operate even if the control switch block (SS-1000) has been removed. When removing the control switch block (SS-1000), disconnect the following connector.

VC-251 board CN711 (5P 0.8mm)

- Note1:** TRV model:
CCD-TRV49/TRV49E/TRV58/TRV58E/TRV59E/TRV68/
TRV78/TRV78E/TRV88/TRV98/TRV98E
TR model:
CCD-TR618/TR618E/TR718E/TR728E/TR818
Color EVF model:
CCD-TR818
B/W EVF model:
CCD-TR618/TR618E/TR718E/TR728E/TRV49/TRV49E/
TRV58/TRV58E/TRV59E/TRV68/TRV78/TRV78E/TRV88/
TRV98/TRV98E
- Note2:** MI-040 board, CF-1000 block, CD-281 board: TRV model
MI-041 board, CF-077 board, CD-286 board: TR model
VF-129 board: B/W EVF model
VF-141 board: Color EVF model
- Note3:** Setting the "Forced VTR Power ON" mode (VTR mode)
1) Select page: 0, address: 01, and set data: 01.
2) Select page: D, address: 10, set data: 02, and press the PAUSE button.
The above procedure will enable the VTR power to be turned on with the control switch block (SS-1000) removed.
After completing adjustments, be sure to exit the "Forced VTR Power ON mode".
- Note4:** Setting the "Forced Camera Power ON" mode (Camera mode)
1) Select page: 0, address: 01, and set data: 01.
2) Select page: D, address: 10, set data: 01, and press the PAUSE button.
The above procedure will enable the camera power to be turned on with the control switch block (SS-1000) removed.
After completing adjustments, be sure to exit the "Forced Camera Power ON mode".
- Note5:** Exiting the "Forced Power ON" mode
1) Select page: 0, address: 01, and set data: 01.
2) Select page: D, address: 10, set data: 00, and press the PAUSE button.
3) Select page: 0, address: 01, and set data: 00.

3-1-3. Adjusting Connectors

Some of the adjusting points of the video section are concentrated in CN713 of VC-251 board or CPC connector of FP-262 flexible. Connect the Measuring instruments and the adjustment remote commander via the CPC jig for BX/BK (J-6082-521-A) to CN713 or CPC connector. To operate the adjustment remote commander, connect the AC power adapter to the DC IN jack of CPC jig for BX/BK, or connect the L series Info-LITHIUM battery to the battery terminal of CPC jig for BX/BK.

The following table shows the Pin No. and signal name of CN713 or CPC connector.

Pin No.	Signal Name	Pin No.	Signal Name
1	VCO	2	XLANC POWER ON
3	EVF BL	4	LANC IN
5	EVF BL 4.75V	6	LANC OUT
7	EVF VG	8	CAP FG
9	PB RF	10	REG GND
11	REG GND	12	REG GND
13	BPF MONI	14	IR VIDEO
15	REC RF	16	RF SWP
17	NC	18	NC
19	NC	20	NC

Table 5-3-1.

The following table shows the arrangement of the test points of CPC jig for BX/BK. (Pin No. are those of CN713 or CPC connector.)

Pin No.	Signal Name	Pin No.	Signal Name
3	BL	1	EVF VCO
7	EVF VG	5	BL 4.75
9	PB RF (MON)		
13	BPF MONI	10	GND
17	TMS	15	REC RF (RF IN)
20	TDI	19	TDO
16	SWP	18	TCK
8	CAP FG	14	IR VIDEO

Table 5-3-2.

[TRV model]

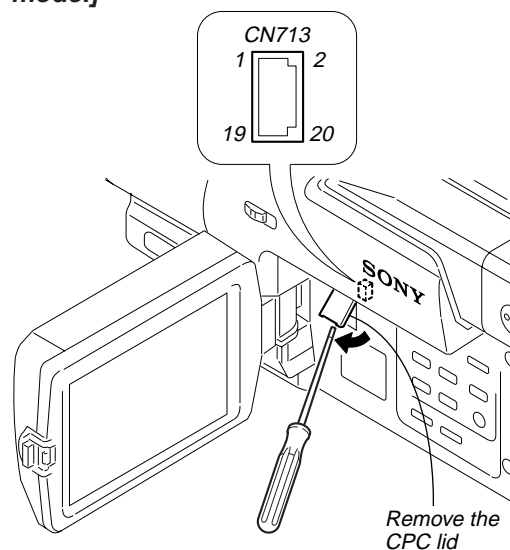

[TR model]

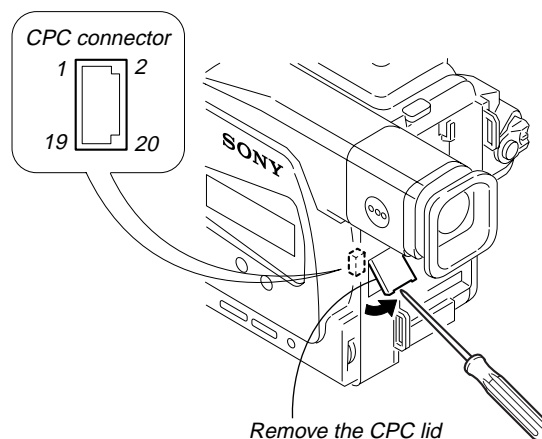

Fig. 5-3-1.

3-1-4. Connecting the Equipment

Connect the measuring instruments as shown in Fig. 5-3-2 and perform the adjustments.

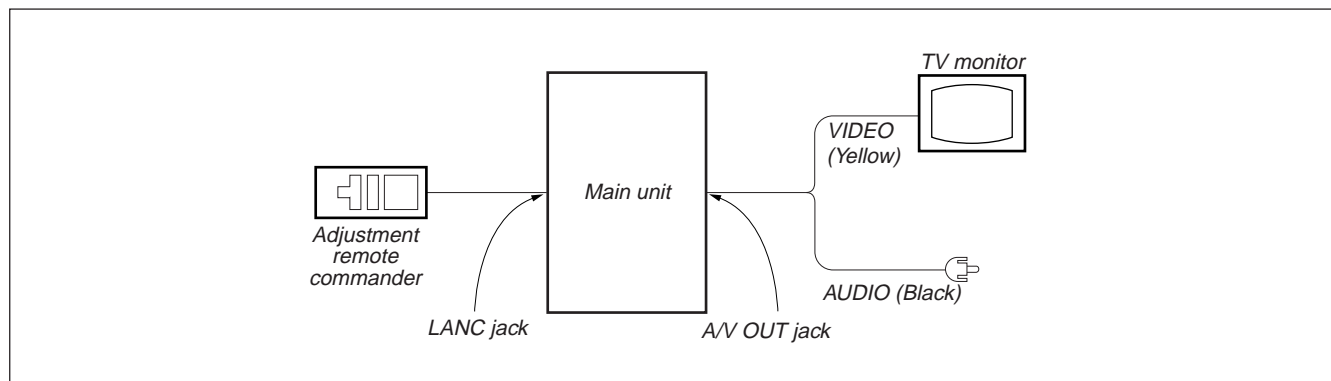

Fig. 5-3-2.

3-1-5. Alignment Tape

The following table lists alignment tapes which are available.

Use the tape specified in the signal column for each adjustment. If the type of tape to be used for checking operations is not specified, use whichever type.

Alignment tape

Name	Recording mode	Tape type	Tape speed	Usage
Tracking (WR5-1NP(NTSC), WR5-1CP(PAL))	Standard 8	MP	SP	Tape path adjustment, Switching position adjustment
Video frequency characteristics (WR5-7NE(NTSC), WR5-7CE(PAL))	Hi8	ME	SP (NTSC) LP (PAL)	Frequency characteristics adjustment
Operation check (WR5-5NSP(NTSC), WR5-5CSP(PAL))	Standard 8	MP	SP	Operation check
Operation check (WR5-8NSE(NTSC), WR5-8CSE(PAL))	Hi8	ME	SP	
Operation check (WR5-4NL(NTSC), WR5-4CL(PAL))	Standard 8	MP	LP	
Operation check (WR5-8NLE(NTSC), WR5-8CLE(PAL))	Hi8	ME	LP	
BPF adjustment (WR5-11NS(NTSC), WR5-11CS(PAL))	Standard 8	MP	SP	

Tape type:

- ME Particle type metal tape
- MP Evaporated type metal tape

Table. 5-3-3.

Fig.5-3-3. shows the 75% color bar signals recorded on the alignment tape.

Note: Measure using the VIDEO terminal (Terminated at 75Ω).

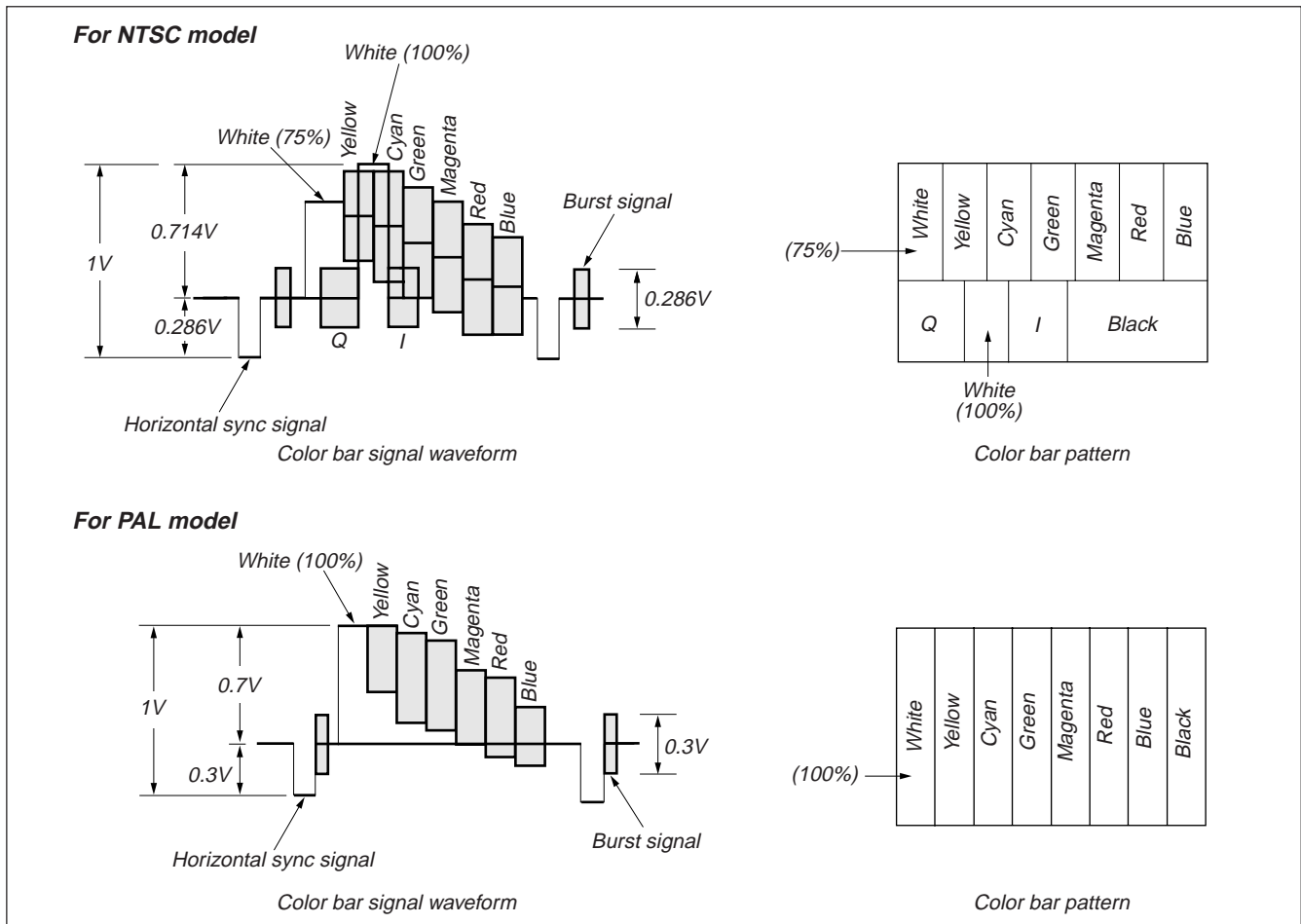

Fig. 5-3-3. Color bar signal of alignment tapes

3-1-6. Output Level and Impedance

Video output

Stereo minijack,
1Vp-p, 75Ω, unbalanced, sync negative

S video output

4-pin mini DIN

Luminance signal:

1Vp-p, 75Ω, unbalanced, sync negative

Chrominance signal:

0.286Vp-p, 75Ω, unbalanced (NTSC)

0.300Vp-p, 75Ω, unbalanced (PAL)

Audio output

Stereo minijack:

-7.5dBs, (at load impedance 47kΩ), impedance less than
2.2kΩ

3-1-7. Recording Mode (Standard 8/Hi8) switching

The record mode (Standard 8/Hi8) of this unit switches as shown in the following table. The playback mode (Standard 8/Hi8) switches automatically according to the recording mode of the tape played back.

Tape Used	Recording Mode
ME	Hi8
Hi8 MP	
MP	Standard 8

3-2. SYSTEM CONTROL SYSTEM ADJUSTMENT

1. Initialization of D, E, F, 7 Page Data

If the D, E, F, 7 page data is erased due to some reason, perform “1-2. INITIALIZATION OF D, E, F, 7 PAGE DATA”, of “5-1. CAMERA SECTION ADJUSTMENT”

3-3. SERVO SYSTEM ADJUSTMENT

1. CAP FG Offset Adjustment (VC-251 board)

Set the Cap FG signal duty cycle to 50% to establish an appropriate capstan servo. If deviated, the uneven rotation of capstan and noise can occur in the LP mode.

Mode	Camera recording (SP mode)
Subject	Arbitrary
Measurement Point	CAP FG (Pin ⑧ of CN713 or Pin ⑧ of CPC connector of FP-262 flexible)
Measuring Instrument	Oscilloscope
Adjustment Page	F
Adjustment Address	64
Specified value	Duty = $50 \pm 1 \%$

Adjusting method:

Order	Page	Address	Data	Procedure
1	0	01	01	Set the data.
2	6	01	81	Set the data, and press PAUSE button.
3	6	02		Check that the data changes to “01”.
4	6	01	00	Set the data, and press PAUSE button.
5				Check that Duty of CAP FG signal satisfies the specified value. If not, repeat steps 2 to 4.
6	0	01	01	Set the data.

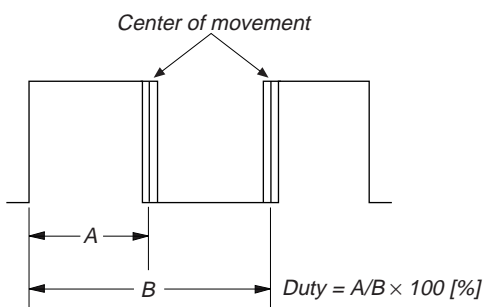

Fig. 5-3-4.

2. Switching Position Adjustment (VC-251 Board)

If deviated in this case causes switching noise or jitter on the played back screen.

Mode	Playback
Signal	Alignment tape: For tracking adjustment (WR5-1NP (NTSC)) (WR5-1CP (PAL))
Measurement Point	CH1: SWP (Pin ⑩ of CN713 or Pin ⑩ of CPC connector of FP-262 flexible) CH2: PB RF (Pin ⑨ of CN713 or Pin ⑨ of CPC connector of FP-262 flexible)
Measuring Instrument	Oscilloscope
Adjustment Page	F
Adjustment Address	62, 63
Specified Value	$t_1 = 0 \pm 10 \mu\text{sec}$

Note: NTSC model: CCD-TR618/TR818/TRV49/TRV58/TRV68/TRV78/TRV88/TRV98

PAL model: CCD-TR618E/TR718E/TR728E/TRV49E/TRV58E/TRV59E/TRV78E/TRV98E

Adjusting Method:

Order	Page	Address	Data	Procedure
1	0	01	01	Set the data.
2	F	22	C0	Set the data, and press PAUSE button.
3	F	62		Change the data and minimize “t1”. (Coarse adjustment)
4	F	62		Press PAUSE button
5	F	63		Change the data and adjust so that the switching position (t1) becomes the specified value. (Fine adjustment)
6	F	63		Press PAUSE button
7	F	22	80	Set the data, and press PAUSE button.
8	0	01	01	Set the data.

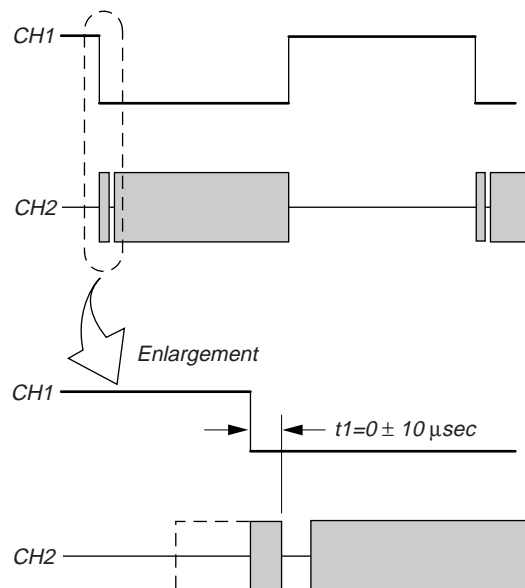

Fig. 5-3-5.

3-4. VIDEO SYSTEM ADJUSTMENTS

Video system adjustments must be performed in the following order.

Note: NTSC model: CCD-TR618/TR818/TRV49/TRV58/TRV68/TRV78/TRV88/TRV98

PAL model: CCD-TR618E/TR718E/TR728E/TRV49E/TRV58E/TRV59E/TRV78E/TRV98E

[Adjusting Order]

1. 28MHz origin oscillation adjustment
2. AFC fo adjustment
3. Filter fo adjustment
4. Y OUT level adjustment
5. C OUT level adjustment
6. REC Y current adjustment
7. REC C/REC AFM current adjustment

1. 28 MHz Origin Oscillation Adjustment (VC-251 board)

Set the frequency of the clock for synchronization.

If deviated, the synchronization will be disrupted and the color will become inconsistent.

Mode	VTR stop
Signal	No signal
Measurement Point	R200 (Pin ⑦ of IC151)
Measuring Instrument	Frequency counter
Adjustment Page	F
Adjustment Address	4D
Specified Value	f=3579545 ± 17Hz (NTSC) f=4433594 ± 17Hz (PAL)

Adjusting method:

Order	Page	Address	Data	Procedure
1	0	01	01	Set the data.
2	6	61	30	Set the data.
3	2	01	41	Set the data, and press PAUSE button.
4	F	4D		Change the data and set the frequency (f) to the specified value.
5	F	4D		Press PAUSE button.
6	2	01	00	Set the data, and press PAUSE button.
7	6	61	10	Set the data.
8	0	01	00	Set the data.

VC-251 BOARD

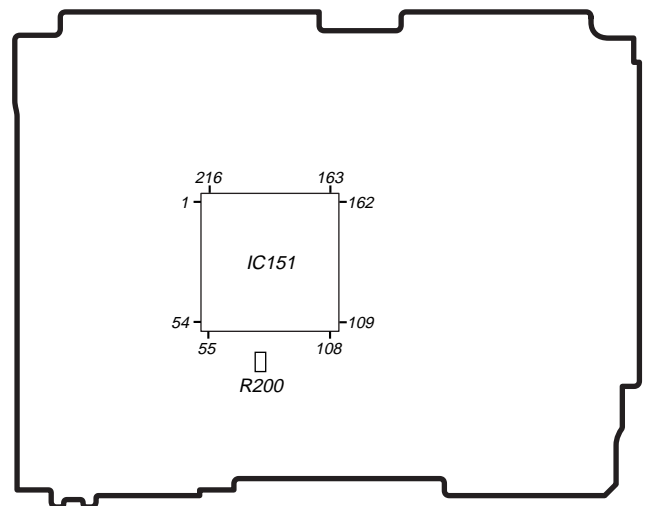

2. AFC fo Adjustment (VC-251 board)

Adjust the pull-in range of the A/D converted clock generator during playback.

Mode	VTR stop
Signal	No signal
Adjustment Page	F
Adjustment Address	65

Adjusting method:

Order	Page	Address	Data	Procedure
1	0	01	01	Set the data.
2	F	65	50	Set the data, and press PAUSE button.
3	2	01	4D	Set the data, and press PAUSE button.
4				Wait for 0.5 sec.
5	6	01	C5	Set the data, and press PAUSE button.
6	6	02		Check that the data changes to "01". (Note)
7	2	01	00	Set the data, and press PAUSE button.
8	6	01	00	Set the data, and press PAUSE button.
9	0	01	00	Set the data.

Note: The adjustment data will be automatically input to page: F, address: 65.

3. Filter fo Adjustment (VC-251 board)

Adjust the fo frequency of the IC151 built-in filter.

Mode	VTR stop
Signal	No signal
Measurement Point	IR VIDEO (Pin ⑭ of CN713 or Pin ⑭ of CPC connector of FP-262 flexible)
Measuring Instrument	Oscilloscope
Adjustment Page	F
Adjustment Address	66
Specified Value	Minimum residual chroma signal components (A= Bellow 35mV)

Adjusting method:

Order	Page	Address	Data	Procedure
1	0	01	01	Set the data.
2	2	01	4F	Set the data, and press PAUSE button.
3	2	05	40	Set the data,.
4	F	66		Change the data and minimize the residual chroma signal components (A). (The data should be "70" to "7F".)
5	F	66		Press PAUSE button.
6	2	01	00	Set the data, and press PAUSE button.
7	2	05	00	Set the data,.
8	0	01	00	Set the data.

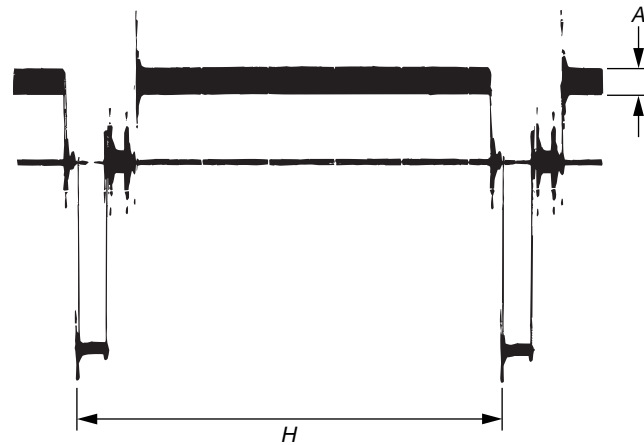

Fig. 5-3-6.

4. Y OUT Level Adjustment (VC-251 board)

Set the Y signal output level. (Adjust the D/A converter output level of IC151.)

Mode	VTR stop
Signal	No signal
Measurement Point	Y signal terminal of S VIDEO terminal (75Ω terminated)
Measuring Instrument	Oscilloscope
Adjustment Page	F
Adjustment Address	67
Specified Value	A=286 ± 5mV (NTSC) A=300 ± 5mV (PAL)

Note1: Insert a plug into the S video terminal.

Adjusting method:

Order	Page	Address	Data	Procedure
1	0	01	01	Set the data.
2	2	01	41	Set the data, and press PAUSE button.
3	6	61	30	Set the data,.
4	F	67		Change the data and set the SYNC level (A) to the specified value.
5	F	67		Press PAUSE button.
6	2	01	00	Set the data, and press PAUSE button.
7	6	61	10	Set the data.
8	0	01	00	Set the data.

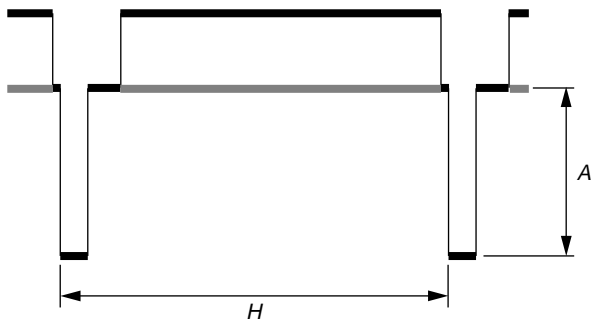

Fig. 5-3-7.

5. C OUT Level Adjustment (VC-251 board)

Set the chroma signal output level. (Adjust the D/A converter output level of IC151.)

Mode	VTR stop
Signal	No signal
Measurement Point	Chroma signal terminal of S VIDEO terminal (75Ω terminated)
Measuring Instrument	Oscilloscope
Adjustment Page	F
Adjustment Address	68
Specified Value	A=286 ± 5mV (NTSC) A=300 ± 5mV (PAL)

Note1: Insert a plug into the S video terminal.

Adjusting method:

Order	Page	Address	Data	Procedure
1	0	01	01	Set the data.
2	2	01	41	Set the data, and press PAUSE button.
3	6	61	30	Set the data,.
4	F	68		Change the data and set the burst level (A) to the specified value.
5	F	68		Press PAUSE button.
6	2	01	00	Set the data, and press PAUSE button.
7	6	61	10	Set the data,.
8	0	01	00	Set the data.

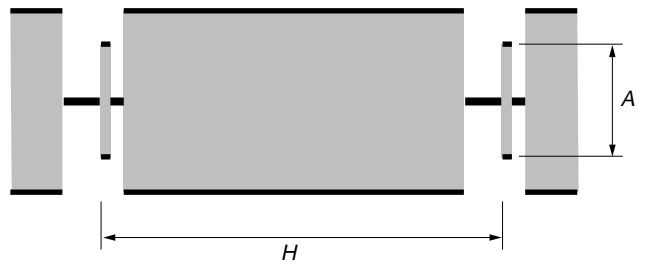

Fig. 5-3-8.

6. REC Y Current Adjustment (VC-251 board)

Adjust the Y FM signal recording current.

Mode	VTR recording (SP mode)	
Signal	No signal	
Measurement Point	REC RF (Pin ⑮ of CN713 or Pin ⑮ of CPC connector of FP-262 flexible)	
Measuring Instrument	Oscilloscope (20 MHz BW LIMIT: OFF)	
Adjustment Page	F	7
Adjustment Address	6A, 6B	F9
Specified Value	A=235 ± 5mV (NTSC) A=280 ± 5mV (PAL)	

Note1: Don't disconnect the DC power supply of the camcorder during the following adjustments.

When the following symptom occurs, reset the data of D page to the values written down.

- 1) The power is shut off so that unit cannot operate.

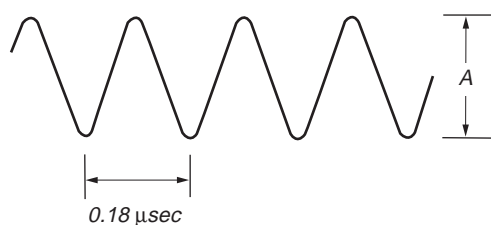

Fig. 5-3-9.

Adjusting method:

Order	Page	Address	Data	Procedure
1				Set to the stop mode.
2	0	01	01	Set the data.
3	D	14		Write down the data.
4	D	14		Set the following data, and press PAUSE button. 06 (NTSC), 26 (PAL)
5	D	15		Write down the data.
6	D	15		Set the following data, and press PAUSE button. 6D (NTSC), 6F (PAL)
7				Set to VTR recording mode. (Note2)
8	E	FB		Write down the data.
9	E	FB	06	Set the data, and press PAUSE button.
10	F	71		Write down the data.
11	F	71	00	Set the data, and press PAUSE button.
12	2	01	41	Set the data, and press PAUSE button.
13	6	63	01	Set the data.
14	F	6B		Change the data and set the Y signal level (A) to the specified value.
15	F	6B		Read the data, and this data is named D _{6B} .
16	F	6A	D _{6B}	Set the data, and press PAUSE button.
17				Convert D _{6B} to decimal notation, and obtain D _{6B} '. (Note3)
18				Calculate D _{F9} ' using following equations (Decimal calculation) When D _{6B} ' ≤ 243 D _{F9} ' = D _{6B} ' + 12 When D _{6B} ' > 243 D _{F9} ' = 255
19				Convert D _{F9} ' to a hexadecimal number, and obtain D _{F9} . (Note3)
20	7	F9	D _{F9}	Set the data, and press PAUSE button.
21	6	63	00	Set the data.
22	2	01	00	Set the data, and press PAUSE button.
23	F	71		Set the data written down at step 10, and press PAUSE button.
24	E	FB		Set the data written down at step 8, and press PAUSE button.
25	D	14		Set the data written down at step 3, and press PAUSE button.
26	D	15		Set the data written down at step 5, and press PAUSE button.
27	0	01	00	Set the data.

Note2: Use the REC buttons of the adjustment remote commander (with the HOLD switch set in the OFF position).

Note3: Refer to "Table 5-4-1. Hexadecimal-decimal Conversion Table".

7. REC C/AFM Current Adjustment

7-1. Preparations

Order	Page	Address	Data	Procedure
1	0	01	01	Set the data.
2	D	14		Write down the data.
3	D	14		Set the following data, and press PAUSE button. 06 (NTSC), 26 (PAL)
4	D	15		Write down the data.
5	D	15		Set the following data, and press PAUSE button. 6D (NTSC), 6F (PAL)

Note: Don't disconnect the DC power supply of the camcorder during the following adjustments.

When the following symptom occurs, reset the data of D page to the values written down.

1) The power is shut off so that unit cannot operate.

7-2. REC C Current Check (VC-251 board)

Check the recording current level of the REC Chroma signal. If it is too low, chroma signal noise in played back picture will be increased. If too high, Y signal noises will increase and white modulation noises will be produced.

Mode	VTR recording (SP mode)
Signal	No signal
Measurement Point	REC RF (Pin ⑮ of CN713 or Pin ⑮ of CPC connector of FP-262 flexible)
Measuring Instrument	Oscilloscope (20 MHz BW LIMIT: OFF)
Specified Value	A=50.8 ± 3.0mV (NTSC) A=54.0 ± 3.0mV (PAL)

Adjusting method:

Order	Page	Address	Data	Procedure
1				Insert a Hi8 ME tape, and set to VTR recording mode. (Note)
2	0	01	01	Set the data.
3	2	01	41	Set the data, and press PAUSE button.
4	6	61	30	Set the data.
5	E	FB		Write down the data.
6	E	FB	05	Set the data, and press PAUSE button.
7	F	71		Write down the data.
8	F	71	00	Set the data, and press PAUSE button.
9				Check that the REC chroma signal level (A) satisfies the specified value, and write down the signal level.
10	F	71		Set the data written down at step 7, and press PAUSE button.
11	E	FB		Set the data written down at step 5, and press PAUSE button.
12	6	61	10	Set the data.
13	2	01	00	Set the data, and press PAUSE button.
14	0	01	00	Set the data.
15				Perform "REC AFM Current Adjustment" and "Processing after completed adjustment".

Note: Use the REC buttons of the adjustment remote commander (with the HOLD switch set in the OFF position).

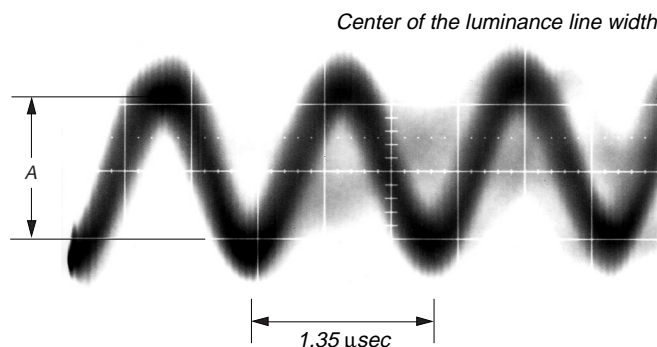

Fig. 5-3-10.

7-3. REC AFM Current Adjustment (VC-251 board)

Set the recording levels of the REC AFM signal. If the level is too low, the audio S/N will be deteriorated. If too high, color beats will be produced on the self-recording / playback image.

Mode	VTR recording (SP mode)
Signal	No signal
Measurement Point	REC RF (Pin ⑮ of CN713 or Pin ⑮ of CPC connector of FP-262 flexible)
Measuring Instrument	Oscilloscope (20 MHz BW LIMIT: OFF)
Adjustment Page	F
Adjustment Address	71
Specified Value	NTSC model: A= (REC Chroma signal level) × 0.292 ± 0.9mV (Note) PAL model: A= (REC Chroma signal level) × 0.309 ± 0.9mV (Note)

Note1: REC chroma signal level is written down at step 9 of "REC C Current Check".

Adjusting method:

Order	Page	Address	Data	Procedure
1				Insert a Hi8 ME tape, and set to recording mode. (Note2)
2	0	01	01	Set the data.
3	2	01	41	Set the data, and press PAUSE button.
4	E	FB		Write down the data.
5	E	FB	07	Set the data, and press PAUSE button.
6	F	71		Change the data and set the REC AFM signal level (A) to the specified value.
7	F	71		Press PAUSE button.
8	E	FB		Set the data written down at step 4, and press PAUSE button.
9	2	01	00	Set the data, and press PAUSE button.
10	0	01	00	Set the data.
11				Perform "Processing after completed adjustment".

Note2: Use the REC buttons of the adjustment remote commander (with the HOLD switch set in the OFF position).

7-4. Processing after completed adjustment

Order	Page	Address	Data	Procedure
1	0	01	01	Set the data.
2	D	14		Set the data written down at step 2 of "7-1. Preparations", and press PAUSE button.
3	D	15		Set the data written down at step 4 of "7-1. Preparations", and press PAUSE button.
4	0	01	00	Set the data.

Center of the luminance line width

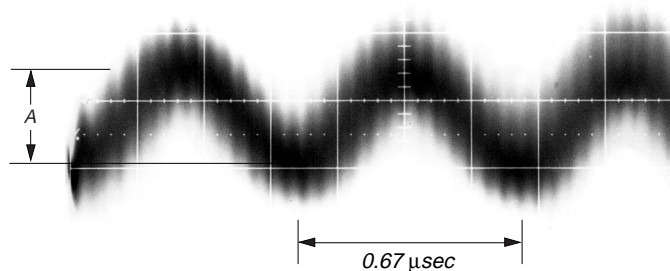

Fig. 5-3-11.

3-5. IR TRANSMITTER ADJUSTMENTS (CCD-TRV98)

Adjust using the IR receiver jig (J-6082-383-A).

Note: If the distance between the IR receiver jig and the camcorder is below 1m, cover the LASER LINK emitter with a ND filter. (For example, when the distance is 30cm to 50cm, cover the LASER LINK emitter with a ND filter 1.0.)

Switch setting:

LASER LINK ON (Red LED is lit)

1. IR Video Carrier Frequency Adjustment (MI-041 board)

Mode	VTR stop
Signal	Arbitrary
Measurement Point	Pin ⑤ of CN003 of IR receiver jig (RF) (Or Pin ⑩ of IC3901 of MI-041 board)
Measuring Instrument	Frequency counter
Adjustment Page	F
Adjustment Address	80
Specified Value	f = 11.85 ± 0.05 MHz (*1) f = 11.55 ± 0.05 MHz (*2)

*1: IC3901 of MI-041 board is LA9511.

*2: IC3901 of MI-041 board is AN2920.

Connection of Equipment:

Connect the measuring device as shown in the following figure, and adjust.

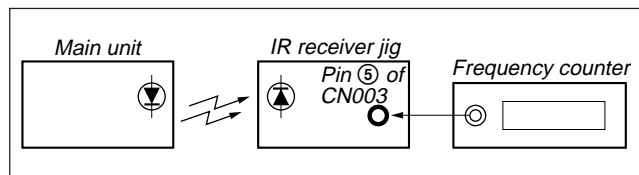

Fig. 5-3-12.

Adjusting method:

Order	Page	Address	Data	Procedure
1	0	01	01	Set the data.
2	2	01	37	Set the data, and press PAUSE button.
3	F	80		Change the data, and set the video carrier frequency (f) to the specified value.
4	F	80		Press PAUSE button.
5	2	01	00	Set the data, and press PAUSE button.
6	0	01	00	Set the data.

2. IR Video Deviation Adjustment (MI-041 board)

Mode	VTR stop
Signal	Arbitrary
Measurement Point	VIDEO OUT terminal of IR receiver jig (Terminated at 75Ω)
Measuring Instrument	Oscilloscope
Adjustment Page	F
Adjustment Address	7E
Specified Value	A = 0.87 ± 0.05 V

Connection of Equipment:

Connect the measuring device as shown in the following figure, and adjust.

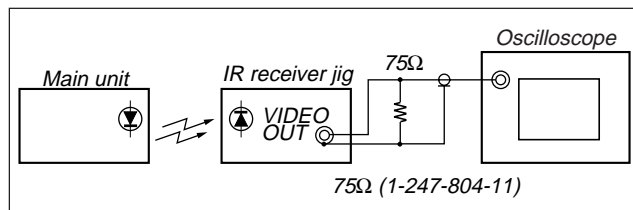

Fig. 5-3-13.

Adjusting method:

Order	Page	Address	Data	Procedure
1	0	01	01	Set the data.
2	2	01	39	Set the data, and press PAUSE button.
3	F	7E		Change the data, set the video signal amplitude (A) to the specified value.
4	F	7E		Press PAUSE button.
5	2	01	00	Set the data, and press PAUSE button.
6	0	01	00	Set the data.

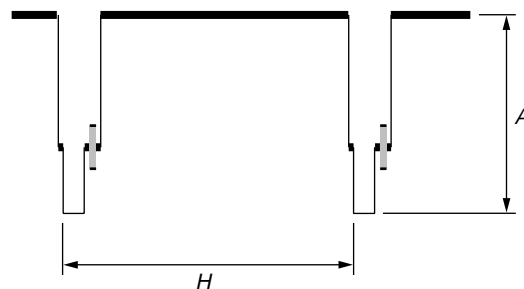

Fig. 5-3-14.

3. IR Audio Deviation Adjustment (MI-041 board)

Mode	Playback
Signal	Alignment tape: For checking operation (WR5-5NSP(NTSC))
Measurement Point	AUDIO L terminal and AUDIO R terminal of IR receiver jig (Terminated at 47kΩ)
Measuring Instrument	Audio level meter
Adjustment Page	F
Adjustment Address	7F
Specified Value	Signal level: -7.5 ± 2.0 dBs

Note: This adjustment should be carried out upon completion of the audio system adjustments.

Connection of Equipment:

Connect the measuring device as shown in the following figure, and adjust.

Adjusting method:

Order	Page	Address	Data	Procedure
1	0	01	01	Set the data.
2				Connect the audio level meter to the AUDIO L terminal of the IR receiver jig.
3	F	7F		Change the data and set the 400Hz audio signal level to the specified value.
4	F	7F		Press PAUSE button.
5				Connect the audio level meter to the AUDIO R terminal of the IR receiver jig.
6	F	7F		Check that the 400Hz audio signal level is within the specified value. If outside, repeat from step 2.
7	0	01	00	Set the data.

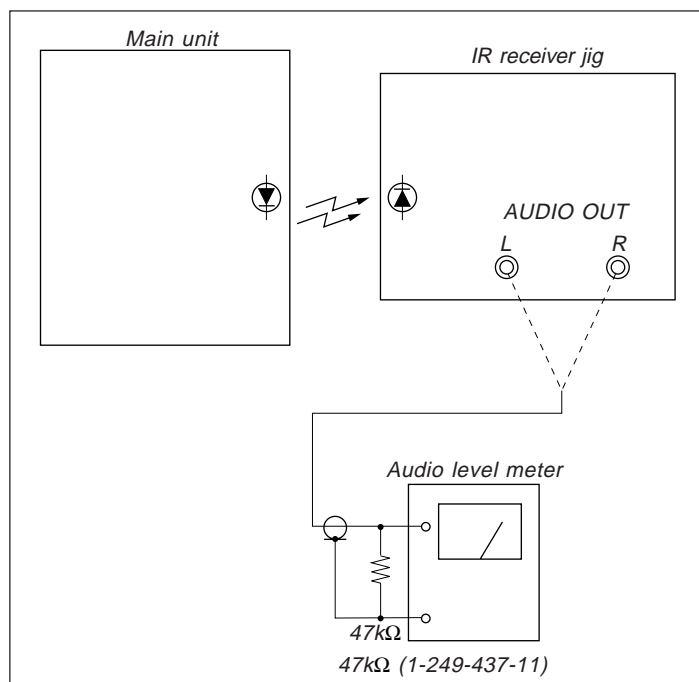

Fig. 5-3-15.

3-6. AUDIO SYSTEM ADJUSTMENTS

[Connecting the measuring instruments for the audio]

Connect the audio system measuring instruments in addition to the video system measuring instruments as shown in Fig. 5-3-16.

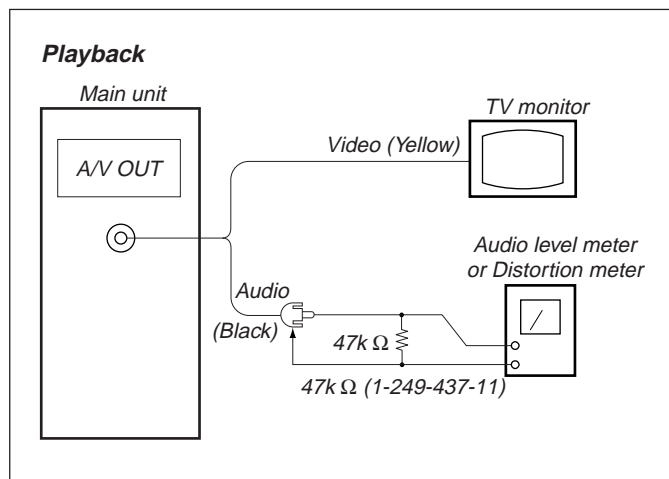

Fig. 5-3-16.

1. 1.5MHz Deviation Adjustment (VC-251 board)

Adjust to the optimum 1.5MHz audio FM signal deviation. If the adjustment is not correct, its playback level will differ from that of other units.

Mode	Playback
Signal	Alignment tape: For checking operation (WR5-5NSP (NTSC)) (WR5-5CSP (PAL))
Measurement Point	Audio terminal of A/V OUT jack
Measuring Instrument	Audio level meter
Adjustment Page	F
Adjustment Address	7B
Specified Value	-7.5 ± 2.0 dBs

Adjusting method:

Order	Page	Address	Data	Procedure
1	0	01	01	Set the data.
2	F	7B		Change the data and set the 400Hz audio signal level to the specified value.
3	F	7B		Press PAUSE button.
4	0	01	00	Set the data.

2. BPF fo Adjustment (VC-251 board)

Sets the BPF passing frequency of IC760 so that the AFM signal can separate from the playback RF signal properly. If deviated, the mono/stereo mode will be differentiated incorrectly, and noises and distortions will increase during high volume playback.

Mode	Playback
Signal	Alignment tape: For BPF adjustment (WR5-11NS (NTSC)) (WR5-11CS (PAL))
Measurement Point	Audio terminal of A/V OUT jack
Measuring Instrument	Distortion meter
Adjustment Page	F
Adjustment Address	7D
Specified Value	The distortion rate should be minimum.

Adjusting method:

Order	Page	Address	Data	Procedure
1	0	01	01	Set the data.
2	F	7D		Change the data and minimize the distortion rate.
3	F	7D		Press PAUSE button.
4	0	01	00	Set the data.

5-4. SERVICE MODE

4-1. ADJUSTMENT REMOTE COMMANDER

The adjustment remote commander is used for changing the calculation coefficient in signal processing, EVR data, etc. The adjustment remote commander performs bi-directional communication with the unit using the remote commander signal line (LANC). The resultant data of this bi-directional communication is written in the non-volatile memory.

1. Using the Adjustment Remote Commander

- 1) Connect the adjustment remote commander to CN713 of VC-251 board or CPC connector of FP-262 flexible via CPC jig for BX/BK (J-6082-521-A). To operate the adjustment remote commander, connect the AC power adapter (8.4Vdc) to the DC IN jack of CPC jig for BX/BK, or connect the L series Info-LITHIUM battery to the battery terminal of CPC jig for BX/BK.
- 2) Set the HOLD switch of the adjustment remote commander to "HOLD" (SERVICE position). If it has been properly connected, the LCD on the adjustment remote commander will display as shown in Fig. 5-4-1.



Fig. 5-4-1.

- 3) Operate the adjustment remote commander as follows.
 - Changing the page
The page increases when the EDIT SEARCH+ button is pressed, and decreases when the EDIT SEARCH- button is pressed. There are altogether 16 pages, from 0 to F.

Hexadecimal notation	0 1 2 3 4 5 6 7 8 9 A B C D E F
LCD Display	0 1 2 3 4 5 6 7 8 9 A b c d e f
Decimal notation conversion value	0 1 2 3 4 5 6 7 8 9 10 11 12 13 14 15

- Changing the address
The address increases when the FF (▶▶) button is pressed, and decreases when the REW (◀◀) button is pressed. There are altogether 256 addresses, from 00 to FF.
 - Changing the data (Data setting)
The data increases when the PLAY (▶) button is pressed, and decreases when the STOP (■) button is pressed. There are altogether 256 data, from 00 to FF.
 - Writing the adjustment data
The PAUSE button must be pressed to write the adjustment data (D, E, F, 7 page) in the nonvolatile memory. (The new adjusting data will not be recorded in the nonvolatile memory if this step is not performed.)
- 4) After completing all adjustments, turn off the main power supply (8.4 V) once.

2. Precautions Upon Using the Adjustment Remote Commander

Mishandling of the adjustment remote commander may erase the correct adjustment data at times. To prevent this, it is recommended that all adjustment data be noted down before beginning adjustments and new adjustment data after each adjustment.

4-2. DATA PROCESS

The calculation of the DDS display and the adjustment remote commander display data (hexadecimal notation) are required for obtaining the adjustment data of some adjustment items. In this case, after converting the hexadecimal notation to decimal notation, calculate and convert the result to hexadecimal notation, and use it as the adjustment data. Indicates the hexadecimal-decimal conversion table.

Hexadecimal-decimal Conversion Table																②
Lower digit of hexadecimal Upper digit of hexadecimal	0	1	2	3	4	5	6	7	8	9	A (A)	B (b)	C (c)	D (d)	E (E)	F (F)
0	0	1	2	3	4	5	6	7	8	9	10	11	12	13	14	15
1	16	17	18	19	20	21	22	23	24	25	26	27	28	29	30	31
2	32	33	34	35	36	37	38	39	40	41	42	43	44	45	46	47
3	48	49	50	51	52	53	54	55	56	57	58	59	60	61	62	63
4	64	65	66	67	68	69	70	71	72	73	74	77	76	77	78	79
5	80	81	82	83	84	85	86	87	88	89	90	91	92	93	94	95
6	96	97	98	99	100	101	102	103	104	105	106	107	108	109	110	111
7	112	113	114	115	116	117	118	119	120	121	122	123	124	125	126	127
8	128	129	130	131	132	133	134	135	136	137	138	139	140	141	142	143
9	144	145	146	147	148	149	150	151	152	153	154	155	156	157	158	159
A (A)	160	161	162	163	164	165	166	167	168	169	170	171	172	173	174	175
① B (b)	176	177	178	179	180	181	182	183	184	185	186	187	188	189	190	191
C (c)	192	193	194	195	196	197	198	199	200	201	202	203	204	205	206	207
D (d)	208	209	210	211	212	213	214	215	216	217	218	219	220	221	222	223
E (E)	224	225	226	227	228	229	230	231	232	233	234	235	236	237	238	239
F (F)	240	241	242	243	244	245	246	247	248	249	250	251	252	253	254	255

Note: The characters shown in the parenthesis () shown the display on the adjustment remote commander.

(Example) If the DDS display or the adjustment remote commander shows BD (bd);
Because the upper digit of the adjustment number is B (b), and the lower digit is D (d), the meeting point “189” of ① and ② in the above table is the corresponding decimal number.

Table. 5-4-1.

4-3. SERVICE MODE

Note: After the completion of the all adjustments, cancel the service mode by either of the following ways.

- 1) Unplug the main power supply and remove the lithium battery. (In this case, date and time and menu setting have been set by users are canceled. Perform resetting.)
- 2) After data on page: D and F is restored, return data of the address: 01 on page: 0 to 00. And when data on page: 2 is changed, return the data to the original condition.

1. Test Mode Setting

Set/release each test mode. Set page: 0, address: 01, data: 01 before setting the data of page D and F.

Page F	Address 22
--------	------------

Data	Function
80	Normal
81	Test mode Various emergency prohibitions and releases Drum emergency, capstan emergency, loading motor emergency, reel emergency, tape top and end, DEW detection

Page D	Address 10
--------	------------

Data	Function
00	Normal
01	Camera power ON
02	VTR power ON
03	Camera + VTR power ON

- * For page D and F, the data set will be recorded in the nonvolatile memory by pressing the PAUSE button on the adjustment remote commander. Take note that, in this case, the test mode will not be released even if the main power has been turned off.
- * Be sure to return the data of page: F, address: 22 to 80, and the data of page: D, address: 10 to 00 after completing adjustments/repairs and press the PAUSE button of the adjustment remote commander. And set page: 0, address: 01, data: 00.

2. Emergency Memory Address

Page F	Address 10 to 1B
--------	------------------

Address	Contents
10	1st EMG code
12	Upper: MSW code when the mechanism starts shifting the 1st time Lower: MSW code when the 1st emergency occurs
13	Lower: Target MSW code of the 1st emergency occurs
14	2nd EMG code
16	Upper: MSW code when the mechanism starts shifting the 2nd time Lower: MSW code when the 2nd emergency occurs
17	Lower: Target MSW code of the 2nd emergency occurs
18	Last EMG code
1A	Upper: MSW code when the mechanism starts shifting the last time Lower: MSW code when the last emergency occurs
1B	Lower: Target MSW code of the last emergency occurs

When there are no emergency, data 00 will be written in the above addresses (10 to 1B). When the first emergency occurs, the data corresponding to the emergency will be written in the address (10 to 13) for this first emergency. In the same way, when the second emergency occurs, the data corresponding to the emergency will be written in the address (14 to 17) for this second emergency. The data corresponding to the emergency occurring the last will be written in the address (18 to 1B) for this last emergency. Therefore the data of addresses 18 to 1B are renewed each time an emergency occurs.

Note 1: Be sure to rewrite the data of addresses 10 to 1B to 00 after repairs/adjustments.

Note 2: When rewriting the data, be sure to press the PAUSE button of the remote commander after setting the data.

2-1. EMG code (Emergency code)

The codes shown in the following table which correspond to errors that occur are recorded in addresses 10, 14, and 18.

Code	Type of Emergency
00	No error
10	Loading motor time-out during load
11	Loading motor time-out during unload
20	T reel emergency (reel slack) during unloading
21	S reel emergency (reel slack) during unloading
22	T reel emergency
23	S reel emergency
30	FG emergency at the start up of the capstan
31	FG emergency during the normal rotation of the capstan
40	FG emergency at the start up of the drum
41	PG emergency at the start up of the drum
42	FG emergency during the normal rotation of the drum
43	PG emergency during the normal rotation of the drum
44	Phase emergency during the normal rotation of the drum

2-2. MSW codes

- The lower parts of the data of addresses 12, 16 and 1A represent the MSW codes (mode switch, mechanism position) when errors occurs.
- The upper parts of the data of addresses 12, 16 and 1A represent, when the mechanism position is to be moved, the MSW codes at the start of movement (when moving the loading motor).
- The lower parts of the data of addresses 13, 17 and 1B represent the MSW codes of the desired movement when the mechanism position is to be moved.

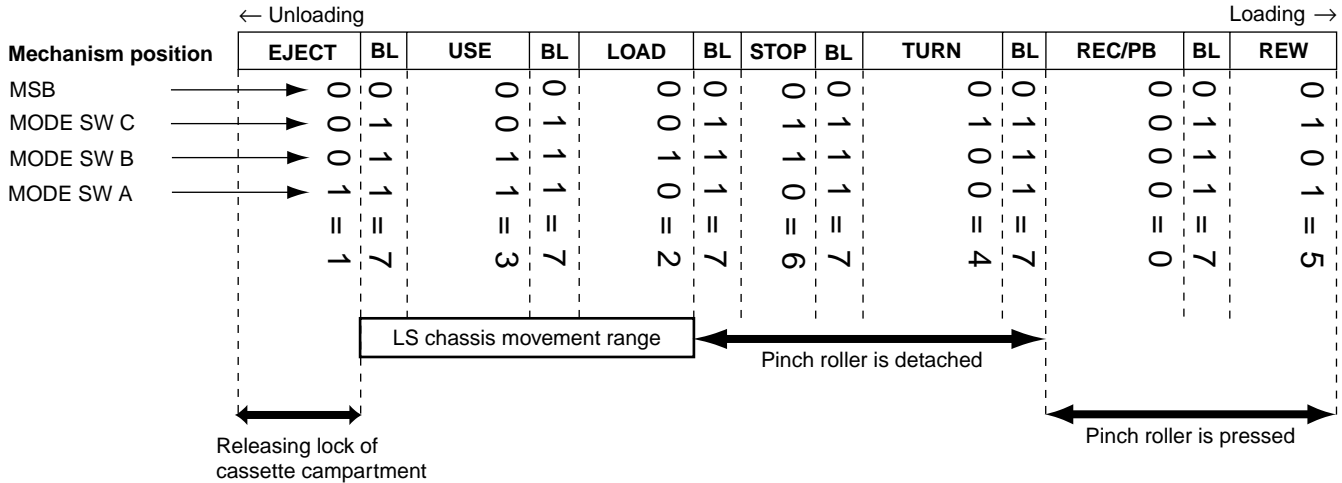

Mechanism Position	MSW Code	Contents
EJECT	1	Position at which the cassette compartment lock is released. The mechanism will not move any further in the unloading direction.
BL	7	BLANC code. Between two codes. The mechanism will not be stopped by this code while it is operating.
USE	3	EJECT completion position. When the cassette is ejected, the mechanism will stop at this position.
LOAD	2	Code during loading/unloading. Code that is used while the LS chassis is moving.
STOP	6	Normal stop position. The pinch roller separates, the tension regulator returns, and the brakes of both reels turn on.
TURN	4	Position at which is used when the pendulum gear swings from S to T or from T to S.
RECP/PB	0	PB, REC, CUE, REV, PAUSE, FF positions. The pinch roller is pressed and tension regulator is on.
REW	5	REW position. REW are carried at this position. The mechanism will not move any further in the loading direction.

3. Bit Value Discrimination

Bit values must be discriminated using the display data of the adjustment remote commander for the following items. Use the table below to discriminate if the bit value is "1" or "0".

Display on the adjustment remote commander

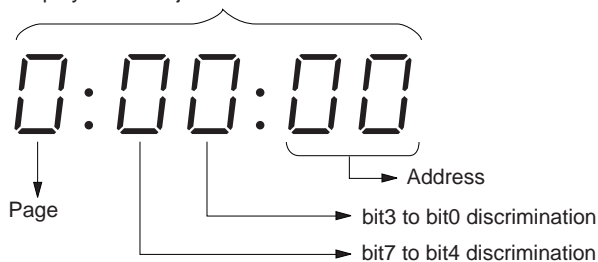

(Example) If the remote commander display is "8E", bit value from bit 7 to bit 4 can be discriminated from the column ㉠, and those from bit 3 to bit 0 from column ㉡.

Display on the adjustment remote commander	Bit values			
	bit3 or bit7	bit2 or bit6	bit1 or bit5	bit0 or bit4
0	0	0	0	0
1	0	0	0	1
2	0	0	1	0
3	0	0	1	1
4	0	1	0	0
5	0	1	0	1
6	0	1	1	0
7	0	1	1	1
㉠ 8	1	0	0	0
9	1	0	0	1
A (F)	1	0	1	0
B (b)	1	0	1	1
C (L)	1	1	0	0
D (d)	1	1	0	1
㉡ E (E)	1	1	1	0
F (F)	1	1	1	1

4. Switch check (1)

Page 2	Address 43
--------	------------

Bit	Function	When bit value = 1	When bit value = 0
0	POWER SW (VTR MODE SW) (SS-1000 block)	OFF	ON (PLAYER)
1	POWER SW (CAM MODE SW) (SS-1000 block)	OFF	ON (CAMERA)
2	START/STOP SW (SS-1000 block)	OFF	ON
3	EJECT SW (FK-1000 block)	OFF	ON
4	CC DOWN SW (Mechanism chassis)	OFF (UP)	ON (DOWN)
5			
6			
7			

Using method:

- 1) Select page: 2, address: 43.
- 2) By discriminating the bit value of display data, the state of the switch can be discriminated.

5. Switch check (2)

Page 2	Address 49
--------	------------

Bit	Function	When bit value = 1	When bit value = 0
6	A/V OUT jack (FP-257 flexible)	Used	Not used
7	S VIDEO jack (FP-257 flexible)	Not used	Used

Using method:

- 1) Select page: 2, address: 49.
- 2) By discriminating the bit value of display data, the state of the switch can be discriminated.

6. Switch check (3)

(TRV model: CCD-TRV49/TRV49E/TRV58/TRV58E/TRV59E/TRV68/TRV78/TRV78E/TRV88/TRV98/TRV98E)

Page 2	Address 45
--------	------------

Bit	Function	When bit value = 1	When bit value = 0
1	HEADPHONE jack (CF-1000 block)	Used	Not used

Using method:

- 1) Select page: 2, address: 45.
- 2) By discriminating the bit value of display data, the state of the switch can be discriminated.

7. Switch check (4)

Page 2	Address 60 to 65
--------	------------------

Using method:

- 1) Select page: 2, address: 60 to 65.
- 2) By discriminating the display data, the pressed key can be discriminated.

Address	Data							
	00 to 0C	0D to 24	25 to 3F	40 to 5D	5E to 81	82 to AA	AB to D7	D8 to FF
60 (KEY AD0) (IC4803 ㉓)	SUPER LASER LINK (FK-1000) *1	LIGHT (FK-1000) *2	STOP (FK-1000)	FF (FK-1000)				No key input
61 (KEY AD1) (IC4803 ㉔)			PAUSE (FK-1000)	REW (FK-1000)	PLAY (FK-1000)			No key input
62 (KEY AD2) (IC4803 ㉕)	MENU (CF-077 S002) (CF-1000) *4	EXPOSURE (CF-077 S004) (CF-1000) *4	MENU EXECUTE (CF-077 S006) (CF-1000) *4	TITLE (CF-077 S007) (CF-1000) *4	VOLUME + (CF-1000) *4	VOLUME - (CF-1000) *4	BACKLIGHT (CF-077 S009) (CF-1000) *4	No key input
63 (KEY AD3) (IC4803 ㉖)		DATA (CF-077 S005) (CF-1000) *4				COUNTER RESET (CF-077 S008) (CF-1000) *4	PANEL CLOSE (S902) *3	PANEL OPEN (S902) *3
64 (KEY AD4) (IC4803 ㉗)	TIME (CF-077 S003) (CF-1000) *4		END SEARCH (CF-1000) *4	DISPLAY (CF-1000) *4		FADER (CF-077 S011) (CF-1000) *4	FOCUS (CF-077 S010) (CF-1000) *4	No key input
65 (KEY AD5) (IC4803 ㉘)	PANEL REVERSE (PR-10500) *3							PANEL NORMAL (PR-10500) *3

*1: LASER LINK model (CCD-TRV98)

*2: Video light model (CCD-TR618/TR618E/TR718E/TR728E/TR818/TRV49/TRV49E/TRV58/TRV58E/TRV59E/TRV68/TRV78/
TRV78E/TRV88/TRV98/TRV98E)

*3: TRV model (CCD-TRV49/TRV49E/TRV58/TRV58E/TRV59E/TRV68/TRV78/TRV78E/TRV88/TRV98/TRV98E)

*4: CF-1000 block: TRV model

CF-077 board: TR model

8. Record of Use check

Note: When replacing the drum assembly, initialize the data of address: A2 to A4.

When replacing the video light, initialize the data of address: E0 to E2.

Page 2	Address A2 to AA, E0 to E2
--------	----------------------------

Address	Function	Remarks
A2	Drum rotation	Hour (H) 1000th place digit and 100th place digit of counted time (decimal digit)
A3	counted time (BCD code)	Hour (L) 10th place digit and 1st place digit of counted time (decimal digit)
A4		Minutes
A5	User initial power	Year
A6	on date	Month
A7	(BCD code)	Day
A8	Final condensation	Year
A9	occurrence date	Month
AA	(BCD code)	Day
E0	Video light	Hour (H) 1000th place digit and 100th place digit of counted time (decimal digit)
E1	counted time	Hour (L) 10th place digit and 1st place digit of counted time (decimal digit)
E2	(BCD code)	Minutes

Using method:

- 1) The record of use data is displayed at page: 2, addresses: A2 to AA and E0 to E2.

Note: This data will be erased (reset) when the cabinet (R) assembly (VC-251 board CN709 (24P)) is removed.

Initializing method:

- 1) Using the adjustment remote commander, select the object address and set data: 00.

9. Record of Self-diagnosis check

Page 2	Address B0 to C6
--------	------------------

Address	Self-diagnosis code
B0	“Repaired by” code (Occurred 1st time) *1
B1	“Block function” code (Occurred 1st time)
B2	“Detailed” code (Occurred 1st time)
B4	“Repaired by” code (Occurred 2nd time) *1
B5	“Block function” code (Occurred 2nd time)
B6	“Detailed” code (Occurred 2nd time)
B8	“Repaired by” code (Occurred 3rd time) *1
B9	“Block function” code (Occurred 3rd time)
BA	“Detailed” code (Occurred 3rd time)
BC	“Repaired by” code (Occurred 4th time) *1
BD	“Block function” code (Occurred 4th time)
BE	“Detailed” code (Occurred 4th time)
C0	“Repaired by” code (Occurred 5th time) *1
C1	“Block function” code (Occurred 5th time)
C2	“Detailed” code (Occurred 5th time)
C4	“Repaired by” code (Occurred the last time) *1
C5	“Block function” code (Occurred the last time)
C6	“Detailed” code (Occurred the last time)

*1 : “01”→“C”, “03”→“E”

Using method:

- 1) The past self-diagnosis codes are displayed at page: 2, addresses: BC to C6. Refer to “SELF-DIAGNOSIS FUNCTION” for detail of the self-diagnosis code.

Note: This data will be erased (reset) when the cabinet (R) assembly (VC-251 board CN709 (24P)) is removed.

CCD-TR618/TR618E/TR718E/TR728E/TR818/TRV49/TRV49E/TRV58/ TRV58E/TRV59E/TRV68/TRV78/TRV78E/TRV88/TRV98/TRV98E

SECTION 6 REPAIR PARTS LIST

6-1. EXPLODED VIEWS

NOTE:

- -XX, -X mean standardized parts, so they may have some differences from the original one.
- Items marked “*” are not stocked since they are seldom required for routine service. Some delay should be anticipated when ordering these items.
- The mechanical parts with no reference number in the exploded views are not supplied.

- Abbreviation
CND : Canadian model
HK : Hong Kong model
KR : Korea model
JE : Tourist model
AUS : Australian model
CN : Chinese model
BR : Brazilian model
AR : Argentina model

The components identified by mark Δ or dotted line with mark Δ are critical for safety. Replace only with part number specified.

Les composants identifiés par une marque Δ sont critiques pour la sécurité. Ne les remplacer que par une pièce portant le numéro spécifié.

6-1-1. OVERALL SECTION

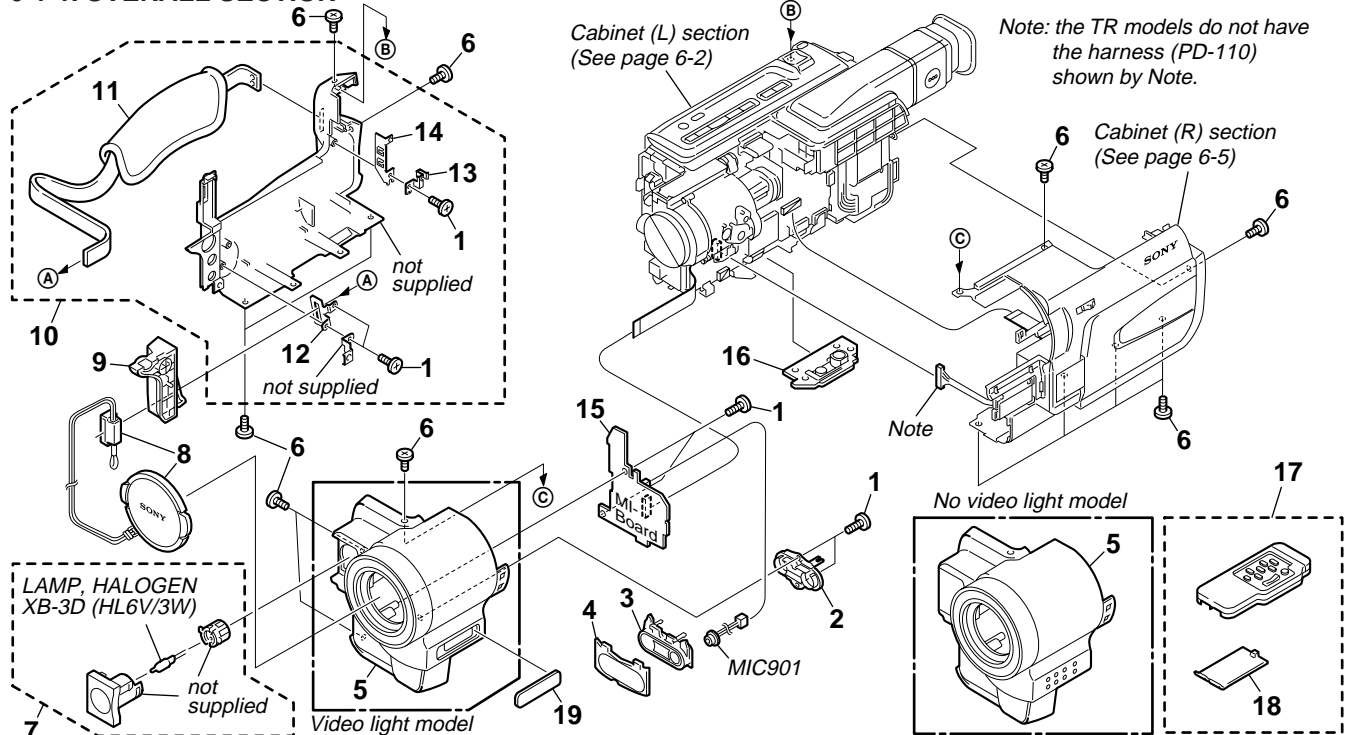

TR model : CCD-TR618/TR618E/TR718E/TR728E/TR818
 Video light model : CCD-TR618/TR618E/TR718E/TR728E/
 TRV49/TRV49E/TRV58/TRV58E/TRV59E/TRV68/TRV78/TRV78E/TRV88/TRV98/TRV98E
 No video light model : CCD-TR818

Ref. No.	Part No.	Description	Remarks	Ref. No.	Part No.	Description	Remarks
1	3-948-339-61	TAPPING		* 12	3-065-455-01	STOPPER (FRONT) (10), BELT	
2	3-065-468-01	RETAINER (REAR), MICROPHONE		* 13	3-065-457-01	PLATE REAR (10), L GROUND	
3	3-065-467-11	RETAINER (FRONT), MICROPHONE		14	3-058-622-01	STOPPER (REAR), BELT	
* 4	3-065-470-01	CUSHION (10), MICROPHONE		15	A-7074-659-A	MI-040 (L0) BOARD, COMPLETE	
5	X-3951-213-1	PANEL(10) ASSY, F (TRV88)				(TR618/TR618E/TR718E)	
5	X-3951-214-1	PANEL(10) ASSY, F (TR728E)		15	A-7074-661-A	MI-040 (MM0) BOARD, COMPLETE (TR818)	
5	X-3951-215-1	PANEL(10) ASSY, F (TR818)		15	A-7074-665-A	MI-041 (MMI) BOARD, COMPLETE (TRV98)	
5	X-3951-216-1	PANEL(10) ASSY, F (TRV98)		15	A-7074-682-A	MI-041 (MM) BOARD, COMPLETE	
5	X-3951-217-1	PANEL(10) ASSY, F (TR618/TR618E)				(TRV78/TRV78E/TRV98E)	
5	X-3951-218-1	PANEL(10) ASSY, F (TRV59E)		15	A-7074-683-A	MI-040 (0) BOARD, COMPLETE (TR728E)	
5	X-3951-219-1	PANEL(10) ASSY, F (TR718E)		15	A-7074-700-A	MI-041 (ML) BOARD, COMPLETE	
5	X-3951-221-1	PANEL(10) ASSY, F (TRV68)				(TRV58/TRV58E)	
5	X-3951-368-1	PANEL(10) ASSY, F (TRV78/TRV78E/TRV98E)		15	A-7074-707-A	MI-041 (MML) BOARD, COMPLETE	
5	X-3951-383-1	PANEL(10) ASSY, F (TRV49/TRV49E)				(TRV68/TRV88)	
5	X-3951-384-1	PANEL(10) ASSY, F (TRV58/TRV58E)		15	A-7074-719-A	MI-041 (M) BOARD, COMPLETE	
6	3-067-347-01	MI SCREW M2 (H)				(TRV49/TRV49E/TRV59E)	
7	1-518-723-21	LIGHT, VIDEO		16	3-987-717-01	SCREW, TRIPOD	
	(TR618/TR618E/TR718E/TR728E/TRV49/TRV49E/TRV58/TRV58E/ TRV59E/TRV68/TRV78/TRV78E/TRV88/TRV98/TRV98E)			17	1-467-574-21	REMOTE COMMANDER (RMT-708)	
8	X-3949-376-1	CAP(N) ASSY, LENS				(TR728E/TRV49/TRV49E/TRV59E/TRV78/TRV78E/TRV98/TRV98E)	
9	3-065-433-01	COVER(10), JACK		18	3-958-131-01	LID, BATTERY CASE (FOR RMT-708)	
10	X-3951-193-1	CABINET L (10) ASSY		19	3-065-464-11	WINDOW (12), LCD	
						(TRV49/TRV49E/TRV58/TRV58E/TRV59E/TRV68/ TRV78/TRV78E/TRV88/TRV98/TRV98E)	
11	3-052-815-01	BELT(ES), GRIP		MIC901	1-542-312-11	MICROPHONE	

6-1-2. CABINET (L) SECTION

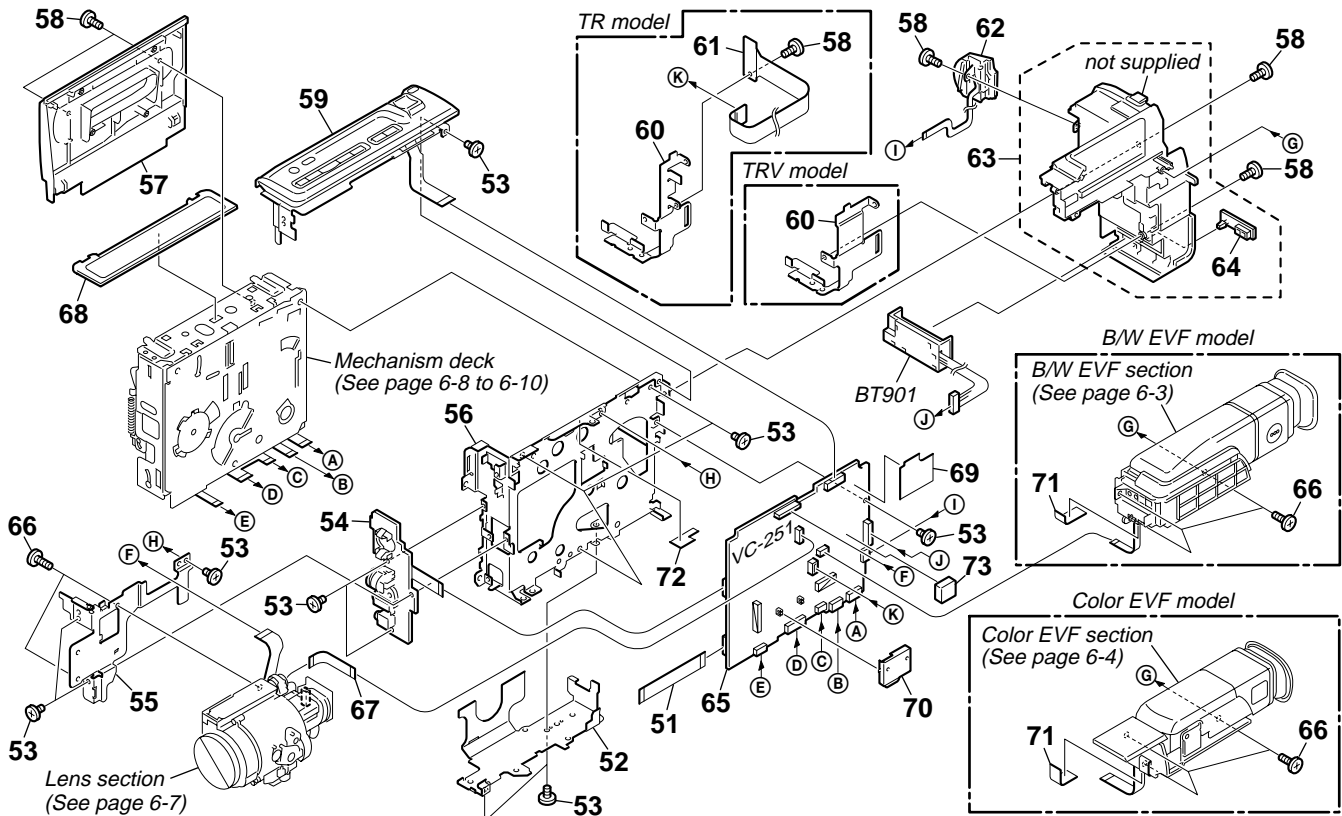

TR model : CCD-TR618/TR618E/TR718E/TR728E/TR818

TRV model : CCD-TRV49/TRV49E/TRV58/TRV58E/TRV59E/TRV68/TRV78/TRV78E/TRV88/TRV98/TRV98E

B/W EVF model : CCD-TR618/TR618E/TR718E/TR728E/

TRV49/TRV49E/TRV58/TRV58E/TRV59E/TRV68/TRV78/TRV78E/TRV88/TRV98/TRV98E

Color EVF model : CCD-TR818

Ref. No.	Part No.	Description	Remarks	Ref. No.	Part No.	Description	Remarks
51	1-680-203-11	FP-263 FLEXIBLE BOARD		63	X-3951-471-1	PANEL (B)(12) ASSY, BATTERY (TRV58:BR/TRV98:BR)	
* 52	3-065-428-01	FRAME B (10), MD		64	3-987-656-01	LID,JACK	
53	3-968-729-51	SCREW (M2), LOCK ACE, P2		65	A-7096-402-A	VC-251 (N-B) BOARD, COMPLETE (SERVICE) (TR618)	
54	1-680-198-11	FP-257 FLEXIBLE BOARD		65	A-7096-403-A	VC-251 (N-C) BOARD, COMPLETE (SERVICE) (TR818)	
* 55	3-065-429-01	FRAME (10), LENS		65	A-7096-404-A	VC-251 (P-B) BOARD, COMPLETE (SERVICE) (TR618E/TR718E/TR728E)	
* 56	3-065-427-01	FRAME A (10), MD		65	A-7096-405-A	VC-251 (N-VMMB) BOARD, COMPLETE (SERVICE)(TRV68/TRV78/TRV88/TRV98)	
57	X-3951-228-1	LID(10) ASSY, CASSETTE		65	A-7096-406-A	VC-251 (P-VMMB) BOARD, COMPLETE (SERVICE)(TRV78E/TRV98E)	
58	3-067-347-01	MI SCREW M2 (H)		65	A-7096-409-A	VC-251 (N-VB) BOARD, COMPLETE (SERVICE) (TRV49/TRV58)	
59	1-476-424-11	SWITCH BLOCK, CONTROL (FK-1000) (TR618/TR618E/TR718E/TR728E/TRV49/TRV49E/TRV58/ TRV58E/TRV59E/TRV68/TRV78/TRV78E/TRV88/TRV98E)		65	A-7096-456-A	VC-251 (P-VB) BOARD, COMPLETE (SERVICE) (TRV49E/TRV58E/TRV59E)	
59	1-476-424-21	SWITCH BLOCK, CONTROL (FK-1000)(TR818)		66	3-948-339-61	TAPPING	
59	1-476-424-51	SWITCH BLOCK, CONTROL (FK-1000)(TRV98)		67	1-680-200-11	FP-259 FLEXIBLE BOARD	
60	3-065-421-01	SHEET METAL (LOWER)(12), STRAP (TRV49/TRV49E/TRV58/TRV58E/TRV59E/TRV68/ TRV78/TRV78E/TRV88/TRV98/TRV98E)		68	X-3950-697-1	LID ASSY, LS	
60	3-065-422-01	SHEET METAL (LOWER)(10), STRAP (TR618/TR618E/TR718E/TR728E/TR818)		* 69	3-065-654-01	SHIELD (10), DD	
61	1-680-202-11	FP-262 FLEXIBLE BOARD (TR618/TR618E/TR718E/TR728E/TR818)		* 70	3-065-432-01	CASE (10), RP SHIELD	
62	1-476-423-11	SWITCH BLOCK, CONTROL (SS-1000)		71	3-941-343-21	TAPE(A)	
63	X-3951-196-1	PANEL (12) ASSY, BATTERY (TRV49/TRV49E/TRV58:US,CND,E,AR/TRV58E/TRV59E/TRV68/ TRV78/TRV78E/TRV88/TRV98:US,CND,E,HK,KR,JE/TRV98E)		72	3-067-254-01	SHEET (10), ABSORBING	
63	X-3951-198-1	PANEL (10) ASSY, BATTERY (TR618/TR618E/TR718E/TR728E/TR818:US,CND,E,AR)		* 73	3-062-053-01	SPACER, PC	
63	X-3951-470-1	PANEL (B)(10) ASSY, BATTERY (TR818:BR)		BT901	1-694-384-11	TERMINAL BOARD, BATTERY	

6-1-3. B/W EVF SECTION (TR618/TR618E/TR718E/TR728E/TRV49/TRV49E/TRV58/TRV58E/TRV59E/TRV68/TRV78/TRV78E/TRV88/TRV98/TRV98E)

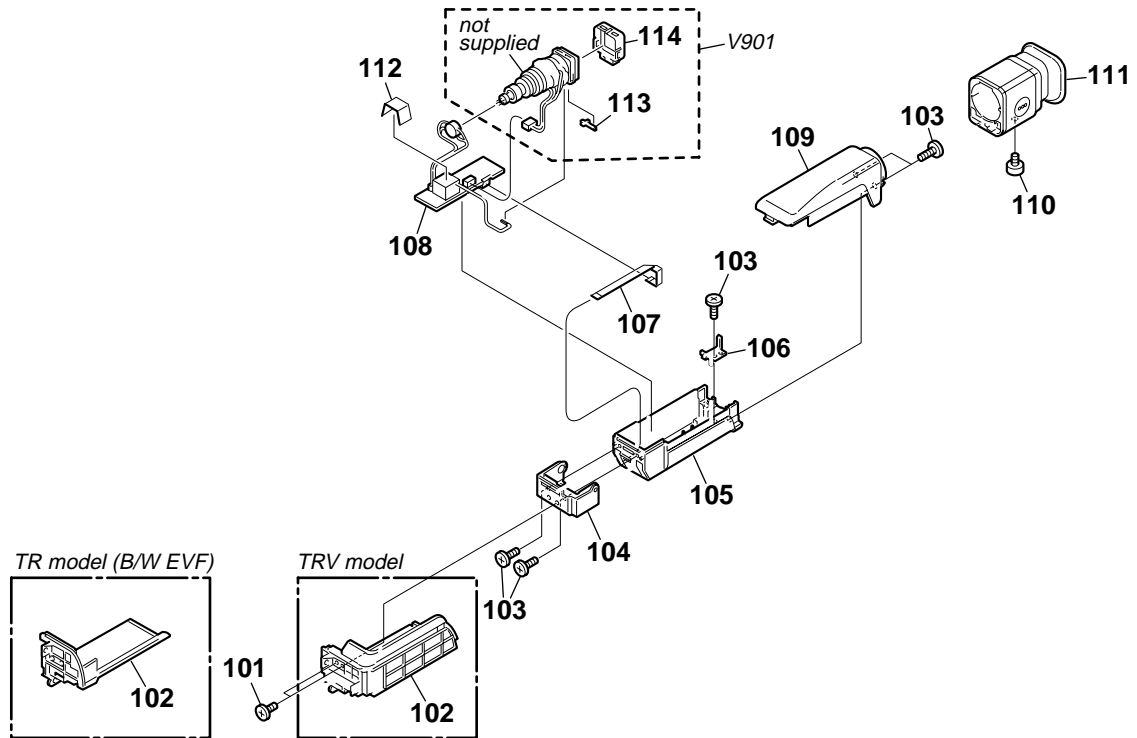

TR model (B/W EVF) : CCD-TR618/TR618E/TR718E/TR728E

TRV model : CCD-TRV49/TRV49E/TRV58/TRV58E/TRV59E/TRV68/TRV78/TRV78E/TRV88/TRV98/TRV98E

Ref. No.	Part No.	Description	Remarks	Ref. No.	Part No.	Description	Remarks
101	3-061-794-01	SCREW, LOOSE STOPPER		108	A-7073-855-A	VF-129 (P) BOARD, COMPLETE (TR618E/TR718E/TR728E/TRV49E/ TRV58E/TRV59E/TRV78E/TRV98E)	
102	3-065-481-01	BASE B (12), VF (TRV49/TRV49E/TRV58/TRV58E/TRV59E/TRV68/ TRV78/TRV78E/TRV88/TRV98/TRV98E)		109	X-3951-202-1	CABINET UPPER B (12) ASSY, EVF (TRV49/TRV49E/TRV58/TRV58E/TRV59E/TRV68/ TRV78/TRV78E/TRV88/TRV98/TRV98E)	
102	3-065-482-01	BASE B (10), VF (TR618/TR618E/TR718E/TR728E)		109	X-3951-203-1	CABINET UPPER B (10) ASSY, EVF (TR618/TR618E/TR718E/TR728E)	
103	3-948-339-81	TAPPING		110	3-975-898-01	SCREW (T), F LOCK	
104	X-3950-230-1	HINGE ASSY, VF		111	X-3949-329-1	FINDER (S) ASSY	
105	3-058-644-11	CABINET (LOWER) (B) (100), EVF (TR618/TR618E/TR718E/TR728E)		112	3-941-343-21	TAPE (A)	
105	3-065-480-01	CABINET LOWER B (12), EVF (TRV49/TRV49E/TRV58/TRV58E/TRV59E/TRV68/ TRV78/TRV78E/TRV88/TRV98/TRV98E)		113	3-709-272-01	COVER, HIGH VOLTAGE	
106	3-053-681-01	TALLY, EVF		114	3-709-273-01	MASK, CRT	
107	1-792-454-11	CABLE, FLEXIBLE FLAT (FFC-289)		△ V901	1-452-673-61	CRT ASSY (M01KXX90WB)	
108	A-7073-838-A	VF-129 (N) BOARD, COMPLETE (TR618/TRV49/TRV58/TRV68/TRV78/TRV88/TRV98)					

<p>Note : The components identified by mark △ or dotted line with mark △ are critical for safety. Replace only with part number specified.</p>	<p>Note : Les composants identifiés par une marque △ sont critiques pour la sécurité. Ne les remplacer que par une pièce portant le numéro spécifié.</p>
---	---

6-1-4. COLOR EVF SECTION (TR818)

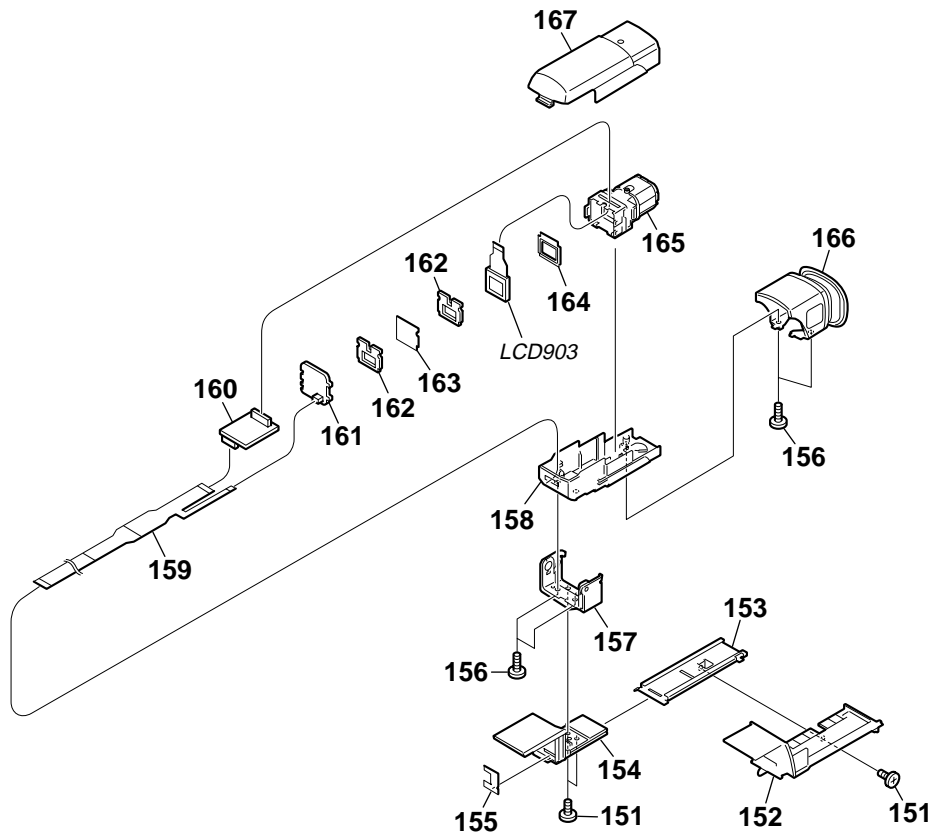

Ref. No.	Part No.	Description	Remarks	Ref. No.	Part No.	Description	Remarks
151	3-067-347-01	MI SCREW M2 (H)		160	A-7074-193-A	VF-141 BOARD, COMPLETE	
152	3-065-484-01	BASE C (10), VF		161	A-7074-192-A	LB-62 BOARD, COMPLETE	
153	3-065-483-01	PLATE (10), SLIDE FIXED		* 162	3-058-234-02	CUSHION (2) (97), LCD	
154	X-3951-205-1	BASE (10) ASSY, SLIDE		163	3-058-233-01	ILLUMINATOR (97), BL	
* 155	3-058-640-01	RETAINER (100), HARNESS		* 164	3-058-232-01	CUSHION (1) (97), LCD	
156	3-948-339-81	TAPPING		165	X-3950-101-1	LENS (C) (97) ASSY, VF	
157	X-3950-230-1	HINGE ASSY, VF		166	X-3950-227-1	CABINET (REAR) (100) ASSY, EVF	
158	X-3951-204-1	CABINET LOWER C (10) ASSY, EVF		167	3-058-638-11	CABINET (UPPER) (100), EVF	
159	1-676-299-11	FP-151 FLEXIBLE BOARD		LCD903	8-753-028-47	LCX032AN-J	

6-1-5. CABINET (R) SECTION

TRV model

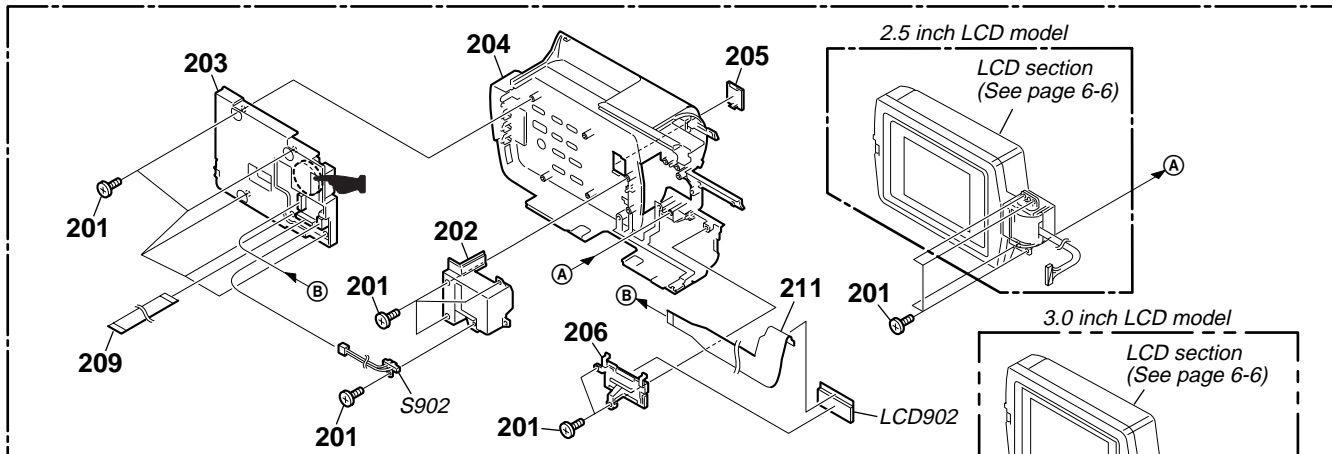

TR model

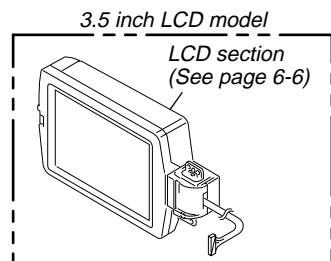
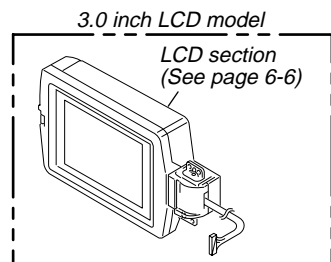
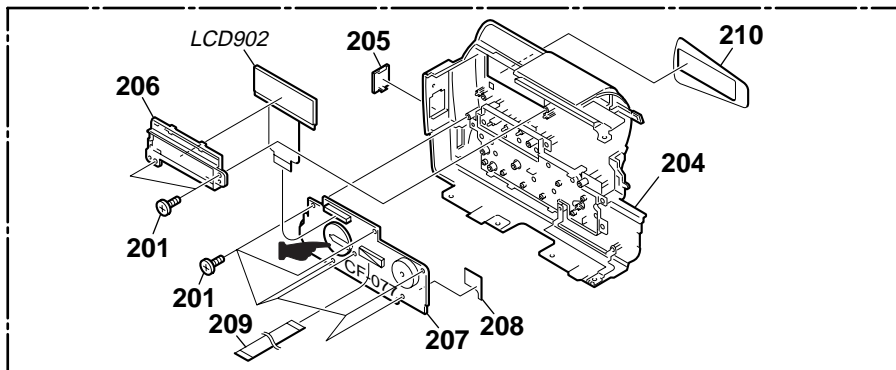

 : BT001(Lithium battery) CF board on the mount position. (See page 4-36/TR model)
 [In the TRV model, the printed wiring board of the control switch block (CF-1000) on which lithium battery is mounted, is not shown.]

- TR model : CCD-TR618/TR618E/TR718E/TR728E/TR818
 TRV model : CCD-TRV49/TRV49E/TRV58/TRV58E/TRV59E/TRV68/TRV78/TRV78E/TRV88/TRV98/TRV98E
 2.5 inch LCD model : CCD-TRV49/TRV49E/TRV58/TRV58E/TRV59E/TRV68/TRV78/TRV78E
 3.0 inch LCD model : CCD-TRV88
 3.5 inch LCD model : CCD-TRV98/TRV98E

Ref. No.	Part No.	Description	Remarks	Ref. No.	Part No.	Description	Remarks
201	3-948-339-61	TAPPING		* 208	3-065-453-01	SHEET (10), MUFFLE	
202	3-065-436-01	BLIND (12), HINGE (TRV49/TRV49E/TRV58/TRV58E/TRV59E/TRV68/ TRV78/TRV78E/TRV88/TRV98/TRV98E)		209	1-757-397-21	CABLE, FLEXIBLE FLAT (FFC-295)	
203	1-476-425-11	SWITCH BLOCK, CONTROL (CF-1000) (TRV49/TRV49E/TRV58/TRV58E/TRV59E/TRV68/ TRV78/TRV78E/TRV88/TRV98/TRV98E)		210	3-065-434-01	WINDOW (10), LCD (TR818)	
204	X-3951-224-1	CABINET R (12) ASSY (TRV49/TRV49E/TRV58/TRV58E/TRV59E/TRV68/ TRV78/TRV78E/TRV88/TRV98/TRV98E)		210	3-065-434-11	WINDOW (10), LCD (TR728E)	
204	X-3951-226-1	CABINET R (10) ASSY (TR618/TR618E/TR718E/TR728E/TR818)		210	3-065-434-21	WINDOW (10), LCD (TR618)	
205	3-059-539-11	LID(103P), CPC		210	3-065-434-31	WINDOW (10), LCD (TR618E)	
206	3-065-451-01	HOLDER (12), LCD (TRV49/TRV49E/TRV58/TRV58E/TRV59E/TRV68/ TRV78/TRV78E/TRV88/TRV98/TRV98E)		210	3-065-434-41	WINDOW (10), LCD (TR718E)	
206	3-065-452-01	HOLDER (10), LCD (TR618/TR618E/TR718E/TR728E/TR818)		211	1-680-201-11	FP-260 FLEXIBLE BOARD (TRV49/TRV49E/TRV58/TRV58E/TRV59E/TRV68/ TRV78/TRV78E/TRV88/TRV98/TRV98E)	
207	A-7074-663-A	CF-077 BOARD, COMPLETE (TR618/TR618E/TR718E/TR728E/TR818)		LCD902	1-803-844-91	DISPLAY PANEL, LIQUID CRYSTAL (TR618/TR618E/TR718E/TR728E/TR818)	
				LCD902	1-804-255-11	DISPLAY PANEL, LIQUID CRYSTAL (TRV49/TRV49E/TRV58/TRV58E/TRV59E/TRV68/ TRV78/TRV78E/TRV88/TRV98/TRV98E)	
				S902	1-771-848-11	SWITCH, PUSH (TRV49/TRV49E/TRV58/TRV58E/TRV59E/TRV68/ TRV78/TRV78E/TRV88/TRV98/TRV98E)	

6-1-6. LCD SECTION (TRV MODEL)
(TRV49/TRV49E/TRV58/TRV58E/TRV59E/TRV68/TRV78/TRV78E/TRV88/TRV98/TRV98E)

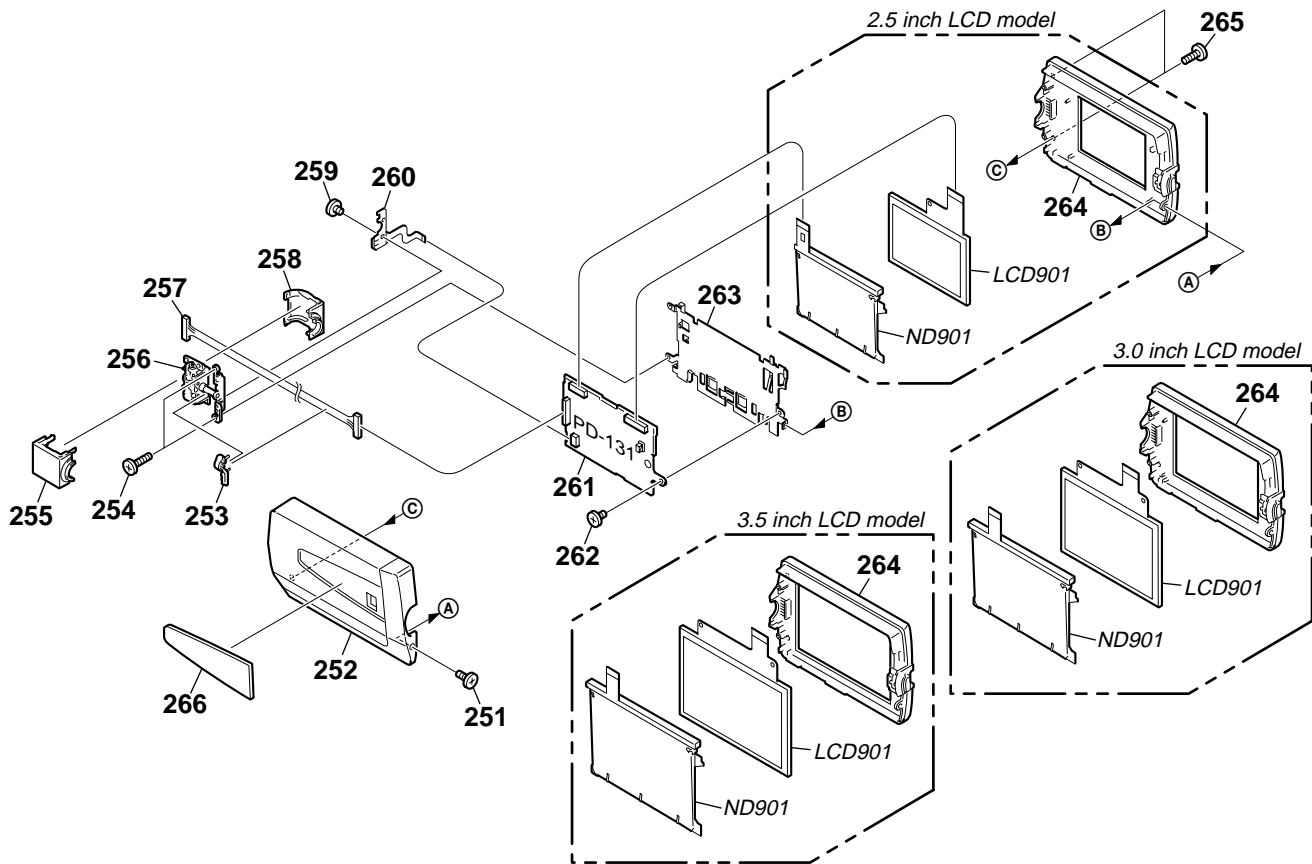

2.5 inch LCD model :CCD-TRV49/TRV49E/TRV58/TRV58E/TRV59E/TRV68/TRV78/TRV78E

3.0 inch LCD model :CCD-TRV88

3.5 inch LCD model :CCD-TRV98/TRV98E

Ref. No.	Part No.	Description	Remarks	Ref. No.	Part No.	Description	Remarks
251	3-067-347-01	MI SCREW M2 (H)		266	3-065-435-01	PLATE (12), PANEL ORNAMENTAL (TRV98)	
252	3-065-474-11	CABINET C (12), P		266	3-065-435-21	PLATE (12), PANEL ORNAMENTAL (TRV88)	
* 253	3-058-672-01	CLAMP, HARNESS		266	3-065-435-31	PLATE (12), PANEL ORNAMENTAL (TRV78)	
254	3-948-339-31	SCREW, TAPPING		266	3-065-435-41	PLATE (12), PANEL ORNAMENTAL (TRV59E)	
255	3-065-477-11	COVER C (12), HINGE		266	3-065-435-51	PLATE (12), PANEL ORNAMENTAL (TRV68)	
256	X-3951-206-1	HINGE (12) ASSY		266	3-065-435-61	PLATE (12), PANEL ORNAMENTAL (TRV98E)	
257	1-960-975-11	HARNESS (PD-110)		266	3-065-435-81	PLATE (12), PANEL ORNAMENTAL (TRV78E)	
258	3-065-478-01	COVER M (12), HINGE		266	3-065-529-21	PLATE (12), PANEL ORNAMENTAL (TRV58)	
259	4-974-725-01	SCREW (M1.7X2.5), P		266	3-065-529-31	PLATE (12), PANEL ORNAMENTAL (TRV49)	
260	1-418-802-11	SWITCH BLOCK, CONTROL (PR-10000)		266	3-065-529-41	PLATE (12), PANEL ORNAMENTAL (TRV58E)	
261	A-7074-667-A	PD-131 (S-3.5) BOARD, COMPLETE (TRV98/TRV98E)		266	3-065-529-51	PLATE (12), PANEL ORNAMENT (TRV49E)	
261	A-7074-680-A	PD-131 (S-2.5) BOARD, COMPLETE (TRV49/TRV49E/TRV58/TRV58E/TRV59E/TRV68/TRV78/TRV78E)		LCD901	1-803-852-31	INDICATOR MODULE LIQUID CRYSTAL (TRV49/TRV49E/TRV58/TRV58E/TRV59E/TRV68/TRV78/TRV78E)	
261	A-7074-701-A	PD-131 (S-3.0) BOARD, COMPLETE (TRV88)		LCD901	1-803-854-21	INDICATOR MODULE LIQUID CRYSTAL (TRV88)	
262	3-968-729-51	SCREW (M2), LOCK ACE, P2		LCD901	1-803-855-21	INDICATOR MODULE LIQUID CRYSTAL (TRV98/TRV98E)	
263	3-065-475-01	FRAME (12), PANEL (TRV49/TRV49E/TRV58/TRV58E/TRV59E/TRV68/TRV78/TRV78E)		△ND901	1-517-752-41	TUBE, FLUORESCENT,COLD CATHODE (TRV49/TRV49E/TRV58/TRV58E/TRV59E/TRV68/TRV78/TRV78E)	
* 263	3-065-475-11	FRAME (12), PANEL (TRV88/TRV98/TRV98E)		△ND901	1-517-855-31	TUBE, FLUORESCENT,COLD CATHODE (TRV98/TRV98E)	
264	X-3951-199-1	CABINET M (12) ASSY, P (TRV49/TRV49E/TRV58/TRV58E/TRV59E/TRV68/TRV78/TRV78E)		△ND901	1-517-856-31	TUBE, FLUORESCENT,COLD CATHODE (TRV88)	
264	X-3951-200-1	CABINET M (12) ASSY, P (TRV98/TRV98E)					
264	X-3951-201-1	CABINET M (12) ASSY, P (TRV88)					
265	3-948-339-81	TAPPING					

<p>Note : The components identified by mark Δ or dotted line with mark Δ are critical for safety. Replace only with part number specified.</p>	<p>Note : Les composants identifiés par une marque Δ sont critiques pour la sécurité. Ne les remplacer que par une pièce portant le numéro spécifié.</p>
--	--

6-1-7. LENS SECTION

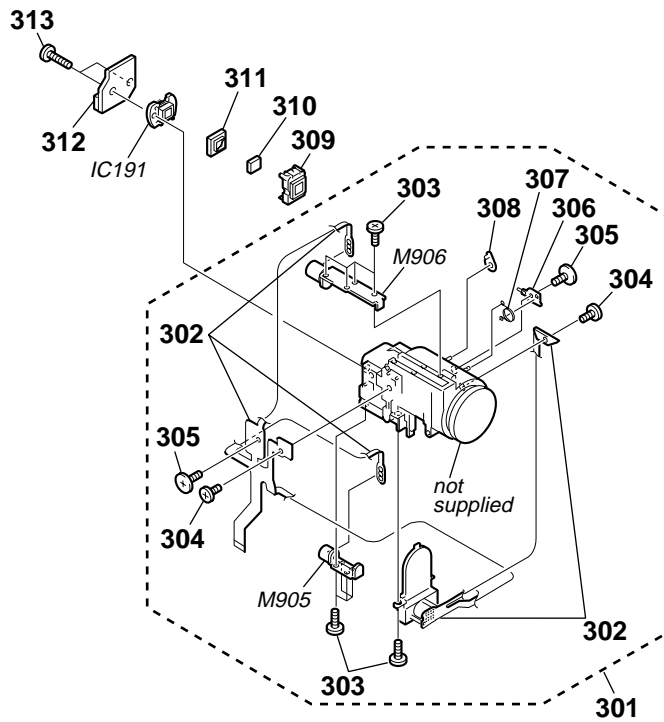

Be sure to read "Precautions upon replacing CCD imager" on page 4-8 when changing the CCD imager.

Ref. No.	Part No.	Description	Remarks	Ref. No.	Part No.	Description	Remarks
301	8-848-729-01	DEVICE, LENS LSV-630A		312	A-7074-658-A	CD-286 BOARD, COMPLETE (TR618/TR618E/TR718E/TR728E)	
302	X-3949-355-2	FLEXIBLE ASSY (630), IRIS		312	A-7074-662-A	CD-286 (MM) BOARD, COMPLETE (TR818)	
303	3-713-791-41	SCREW (M1.7X5), TAPPING, P2		312	A-7074-666-A	CD-281 (MM) BOARD, COMPLETE (TRV68/TRV78/TRV78E/TRV88/TRV98/TRV98E)	
304	3-713-791-51	SCREW (M1.7X3.5), TAPPING, P2		312	A-7074-698-A	CD-281 BOARD, COMPLETE (TRV49/TRV49E/TRV58/TRV58E/TRV59E)	
305	3-056-022-01	TAPPING (B1.7X3.5), HEAD		313	3-318-203-11	SCREW (B1.7X6), TAPPING	
306	3-053-827-01	LEVER, IR		IC191	A-7031-040-A	CCD BLOCK ASSY (TR618/TRV49/TRV58)	
307	3-053-800-01	SPRING, RETURN		IC191	A-7031-043-A	CCD BLOCK ASSY (TR618E/TR718E/TR728E/TRV49E/TRV58E/TRV59E)	
308	3-053-799-01	GEA, IR		IC191	A-7031-049-A	CCD BLOCK ASSY (TRV78E/TRV98E)	
309	3-978-981-11	ADAPTOR (FK), CCD FITTING		IC191	A-7031-207-A	CCD BLOCK ASSY (TR818/TRV68/TRV78/TRV88/TRV98)	
310	1-758-084-21	FILTER BLOCK, OPTICAL (TR618/TR618E/TR718E/TR728E/TRV49/ TRV49E/TRV58/TRV58E/TRV59E)		M905	1-763-262-11	MOTOR, STEPPING F630 (FOCUS)	
310	1-758-133-21	FILTER BLOCK, OPTICAL (TR818/TRV68/TRV78/TRV78E/TRV88/TRV98/TRV98E)		M906	1-763-046-21	MOTOR, STEPPING Z600 (ZOOM)	
311	3-953-817-01	RUBBER (F), SEAL (TR818/TRV68/TRV78/TRV78E/TRV88/TRV98/TRV98E)					
311	3-968-054-11	RUBBER (FM), SHIELD (TR618/TR618E/TR718E/TR728E/TRV49/ TRV49E/TRV58/TRV58E/TRV59E)					

6-1-8. CASSETTE COMPARTMENT ASSEMBLY

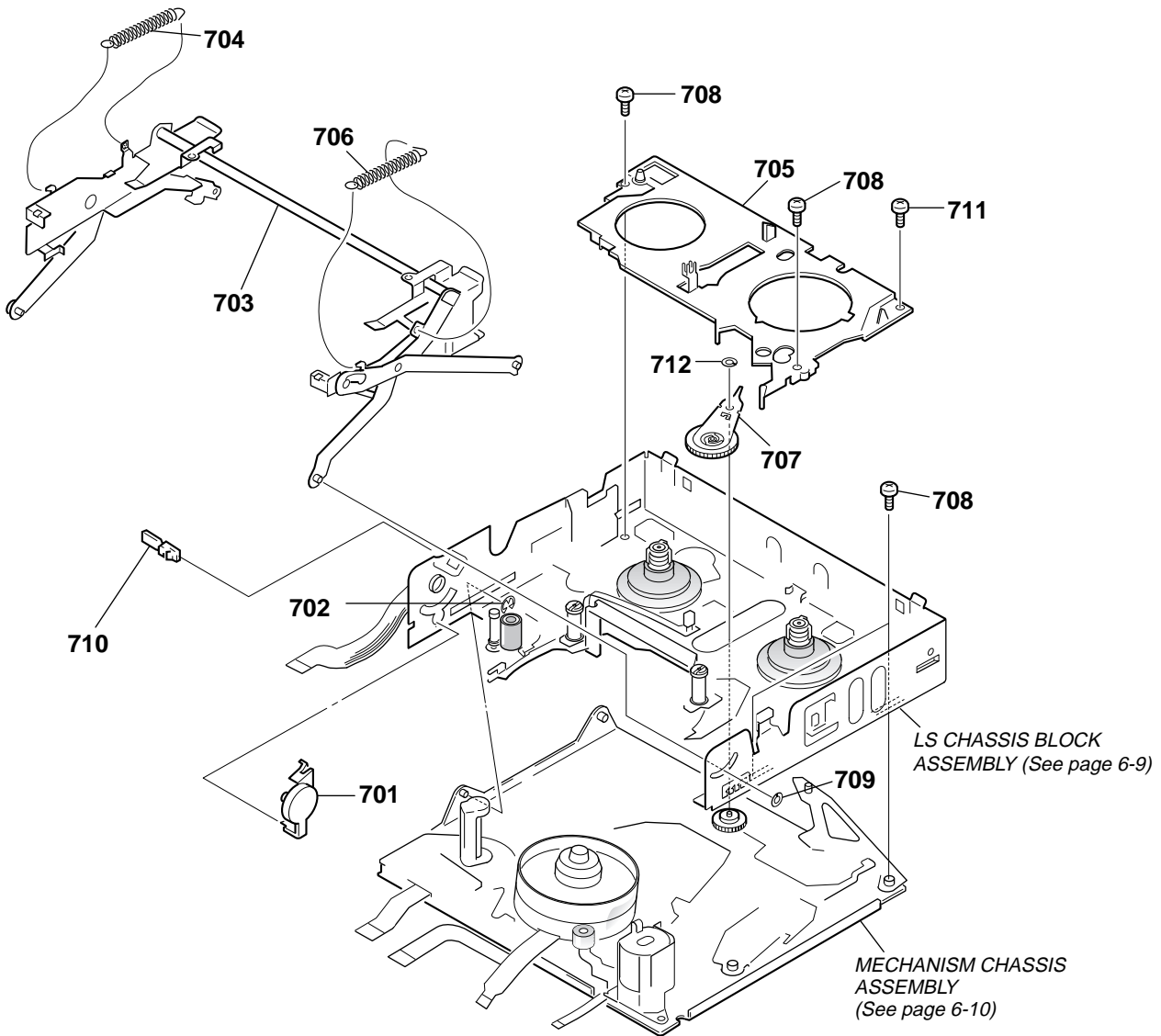

Ref. No.	Part No.	Description	Remarks	Ref. No.	Part No.	Description	Remarks
701	A-7040-421-A	DAMPER ASSY		707	X-3945-399-1	GEAR ASSY, GOOSENECK	
702	7-624-102-04	STOP RING 1.5, TYPE -E		708	3-947-503-01	SCREW (M1.4)	
703	X-3949-153-2	CASSETTE COMPARTMENT ASSY		709	3-979-686-01	WASHER, STOPPER	
704	3-965-587-03	SPRING(POWER TENSION),TENSION		710	3-971-076-01	FASTENER, D	
705	3-989-479-01	RETAINER (2), GOOSENECK		711	3-976-055-01	SCREW (M1.4X1)	
706	3-973-268-01	SPRING(POWER TENSION),TENSION		712	3-331-007-21	WASHER	

6-1-9. LS CHASSIS BLOCK ASSEMBLY

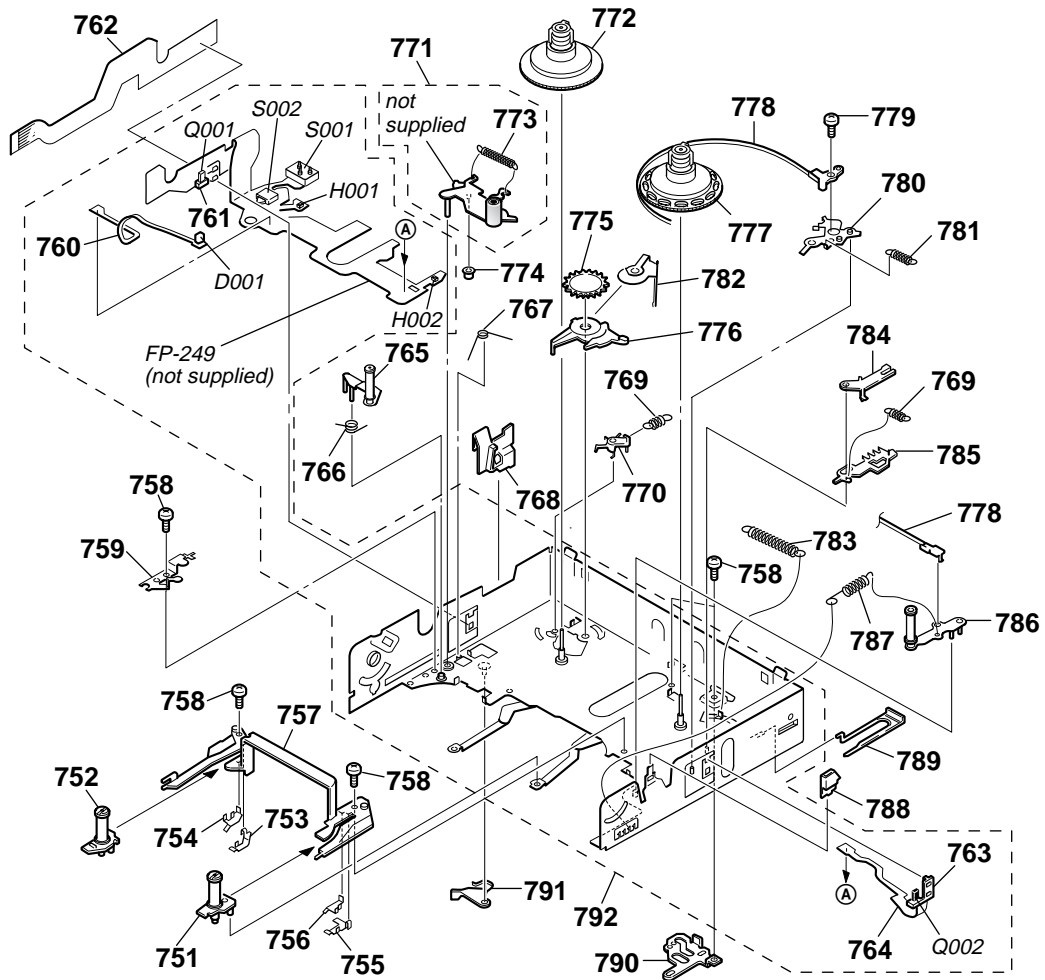

Ref. No.	Part No.	Description	Remarks	Ref. No.	Part No.	Description	Remarks
751	A-7040-419-A	BASE (S) BLOCK ASSY, GUIDE		776	3-965-565-01	CLAW, T SOFT	
752	A-7040-418-B	BASE (T) BLOCK ASSY, GUIDE		777	X-3945-397-4	DECK ASSY, REEL, S	
753	3-965-559-01	STOPPER (T)		778	X-3945-396-1	BAND ASSY, TENSION REGULATOR	
754	3-965-557-01	STOPPER (T), GB		779	3-945-756-01	SCREW (M1.4X3)	
755	3-965-558-01	STOPPER (S)		780	3-965-583-01	ARM, RVS	
756	3-965-556-01	STOPPER (S), GB		781	3-965-580-01	SPRING (ARM, RVS), TENSION	
757	3-965-553-01	RAIL, GUIDE		782	3-966-384-01	SPRING, T SOFT	
758	3-947-503-01	SCREW (M1.4)		783	3-965-578-01	SPRING, TENSION COIL	
759	3-965-573-01	RETAINER, TG4		784	3-965-560-01	RATCHET, S	
760	1-658-213-11	FP-355 FLEXIBLE BOARD		785	3-965-561-01	PLATE, RELEASE, S RATCHET	
761	3-965-552-01	HOLDER, SENSOR (T)		786	X-3945-395-1	ARM ASSY, TG1	
762	1-657-786-13	FP-221 FLEXIBLE PRINT BOARD		787	3-965-576-01	SPRING (TG1), TENSION	
763	3-965-551-01	HOLDER, SENSOR (S)		788	3-965-567-01	LID OPEN	
764	1-658-214-11	FP-356 FLEXIBLE BOARD		789	3-965-566-01	COVER, LS GUIDE	
765	A-7040-417-A	ARM BLOCK ASSY, TG4		* 790	3-965-577-01	PLATE, CAM, LS	
766	3-965-574-01	SPRING (RETURN, TG4), TORSION		791	3-965-569-01	ARM, EJ	
767	3-965-575-01	SPRING (PINCH), TORSION		792	A-7018-245-B	CHASSIS (S1) ASSY, LS	
768	3-965-568-11	GUIDE, LOCK		D001	8-719-988-42	DIODE GL453 (TAPE LED)	
769	3-965-562-01	SPRING (RATCHET), TENSION		H001	8-719-033-37	ELEMENT, HALL HW-105C (T REEL SENSOR)	
770	3-965-581-03	RATCHET, T		H002	8-719-033-37	ELEMENT, HALL HW-105C (S REEL SENSOR)	
771	X-3949-380-1	ARM ASSY (E), PINCH		Q001	8-729-907-25	PHOTO TRANSISTOR PT4850F (TAPE TOP)	
772	X-3945-398-6	DECK ASSY, REEL, T		Q002	8-729-907-25	PHOTO TRANSISTOR PT4850F (TAPE END)	
773	3-965-648-01	SPRING (PINCH), TENSION		S001	1-692-614-11	SWITCH, PUSH (3KEY) (Hi8 MP, ME/MP, REC PROOF)	
774	3-965-579-01	ROLLER, PINCH PRESS		S002	1-572-688-11	SWITCH, PUSH (1KEY) (C.C.LOCK)	
775	3-965-563-01	GEAR, T SOFT					

6-1-10. MECHANISM CHASSIS ASSEMBLY

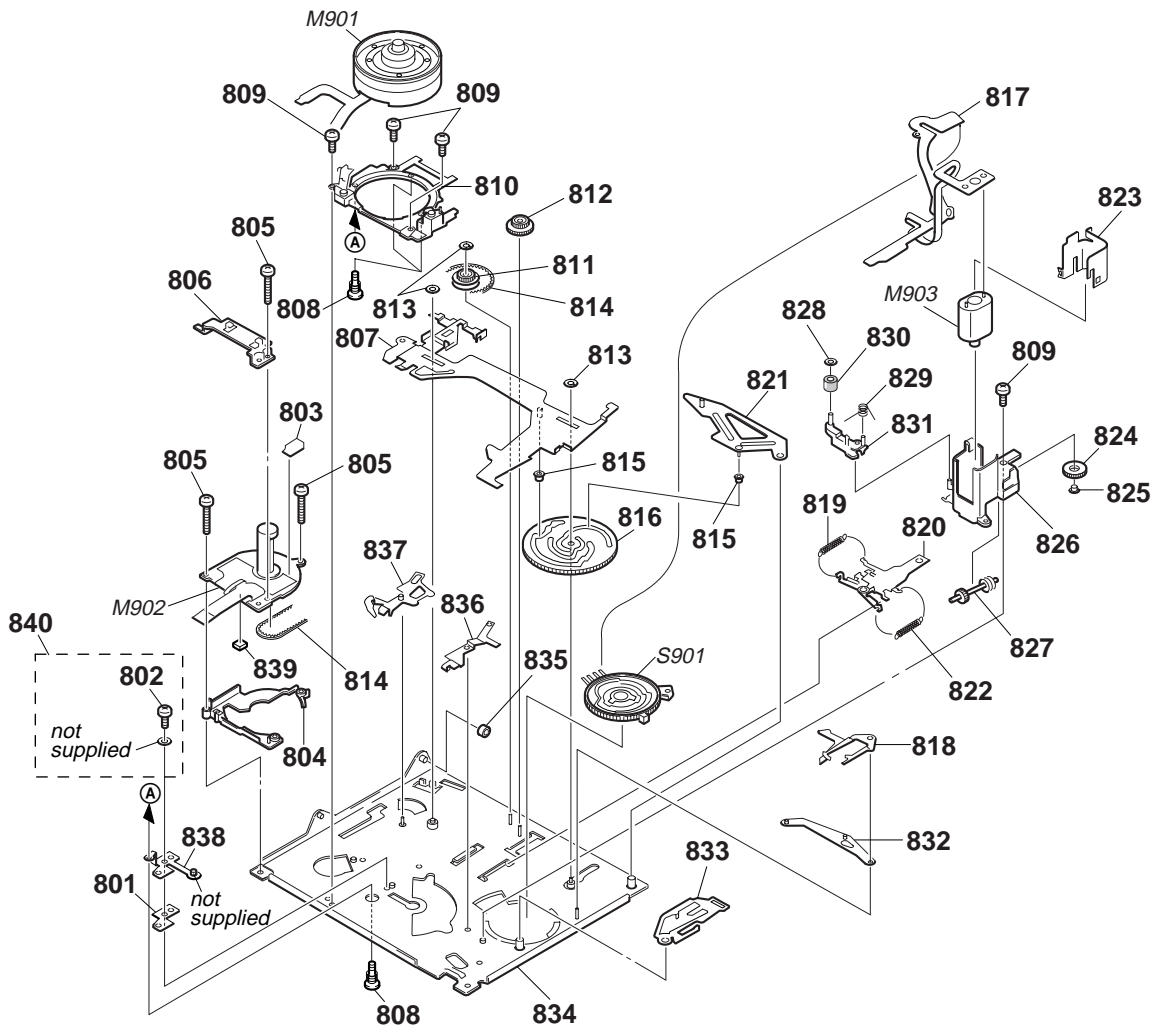

Ref. No.	Part No.	Description	Remarks	Ref. No.	Part No.	Description	Remarks
801	3-975-900-03	SPACER, GROUND		824	3-965-539-01	GEAR (A)	
802	3-965-550-02	SCREW (M1.7X1.6)		825	3-965-538-01	SLEEVE, MOTOR HOLDER	
803	1-657-785-11	FP-248 FLEXIBLE BOARD		826	3-965-540-01	HOLDER, MOTOR	
804	3-054-404-01	SPACER, CAPSTAN		827	3-965-541-01	SHAFT, WORM	
805	3-965-549-01	SCREW (M1.4 X 6.5)		828	3-321-393-01	WASHER, STOPPER	
806	3-966-349-01	HOLDER, FLEXIBLE		829	3-965-724-01	SPRING (RETURN, HC), TORSION	
807	3-971-644-02	SLIDER (2), M		830	A-7040-423-A	ROLLER BLOCK ASSY, HC	
808	X-3947-895-1	SCREW ASSY, DRUM ATTACHED		831	X-3945-407-1	ARM ASSY, HC ROLLER	
809	3-947-503-01	SCREW (M1.4)		832	3-965-531-01	ARM, GL	
810	A-7096-321-A	DRUM BASE BLOCK ASSY (BA)		833	3-965-530-01	PLATE (2), REGULATOR, TENSION	
811	3-965-527-01	GEAR, CHANGE		834	X-3949-589-3	CHASSIS ASSY, MECHANICAL	
812	3-965-544-01	GEAR, RELAY		835	3-965-526-02	ROLLER, LS GUIDE	
813	3-331-007-21	WASHER		836	3-965-547-01	ARM, HC DRIVING	
814	3-965-546-01	BELT, TIMING		837	3-965-534-01	PLATE, PRESS, PINCH	
815	3-965-533-01	ROLLER, LS		838	3-974-320-02	GROUND (IM), SHAFT	
816	3-965-528-01	GEAR, CAM		839	3-987-953-01	SPACER, RUBBER	
817	1-657-784-11	FP-220 FLEXIBLE BOARD		840	X-3947-398-1	SCREW ASSY, M1.7 PW	
818	3-965-529-01	PLATE, REGULATOR, TENSION		S901	1-762-436-15	SWITCH, ROTARY (ENCODER)	
819	3-965-536-01	SPRING (LIMITTER ARM T), COIL		M901	A-7048-953-A	DRUM BLOCK ASSY (DGH-0F0B-R) (NTSC)	
820	X-3945-388-1	SLIDER ASSY, GL		M901	A-7048-955-A	DRUM BLOCK ASSY (DGH-0F1B-R) (PAL)	
821	3-965-532-21	ARM, LS		M902	8-835-531-32	MOTOR, DC SCE-0601A/C-NP (CAPSTAN)	
822	3-965-535-01	SPRING (LIMITTER ARM S), COIL		M903	X-3945-401-1	MOTOR ASSY, DC (LOADING)	
823							

6-2. ELECTRICAL PARTS LIST

NOTE:

- Due to standardization, replacements in the parts list may be different from the parts specified in the diagrams or the components used on the set.
- -XX, -X mean standardized parts, so they may have some difference from the original one.
- Items marked “*” are not stocked since they are seldom required for routine service. Some delay should be anticipated when ordering these items.
- CAPACITORS:
uF: μF
COILS
uH: μH

- RESISTORS
All resistors are in ohms.
METAL: metal-film resistor
METAL OXIDE: Metal Oxide-film resistor
F: nonflammable
- SEMICONDUCTORS
In each case, u: μ, for example:
uA...: μA..., uPA..., μPA...,
uPB..., μPB..., uPC..., μPC...,
uPD..., μPD...
- Abbreviation
CND : Canadian model
HK : Hong Kong model
KR : Korea model
JE : Tourist model

When indicating parts by reference number, please include the board name.

The components identified by mark Δ or dotted line with mark Δ are critical for safety. Replace only with part number specified.

Les composants identifiés par une marque Δ sont critiques pour la sécurité. Ne les remplacer que par une pièce portant le numéro spécifié.

- AUS : Australian model
- CN : Chinese model
- BR : Brazilian model
- AR : Argentina model

Ref. No.	Part No.	Description	Remarks	Ref. No.	Part No.	Description	Remarks
	A-7074-658-A	CD-286 BOARD, COMPLETE (TR618/TR618E/TR718E/TR728E) *****		R198	1-216-864-91	SHORT 0 (TR818/TRV68/TRV78/TRV78E/TRV88/TRV98/TRV98E)	
	A-7074-662-A	CD-286 BOARD, COMPLETE (TR818) *****			A-7074-663-A	CF-077 BOARD, COMPLETE (TR618/TR618E/TR718E/TR728E/TR818) ***** (Ref.No.;1000 Series)	
	A-7074-666-A	CD-281 BOARD, COMPLETE (TRV68/TRV78/TRV78E/TRV88/TRV98/TRV98E) *****			< BATTERY >		
	A-7074-698-A	CD-281 BOARD, COMPLETE (TRV49/TRV49E/TRV58/TRV58E/TRV59E) ***** (Ref.No.;1000 Series) (IC191 is not included in this mounted board)		BT001	1-756-146-11	BATTERY, LITHIUM (SECONDARY) < BUZZER >	
		< CAPACITOR >		BZ001	1-529-107-11	BUZZER, PIEZOELECTRIC < CAPACITOR >	
C191	1-126-395-11	ELECT	22uF 20% 16V				
C195	1-164-156-11	CERAMIC CHIP	0.1uF 25V				
C196	1-128-994-21	ELECT CHIP	47uF 20% 10V				
		< CONNECTOR >		C001	1-125-777-11	CERAMIC CHIP 0.1uF 10% 10V < CONNECTOR >	
CN191	1-766-344-21	CONNECTOR, FFC/FPC 14P < IC >		CN001	1-815-031-11	CONNECTOR, FFC/FPC (ZIF) 24P	
				CN002	1-794-050-21	CONNECTOR, FFC/FPC (ZIF) 26P < IC >	
IC191	A-7031-040-A	CCD BLOCK ASSY (TR618/TRV49/TRV58)					
IC191	A-7031-043-A	CCD BLOCK ASSY (TR618E/TR718E/TR728E/TRV49E/TRV58E/TRV59E)		IC001	8-759-573-02	IC BU9735K-E2 < RESISTOR >	
IC191	A-7031-049-A	CCD BLOCK ASSY (TRV78E/TRV98E)					
IC191	A-7031-207-A	CCD BLOCK ASSY (TR818/TRV68/TRV78/TRV88/TRV98)		R005	1-216-822-11	METAL CHIP 1.2K 5% 1/16W	
		< COIL >		R006	1-216-822-11	METAL CHIP 1.2K 5% 1/16W	
L191	1-469-528-91	INDUCTOR 100uH < TRANSISTOR >		R010	1-216-855-11	METAL CHIP 680K 5% 1/16W	
				R011	1-216-823-11	METAL CHIP 1.5K 5% 1/16W	
Q191	8-729-117-73	TRANSISTOR 2SC4178-F13F14-T1 < RESISTOR >		R013	1-216-825-11	METAL CHIP 2.2K 5% 1/16W	
				R014	1-216-828-11	METAL CHIP 3.9K 5% 1/16W	
R191	1-216-797-11	METAL CHIP 10 5% 1/16W		R015	1-216-825-11	METAL CHIP 2.2K 5% 1/16W	
R192	1-216-864-91	SHORT 0		R016	1-216-834-11	METAL CHIP 12K 5% 1/16W	
R193	1-216-833-11	METAL CHIP 10K 5% 1/16W		R017	1-216-840-11	METAL CHIP 39K 5% 1/16W	
R195	1-216-864-91	SHORT 0		R018	1-216-838-11	METAL CHIP 27K 5% 1/16W	
R198	1-216-809-11	METAL CHIP 100 5% 1/16W (TR618/TR618E/TR718E/TR728E/TRV49/ TRV49E/TRV58/TRV58E/TRV59E)		R023	1-216-835-11	METAL CHIP 15K 5% 1/16W < SWITCH >	
				S001	1-771-138-82	SWITCH, KEY BOARD (RESET)	
				S002	1-771-138-82	SWITCH, KEY BOARD (MENU)	
				S003	1-771-138-82	SWITCH, KEY BOARD (TIME)	
				S004	1-771-138-82	SWITCH, KEY BOARD (EXPOSURE)	
				S005	1-771-138-82	SWITCH, KEY BOARD (DATE)	

Be sure to read "Precautions upon replacing CCD imager" on page 4-8 when changing the CCD imager.

CF-077

FP-249

FP-355

FP-356

LB-062

MI-040

MI-041

Ref. No.	Part No.	Description	Remarks
S006	1-771-025-41	SWITCH, ROTARY (ENCODER) (SEL/PUSH EXEC.)	
S007	1-771-138-82	SWITCH, KEY BOARD (TITLE)	
S008	1-771-138-82	SWITCH, KEY BOARD (COUNTER RESET)	
S009	1-771-138-82	SWITCH, KEY BOARD (BACK LIGHT)	
S010	1-771-138-82	SWITCH, KEY BOARD (FOCUS)	
S011	1-771-138-82	SWITCH, KEY BOARD (FADER)	
FP-249 BOARD, COMPLETE (Not supplied) ***** (Ref.No.;20000 Series)			
3-965-552-01	HOLDER (T), SENSOR	< HOLE ELEMENT >	
H001	8-719-033-37	ELEMENT, HALL HW-105C (T REEL)	
H002	8-719-033-37	ELEMENT, HALL HW-105C (S REEL)	
< TRANSISTOR >			
Q002	8-729-907-25	PHOTO TRANSISTOR PT4850F (TAPE END)	
< SWITCH >			
S001	1-692-614-11	SWITCH, PUSH (3 KEY) (Hi8 MP,ME/MP,REC PROOF)	
S002	1-572-688-11	SWITCH, PUSH (1 KEY)(C.C.DOWN)	
1-658-213-11 FP-355 FLEXIBLE BOARD ***** (Ref.No.;20000 Series)			
< DIODE >			
D001	8-719-988-42	DIODE GL453 (TAPE LED)	
1-658-214-11 FP-356 FLEXIBLE BOARD ***** (Ref.No.;20000 Series)			
3-965-551-01	HOLDER (S), SENSOR	< TRANSISTOR >	
Q001	8-729-907-25	PHOTO TRANSISTOR PT4850F (TAPE TOP)	
A-7074-192-A	LB-062 BOARD, COMPLETE (TR818) ***** (Ref.No.;10000 Series)	< CAPACITOR >	
C4601	1-113-682-11	TANTAL. CHIP 33uF 20% 10V	
C4602	1-127-760-11	CERAMIC CHIP 4.7uF 10% 6.3V	
C4603	1-115-464-91	CERAMIC CHIP 0.0022uF 10% 630V	
C4604	1-107-826-11	CERAMIC CHIP 0.1uF 10% 16V	
< CONNECTOR >			
CN4601	1-764-516-21	CONNECTOR, FFC/FPC (ZIF) 6P	
< IC >			
IC4601	8-759-485-79	IC TC7SET08FU(TE85R)	

Ref. No.	Part No.	Description	Remarks
< COIL >			
L4601	1-412-031-11	INDUCTOR CHIP 47uH	
L4602	1-469-525-91	INDUCTOR 10uH	
< FLUORESCENT INDICATOR >			
△ND4601	1-517-933-11	FLUORESCENT TUBE (0.44)	
< TRANSISTOR >			
Q4601	8-729-039-24	TRANSISTOR FX216-TL1	
< RESISTOR >			
R4601	1-216-808-11	METAL CHIP 82 5% 1/16W	
R4604	1-216-853-11	METAL CHIP 470K 5% 1/16W	
< TRANSFORMER >			
△T4601	1-435-225-21	TRANSFORMER, INVERTER	
A-7074-659-A MI-040 BOARD, COMPLETE (TR618/TR618E/TR718E) *****			
A-7074-661-A MI-040 BOARD, COMPLETE (TR818) *****			
A-7074-665-A MI-041 BOARD, COMPLETE (TRV98) *****			
A-7074-682-A MI-041 BOARD, COMPLETE (TRV78/TRV78E/TRV98E) *****			
A-7074-683-A MI-040 BOARD, COMPLETE (TR728E) *****			
A-7074-700-A MI-041 BOARD, COMPLETE (TRV58/TRV58E) *****			
A-7074-707-A MI-041 BOARD, COMPLETE (TRV68/TRV88) *****			
A-7074-719-A MI-041 BOARD, COMPLETE (TRV49/TRV49E/TRV59E) ***** (Ref.No.;10000 Series)			
< CAPACITOR >			
C758	1-124-778-00	ELECT CHIP 22uF 20% 6.3V (TR818/TRV68/TRV78/TRV78E/TRV88/TRV98/TRV98E)	
C759	1-125-777-11	CERAMIC CHIP 0.1uF 10% 10V (TR818/TRV68/TRV78/TRV78E/TRV88/TRV98/TRV98E)	
C762	1-124-778-00	ELECT CHIP 22uF 20% 6.3V (TR818/TRV68/TRV78/TRV78E/TRV88/TRV98/TRV98E)	
C763	1-125-777-11	CERAMIC CHIP 0.1uF 10% 10V (TR818/TRV68/TRV78/TRV78E/TRV88/TRV98/TRV98E)	
C764	1-164-943-11	CERAMIC CHIP 0.01uF 10% 16V	
C768	1-164-343-11	CERAMIC CHIP 0.056uF 10% 25V (TR818/TRV68/TRV78/TRV78E/TRV88/TRV98/TRV98E)	
C772	1-164-343-11	CERAMIC CHIP 0.056uF 10% 25V (TR818/TRV68/TRV78/TRV78E/TRV88/TRV98/TRV98E)	
C774	1-164-343-11	CERAMIC CHIP 0.056uF 10% 25V (TR818/TRV68/TRV78/TRV78E/TRV88/TRV98/TRV98E)	
C775	1-110-666-11	ELECT CHIP 22uF 20% 6.3V (TR818/TRV68/TRV78/TRV78E/TRV88/TRV98/TRV98E)	
C776	1-107-826-11	CERAMIC CHIP 0.1uF 10% 16V	

Note :
The components identified by mark △ or dotted line with mark △ are critical for safety. Replace only with part number specified.

Note :
Les composants identifiés par une marque △ sont critiques pour la sécurité. Ne les remplacer que par une pièce portant le numéro spécifié.

Ref. No.	Part No.	Description	Remarks	Ref. No.	Part No.	Description	Remarks
C777	1-164-343-11	CERAMIC CHIP 0.056uF 10% 25V (TR818/TRV68/TRV78/TRV78E/TRV88/TRV98/TRV98E)		C3925	1-125-777-11	CERAMIC CHIP 0.1uF 10% 10V (TRV98)	
C781	1-115-467-11	CERAMIC CHIP 0.22uF 10% 10V		C3926	1-164-943-11	CERAMIC CHIP 0.01uF 10% 16V (TRV98)	
C782	1-162-970-11	CERAMIC CHIP 0.01uF 10% 25V		C3929	1-104-847-11	TANTAL. CHIP 22uF 20% 4V (TRV98)	
C784	1-110-666-11	ELECT CHIP 22uF 20% 6.3V (TR818/TRV68/TRV78/TRV78E/TRV88/TRV98/TRV98E)		C3930	1-164-943-11	CERAMIC CHIP 0.01uF 10% 16V (TRV98)	
C785	1-164-227-11	CERAMIC CHIP 0.022uF 10% 25V		C3931	1-164-943-11	CERAMIC CHIP 0.01uF 10% 16V (TRV98)	
C788	1-164-227-11	CERAMIC CHIP 0.022uF 10% 25V		C3932	1-110-453-11	ELECT CHIP 4.7uF 20% 16V	
C789	1-110-501-11	CERAMIC CHIP 0.33uF 10% 16V (TR818/TRV68/TRV78/TRV78E/TRV88/TRV98/TRV98E)		C3933	1-125-777-11	CERAMIC CHIP 0.1uF 10% 10V	
C791	1-164-943-11	CERAMIC CHIP 0.01uF 10% 16V (TR818/TRV68/TRV78/TRV78E/TRV88/TRV98/TRV98E)		C3934	1-125-777-11	CERAMIC CHIP 0.1uF 10% 10V (TRV98)	
C794	1-110-410-11	ELECT CHIP 10uF 20% 6.3V (TR818/TRV68/TRV78/TRV78E/TRV88/TRV98/TRV98E)		< CONNECTOR >			
C799	1-115-467-11	CERAMIC CHIP 0.22uF 10% 10V		* CN752	1-695-320-21	PIN, CONNECTOR (1.5MM)(SMD) 2P	
C800	1-110-446-11	ELECT CHIP 10uF 20% 6.3V		CN753	1-779-336-11	CONNECTOR, FFC/FPC 24P	
C808	1-110-446-11	ELECT CHIP 10uF 20% 6.3V		< DIODE >			
C809	1-126-205-11	ELECT CHIP 47uF 20% 6.3V		D752	8-719-073-01	DIODE MA111-(K8).S0 (TR728E/TRV49/TRV49E/TRV59E/ TRV78/TRV78E/TRV98/TRV98E)	
C3901	1-125-837-91	CERAMIC CHIP 1uF 10% 6.3V (TRV98)		D753	8-719-070-91	DIODE TLSU1008(T05,SOY)	
C3904	1-164-943-11	CERAMIC CHIP 0.01uF 10% 16V (TRV98)		D754	8-719-073-01	DIODE MA111-(K8).S0	
C3905	1-117-863-11	CERAMIC CHIP 0.47uF 10% 6.3V (TRV98)		D755	8-719-073-01	DIODE MA111-(K8).S0	
C3906	1-117-863-11	CERAMIC CHIP 0.47uF 10% 6.3V (TRV98)		D3901	8-719-067-44	DIODE CL-310IRS-X-TU (TRV98)	
C3907	1-125-837-91	CERAMIC CHIP 1uF 10% 6.3V (TRV98)		D3902	8-719-083-13	DIODE DCS2815 (TRV98)	
C3908	1-125-837-91	CERAMIC CHIP 1uF 10% 6.3V (TRV98)		D3903	8-719-067-44	DIODE CL-310IRS-X-TU	
C3909	1-164-943-11	CERAMIC CHIP 0.01uF 10% 16V (TRV98)		< IC >			
C3910	1-135-181-11	TANTALUM CHIP 4.7uF 20% 10V (TRV98)		IC751	8-749-012-83	IC RS-180-T (TR728E/TRV78/TRV78E/TRV98E)	
C3911	1-164-943-11	CERAMIC CHIP 0.01uF 10% 16V (TRV98)		IC751	8-749-018-83	IC PNA4S13M02 (TRV49/TRV49E/TRV59E/TRV98)	
C3912	1-110-410-11	ELECT CHIP 10uF 20% 6.3V (TRV98)		IC752	8-759-712-78	IC BH7871FV-E2	
C3913	1-164-668-11	CERAMIC CHIP 510PF 5% 50V (TRV98)		IC753	8-759-489-19	IC UPC6756GR-8JG-E2 (TRV78/TRV78E/TRV98E)	
C3914	1-164-943-11	CERAMIC CHIP 0.01uF 10% 16V (TRV98)		IC753	8-759-637-19	IC NJM3230V(TE2) (TR818/TRV68/TRV88/TRV98)	
C3915	1-164-943-11	CERAMIC CHIP 0.01uF 10% 16V (TRV98)		IC3901	8-759-566-96	IC AN2920FHQ-EB (TRV98)	
C3916	1-125-837-91	CERAMIC CHIP 1uF 10% 6.3V (TRV98)		< COIL >			
C3917	1-125-777-11	CERAMIC CHIP 0.1uF 10% 10V (TRV98)		L751	1-469-525-91	INDUCTOR 10uH (TR818/TRV68/TRV78/TRV78E/TRV88/TRV98/TRV98E)	
C3918	1-162-913-11	CERAMIC CHIP 8PF 0.50PF 50V (TRV98)		L3902	1-469-525-91	INDUCTOR 10uH (TRV98)	
C3919	1-117-863-11	CERAMIC CHIP 0.47uF 10% 6.3V (TRV98)		L3903	1-412-948-11	INDUCTOR 5.6uH (TRV98)	
C3920	1-117-863-11	CERAMIC CHIP 0.47uF 10% 6.3V (TRV98)		L3904	1-412-957-11	INDUCTOR 33uH (TRV98)	
C3921	1-162-921-11	CERAMIC CHIP 33PF 5% 50V (TRV98)		L3905	1-412-957-11	INDUCTOR 33uH (TRV98)	
C3922	1-125-837-91	CERAMIC CHIP 1uF 10% 6.3V (TRV98)		L3906	1-469-525-91	INDUCTOR 10uH (TRV98)	
C3923	1-162-922-11	CERAMIC CHIP 39PF 5% 50V (TRV98)		< TRANSISTOR >			
C3924	1-125-837-91	CERAMIC CHIP 1uF 10% 6.3V (TRV98)		Q3901	8-729-037-53	TRANSISTOR 2SA1832F-Y/GR(TPL3) (TRV98)	
				Q3902	8-729-026-48	TRANSISTOR 2SA1037AK-T146-Q (TRV98)	
				Q3903	8-729-920-85	TRANSISTOR 2SD1664-T100-QR (TRV98)	
				Q3904	8-729-052-52	TRANSISTOR 2SC4738F-Y/GR(TPL3) (EXCEPT TRV98)	

MI-040

MI-041

PD-131

Ref. No.	Part No.	Description	Remarks
< RESISTOR >			
R757	1-216-825-11	METAL CHIP 2.2K 5%	1/16W
R769	1-216-832-11	METAL CHIP 8.2K 5%	1/16W
R774	1-216-836-11	METAL CHIP 18K 5%	1/16W
R775	1-216-832-11	METAL CHIP 8.2K 5%	1/16W
R776	1-216-864-91	SHORT 0	
R779	1-216-857-11	METAL CHIP 1M 5%	1/16W (TR818/TRV68/TRV78/TRV78E/TRV88/TRV98/TRV98E)
R780	1-216-833-11	METAL CHIP 10K 5%	1/16W (TR818/TRV68/TRV78/TRV78E/TRV88/TRV98/TRV98E)
R782	1-216-833-11	METAL CHIP 10K 5%	1/16W (TR818/TRV68/TRV78/TRV78E/TRV88/TRV98/TRV98E)
R783	1-216-857-11	METAL CHIP 1M 5%	1/16W (TR818/TRV68/TRV78/TRV78E/TRV88/TRV98/TRV98E)
R785	1-216-835-11	METAL CHIP 15K 5%	1/16W (TR818/TRV68/TRV78/TRV78E/TRV88/TRV98/TRV98E)
R788	1-216-839-11	METAL CHIP 33K 5%	1/16W
R797	1-216-824-11	METAL CHIP 1.8K 5%	1/16W
R3901	1-216-839-11	METAL CHIP 33K 5%	1/16W (TRV98)
R3902	1-216-829-11	METAL CHIP 4.7K 5%	1/16W (TRV98)
R3903	1-216-839-11	METAL CHIP 33K 5%	1/16W (TRV98)
R3904	1-216-834-11	METAL CHIP 12K 5%	1/16W (TRV98)
R3905	1-216-857-11	METAL CHIP 1M 5%	1/16W (TRV98)
R3907	1-218-879-11	METAL CHIP 22K 0.5%	1/16W (TRV98)
R3908	1-216-815-11	METAL CHIP 330 5%	1/16W (TRV98)
R3909	1-216-821-11	METAL CHIP 1K 5%	1/16W (TRV98)
R3912	1-216-819-11	METAL CHIP 680 5%	1/16W (TRV98)
R3913	1-216-847-11	METAL CHIP 150K 5%	1/16W (TRV98)
R3914	1-216-847-11	METAL CHIP 150K 5%	1/16W (TRV98)
R3915	1-216-818-11	METAL CHIP 560 5%	1/16W (TRV98)
R3916	1-216-831-11	METAL CHIP 6.8K 5%	1/16W (TRV98)
R3917	1-216-817-11	METAL CHIP 470 5%	1/16W (TRV98)
R3919	1-216-823-11	METAL CHIP 1.5K 5%	1/16W (TRV98)
R3920	1-216-817-11	METAL CHIP 470 5%	1/16W (TRV98)
R3921	1-216-817-11	METAL CHIP 470 5%	1/16W (TRV98)
R3922	1-216-864-91	SHORT 0	(TRV98)
R3923	1-216-817-11	METAL CHIP 470 5%	1/16W
R3924	1-216-295-11	SHORT 0	(TRV98)
R3925	1-216-001-00	METAL CHIP 10 5%	1/10W (TRV98)
R3925	1-216-027-00	METAL CHIP 120 5%	1/10W (EXCEPT TRV98)
R3926	1-216-800-11	RES-CHIP 18 5%	1/16W (TRV98)

Ref. No.	Part No.	Description	Remarks
R3927	1-216-295-11	SHORT 0	(EXCEPT TRV98)
R3929	1-216-027-00	METAL CHIP 120 5%	1/10W (EXCEPT TRV98)
R3931	1-216-834-11	METAL CHIP 12K 5%	1/16W (TRV98)
R3948	1-216-295-11	SHORT 0	(EXCEPT TRV98)
< COMPOSITION CIRCUIT BLOCK >			
RB751	1-239-702-81	RESISTOR, NETWORK 22K	(TR818/TRV68/TRV78/TRV78E/TRV88/TRV98/TRV98E)
RB752	1-239-702-81	RESISTOR, NETWORK 22K	(TR818/TRV68/TRV78/TRV78E/TRV88/TRV98/TRV98E)
< SENSOR >			
SE751	1-418-042-11	SENSOR, ANGULAR VELOCITY (PITCH)	(TR818/TRV68/TRV78/TRV78E/TRV88/TRV98/TRV98E)
SE752	1-418-042-21	SENSOR, ANGULAR VELOCITY (YAW)	(TR818/TRV68/TRV78/TRV78E/TRV88/TRV98/TRV98E)
A-7074-667-A	PD-131 BOARD, COMPLETE (TRV98/TRV98E) *****		
A-7074-680-A	PD-131 BOARD, COMPLETE (TRV49/TRV49E/TRV58/TRV58E/ TRV59E/TRV68/TRV78/TRV78E) *****		
A-7074-701-A	PD-131 BOARD, COMPLETE (TRV88) ***** (Ref.No.;10000 Series)		
< CAPACITOR >			
C5501	1-135-201-11	TANTALUM CHIP 10uF 20%	4V
C5503	1-125-777-11	CERAMIC CHIP 0.1uF 10%	10V
C5504	1-125-777-11	CERAMIC CHIP 0.1uF 10%	10V
C5505	1-164-943-11	CERAMIC CHIP 0.01uF 10%	16V
C5506	1-164-943-11	CERAMIC CHIP 0.01uF 10%	16V
C5507	1-164-943-11	CERAMIC CHIP 0.01uF 10%	16V
C5509	1-126-602-11	ELECT CHIP 3.3uF 20%	50V
C5510	1-164-943-11	CERAMIC CHIP 0.01uF 10%	16V
C5511	1-164-739-11	CERAMIC CHIP 560PF 5%	50V
C5512	1-125-777-11	CERAMIC CHIP 0.1uF 10%	10V
C5513	1-125-777-11	CERAMIC CHIP 0.1uF 10%	10V
C5514	1-119-750-11	TANTAL. CHIP 22uF 20%	6.3V
C5515	1-164-357-11	CERAMIC CHIP 0.001uF 5%	50V
C5516	1-162-927-11	CERAMIC CHIP 100PF 5%	50V
C5517	1-107-826-11	CERAMIC CHIP 0.1uF 10%	16V
C5518	1-107-826-11	CERAMIC CHIP 0.1uF 10%	16V
C5519	1-107-826-11	CERAMIC CHIP 0.1uF 10%	16V
C5520	1-124-779-00	ELECT CHIP 10uF 20%	16V
C5521	1-127-573-11	CERAMIC CHIP 1uF 10%	16V
C5522	1-125-777-11	CERAMIC CHIP 0.1uF 10%	10V
C5523	1-125-777-11	CERAMIC CHIP 0.1uF 10%	10V
C5524	1-127-573-11	CERAMIC CHIP 1uF 10%	16V
C5527	1-164-943-11	CERAMIC CHIP 0.01uF 10%	16V
C5528	1-126-193-11	ELECT 1uF 20%	50V
C5530	1-164-943-11	CERAMIC CHIP 0.01uF 10%	16V

Ref. No.	Part No.	Description	Remarks	Ref. No.	Part No.	Description	Remarks
C5531	1-164-943-11	CERAMIC CHIP 0.01uF 10%	16V	< RESISTOR >			
C5603	1-164-657-11	CERAMIC CHIP 0.015uF 10%	50V				
C5604	1-125-777-11	CERAMIC CHIP 0.1uF 10%	10V				
C5605	1-125-777-11	CERAMIC CHIP 0.1uF 10%	10V				
△C5606	1-131-959-91	CERAMIC CHIP 12PF 10%	3KV				
C5607	1-115-566-11	CERAMIC CHIP 4.7uF 10%	10V	R5501	1-216-853-11	METAL CHIP 470K 5%	1/16W
< CONNECTOR >				R5503	1-218-893-11	METAL CHIP 82K 0.5%	1/16W
CN5501	1-815-031-11	CONNECTOR, FFC/FPC (ZIF) 24P		(TRV88/TRV98/TRV98E)			
*CN5502	1-573-984-11	CONNECTOR, BOARD TO BOARD 10P		R5503	1-218-895-11	METAL CHIP 100K 0.5%	1/16W
CN5601	1-764-709-11	CONNECTOR, FFC/FPC (LIF) 10P		(TRV49/TRV49E/TRV58/TRV58E/ TRV59E/TRV68/TRV78/TRV78E)			
CN5701	1-794-998-21	PIN, CONNECTOR 20P		R5505	1-216-835-11	METAL CHIP 15K 5%	1/16W
CN5702	1-573-346-21	CONNECTOR, FFC/FPC 6P		R5506	1-216-826-11	METAL CHIP 2.7K 5%	1/16W
< DIODE >				R5507	1-216-841-11	METAL CHIP 47K 5%	1/16W
D5502	8-713-102-80	DIODE 1T369-01-T8A		R5508	1-216-843-11	METAL CHIP 68K 5%	1/16W
D5503	8-719-073-01	DIODE MA111-(K8).SO		R5509	1-216-837-11	METAL CHIP 22K 5%	1/16W
D5503	8-719-988-61	DIODE 1SS355TE-17		R5510	1-216-843-11	METAL CHIP 68K 5%	1/16W
D5601	8-719-073-01	DIODE MA111-(K8).SO		R5511	1-216-857-11	METAL CHIP 1M 5%	1/16W
D5601	8-719-988-61	DIODE 1SS355TE-17		R5512	1-216-845-11	METAL CHIP 100K 5%	1/16W
< FERRITE BEAD >				R5513	1-216-857-11	METAL CHIP 1M 5%	1/16W
FB003	1-414-760-21	FERRITE 0UH		R5515	1-216-864-91	SHORT 0	
FB5501	1-414-760-21	FERRITE 0UH		R5516	1-216-833-11	METAL CHIP 10K 5%	1/16W
FB5501	1-414-760-21	FERRITE 0UH		R5519	1-216-864-91	SHORT 0	
FB5501	1-414-760-21	FERRITE 0UH		R5521	1-216-841-11	METAL CHIP 47K 5%	1/16W
FB5501	1-500-329-21	FERRITE 0UH		R5522	1-216-821-11	METAL CHIP 1K 5%	1/16W
FB5502	1-414-760-21	FERRITE 0UH		(TRV49/TRV49E/TRV58/TRV58E/ TRV59E/TRV68/TRV78/TRV78E)			
FB5502	1-414-760-21	FERRITE 0UH		R5522	1-216-829-11	METAL CHIP 4.7K 5%	1/16W
FB5502	1-414-760-21	FERRITE 0UH		(TRV88)			
FB5502	1-500-329-21	FERRITE 0UH		R5522	1-216-830-11	METAL CHIP 5.6K 5%	1/16W
< IC >				(TRV98/TRV98E)			
IC5501	8-759-660-92	IC RB5P003AM1		R5523	1-216-864-91	SHORT 0	
IC5502	8-759-714-77	IC LZ9FF474		R5531	1-216-848-11	METAL CHIP 180K 5%	1/16W
IC5601	8-759-564-49	IC TC7W53FU(TE12R)		R5532	1-216-845-11	METAL CHIP 100K 5%	1/16W
IC5602	8-759-075-70	IC TA75S393F-TE85R		R5533	1-216-857-11	METAL CHIP 1M 5%	1/16W
< COIL >				R5534	1-216-864-91	SHORT 0	
L001	1-419-354-21	INDUCTOR 22uH		R5535	1-216-864-91	SHORT 0	
L5501	1-469-525-91	INDUCTOR 10uH		R5601	1-216-824-11	METAL CHIP 1.8K 5%	1/16W
L5502	1-469-525-91	INDUCTOR 10uH		R5602	1-216-845-11	METAL CHIP 100K 5%	1/16W
L5503	1-412-949-21	INDUCTOR 6.8uH		R5603	1-216-834-11	METAL CHIP 12K 5%	1/16W
(TRV88/TRV98/TRV98E)				R5604	1-216-824-11	METAL CHIP 1.8K 5%	1/16W
L5503	1-412-956-21	INDUCTOR 27uH		R5606	1-216-837-11	METAL CHIP 22K 5%	1/16W
(TRV49/TRV49E/TRV58/TRV58E/ TRV59E/TRV68/TRV78/TRV78E)				R5607	1-216-817-11	METAL CHIP 470 5%	1/16W
L5601	1-419-387-11	INDUCTOR 100uH		R5610	1-216-864-91	SHORT 0	
< TRANSISTOR >				R5702	1-216-833-11	METAL CHIP 10K 5%	1/16W
Q5502	8-729-041-23	TRANSISTOR NDS356AP		< COMPOSITION CIRCUIT BLOCK >			
Q5503	8-729-054-48	TRANSISTOR N1B04FE-Y/GR(TPLR3)		RB5501	1-234-372-21	RES, NETWORK 100X4 (1005)	
Q5504	8-729-054-48	TRANSISTOR N1B04FE-Y/GR(TPLR3)		RB5502	1-239-698-11	RESISTOR, NETWORK 10K	
Q5505	8-729-042-29	TRANSISTOR RN1104F(TPL3)		RB5503	1-239-661-81	RESISTOR, NETWORK 1M	
Q5601	8-729-042-29	TRANSISTOR RN1104F(TPL3)		RB5601	1-239-698-11	RESISTOR, NETWORK 10K	
< TRANSFORMER >				(TRV49/TRV49E/TRV58/TRV58E/ TRV59E/TRV68/TRV78/TRV78E)			
Q5602	8-729-039-43	TRANSISTOR FP216-TL		RB5601	1-239-701-81	RESISTOR, NETWORK 18K	
< TRANSFORMER >				(TRV88/TRV98/TRV98E)			
				△T5601	1-435-227-11	TRANSFORMER, INVERTER	

<p>Note : The components identified by mark △ or dotted line with mark △ are critical for safety. Replace only with part number specified.</p>	<p>Note : Les composants identifiés par une marque △ sont critiques pour la sécurité. Ne les remplacer que par une pièce portant le numéro spécifié.</p>
---	---

VC-251

Ref. No.	Part No.	Description	Remarks	Ref. No.	Part No.	Description	Remarks
A-7096-402-A	VC-251 BOARD, COMPLETE (SERVICE)	(TR618E)	*****	C034	1-162-974-11	CERAMIC CHIP 0.01uF	50V
A-7096-403-A	VC-251 BOARD, COMPLETE (SERVICE)	(TR818E)	*****			(TRV49/TRV49E/TRV58/TRV58E/TRV59E/TRV68/ TRV78/TRV78E/TRV88/TRV98/TRV98E)	
A-7096-404-A	VC-251 BOARD, COMPLETE (SERVICE)	(TR618E/TR718E/TR728E)	*****	C035	1-127-760-11	CERAMIC CHIP 4.7uF	10% 6.3V
A-7096-405-A	VC-251 BOARD, COMPLETE (SERVICE)	(TRV68/TRV78/TRV88/TRV98)	*****	C036	1-127-760-11	CERAMIC CHIP 4.7uF	10% 6.3V
A-7096-406-A	VC-251 BOARD, COMPLETE (SERVICE)	(TRV78E/TRV98E)	*****	C037	1-127-760-11	CERAMIC CHIP 4.7uF	10% 6.3V
A-7096-409-A	VC-251 BOARD, COMPLETE (SERVICE)	(TRV49/TRV58)	*****	C038	1-127-688-21	TANTAL. CHIP 10uF	20% 6.3V
A-7096-456-A	VC-251 BOARD, COMPLETE (SERVICE)	(TRV49E/TRV58E/TRV59E)	*****	C039	1-135-149-21	TANTALUM CHIP 2.2uF	20% 10V
	(Ref.No.:10000 Series)			C040	1-119-750-11	TANTAL. CHIP 22uF	20% 6.3V
	< CAPACITOR >			C041	1-125-837-91	CERAMIC CHIP 1uF	10% 6.3V
C001	1-162-960-11	CERAMIC CHIP 220PF	10% 50V	C042	1-164-506-11	CERAMIC CHIP 4.7uF	16V
C002	1-125-777-11	CERAMIC CHIP 0.1uF	10% 10V	C043	1-164-506-11	CERAMIC CHIP 4.7uF	16V
C003	1-119-923-81	CERAMIC CHIP 0.047uF	10% 10V	C045	1-119-749-11	TANTAL. CHIP 33uF	20% 4V
C004	1-125-777-11	CERAMIC CHIP 0.1uF	10% 10V	C046	1-119-750-11	TANTAL. CHIP 22uF	20% 6.3V
C005	1-125-777-11	CERAMIC CHIP 0.1uF	10% 10V	C047	1-164-505-11	CERAMIC CHIP 2.2uF	16V
C008	1-164-943-11	CERAMIC CHIP 0.01uF	10% 16V			(TR818/TRV49/TRV49E/TRV58/TRV58E/TRV59E/ TRV68/TRV78/TRV78E/TRV88/TRV98/TRV98E)	
C009	1-164-172-11	CERAMIC CHIP 0.0056uF	10% 25V	C048	1-164-156-11	CERAMIC CHIP 0.1uF	25V
C010	1-107-819-11	CERAMIC CHIP 0.022uF	10% 16V			(TRV49/TRV49E/TRV58/TRV58E/TRV59E/TRV68/ TRV78/TRV78E/TRV88/TRV98/TRV98E)	
C011	1-107-819-11	CERAMIC CHIP 0.022uF	10% 16V	C049	1-127-688-21	TANTAL. CHIP 10uF	20% 6.3V
C012	1-162-962-11	CERAMIC CHIP 470PF	10% 50V	C050	1-135-149-21	TANTALUM CHIP 2.2uF	20% 10V
C013	1-162-968-11	CERAMIC CHIP 0.0047uF	10% 50V	C051	1-119-750-11	TANTAL. CHIP 22uF	20% 6.3V
C014	1-162-965-11	CERAMIC CHIP 0.0015uF	10% 50V	C052	1-127-688-21	TANTAL. CHIP 10uF	20% 6.3V
C015	1-162-966-11	CERAMIC CHIP 0.0022uF	10% 50V	C053	1-125-777-11	CERAMIC CHIP 0.1uF	10% 10V
	(TRV49/TRV49E/TRV58/TRV58E/TRV59E/TRV68/ TRV78/TRV78E/TRV88/TRV98/TRV98E)			C054	1-164-506-11	CERAMIC CHIP 4.7uF	16V
C016	1-164-937-11	CERAMIC CHIP 0.001uF	10% 16V	C055	1-164-506-11	CERAMIC CHIP 4.7uF	16V
C018	1-162-962-11	CERAMIC CHIP 470PF	10% 50V	C056	1-164-346-11	CERAMIC CHIP 1uF	16V
	(TRV49/TRV49E/TRV58/TRV58E/TRV59E/TRV68/ TRV78/TRV78E/TRV88/TRV98/TRV98E)					(TR818)	
C019	1-164-937-11	CERAMIC CHIP 0.001uF	10% 16V	C057	1-164-505-11	CERAMIC CHIP 2.2uF	16V
C020	1-117-808-91	CERAMIC CHIP 10uF	10% 10V			(TRV49/TRV49E/TRV58/TRV58E/TRV59E/TRV68/ TRV78/TRV78E/TRV88/TRV98/TRV98E)	
C021	1-164-937-11	CERAMIC CHIP 0.001uF	10% 16V	C058	1-164-505-11	CERAMIC CHIP 2.2uF	16V
C022	1-164-937-11	CERAMIC CHIP 0.001uF	10% 16V			(TRV49/TRV49E/TRV58/TRV58E/TRV59E/TRV68/ TRV78/TRV78E/TRV88/TRV98/TRV98E)	
C023	1-164-937-11	CERAMIC CHIP 0.001uF	10% 16V	C059	1-164-943-11	CERAMIC CHIP 0.01uF	10% 16V
C024	1-164-937-11	CERAMIC CHIP 0.001uF	10% 16V	C061	1-119-750-11	TANTAL. CHIP 22uF	20% 6.3V
C025	1-125-777-11	CERAMIC CHIP 0.1uF	10% 10V	C071	1-164-943-11	CERAMIC CHIP 0.01uF	10% 16V
C026	1-115-566-11	CERAMIC CHIP 4.7uF	10% 10V			(TRV49/TRV49E/TRV58/TRV58E/TRV59E/TRV68/ TRV78/TRV78E/TRV88/TRV98/TRV98E)	
	(TRV49/TRV49E/TRV58/TRV58E/TRV59E/TRV68/ TRV78/TRV78E/TRV88/TRV98/TRV98E)			C072	1-164-943-11	CERAMIC CHIP 0.01uF	10% 16V
C027	1-115-566-11	CERAMIC CHIP 4.7uF	10% 10V			(TRV49/TRV49E/TRV58/TRV58E/TRV59E/TRV68/ TRV78/TRV78E/TRV88/TRV98/TRV98E)	
C028	1-115-566-11	CERAMIC CHIP 4.7uF	10% 10V	C101	1-164-943-11	CERAMIC CHIP 0.01uF	10% 16V
C029	1-115-566-11	CERAMIC CHIP 4.7uF	10% 10V	C102	1-104-752-11	TANTAL. CHIP 33uF	20% 6.3V
C030	1-115-566-11	CERAMIC CHIP 4.7uF	10% 10V	C103	1-164-943-11	CERAMIC CHIP 0.01uF	10% 16V
	(TRV49/TRV49E/TRV58/TRV58E/TRV59E/TRV68/ TRV78/TRV78E/TRV88/TRV98/TRV98E)			C104	1-164-943-11	CERAMIC CHIP 0.01uF	10% 16V
C031	1-127-760-11	CERAMIC CHIP 4.7uF	10% 6.3V	C106	1-107-819-11	CERAMIC CHIP 0.022uF	10% 16V
C032	1-115-566-11	CERAMIC CHIP 4.7uF	10% 10V	C107	1-107-819-11	CERAMIC CHIP 0.022uF	10% 16V
	(TRV49/TRV49E/TRV58/TRV58E/TRV59E/TRV68/ TRV78/TRV78E/TRV88/TRV98/TRV98E)			C108	1-164-943-11	CERAMIC CHIP 0.01uF	10% 16V
C033	1-127-760-11	CERAMIC CHIP 4.7uF	10% 6.3V	C109	1-164-943-11	CERAMIC CHIP 0.01uF	10% 16V
				C110	1-162-927-11	CERAMIC CHIP 100PF	5% 50V
				C111	1-164-217-11	CERAMIC CHIP 150PF	5% 50V
				C112	1-162-926-11	CERAMIC CHIP 82PF	5% 50V
				C113	1-125-777-11	CERAMIC CHIP 0.1uF	10% 10V
				C114	1-125-777-11	CERAMIC CHIP 0.1uF	10% 10V
				C115	1-162-927-11	CERAMIC CHIP 100PF	5% 50V
				C116	1-164-943-11	CERAMIC CHIP 0.01uF	10% 16V
				C117	1-164-943-11	CERAMIC CHIP 0.01uF	10% 16V
				C118	1-164-943-11	CERAMIC CHIP 0.01uF	10% 16V

Ref. No.	Part No.	Description	Remarks	Ref. No.	Part No.	Description	Remarks
C119	1-127-688-21	TANTAL. CHIP	10uF 20% 6.3V	C238	1-164-943-11	CERAMIC CHIP	0.01uF 10% 16V
C121	1-125-777-11	CERAMIC CHIP	0.1uF 10% 10V	C246	1-164-943-11	CERAMIC CHIP	0.01uF 10% 16V
C123	1-164-943-11	CERAMIC CHIP	0.01uF 10% 16V	C247	1-126-601-11	ELECT CHIP	2.2uF 20% 50V
C124	1-164-943-11	CERAMIC CHIP	0.01uF 10% 16V	C248	1-126-601-11	ELECT CHIP	2.2uF 20% 50V
C125	1-164-943-11	CERAMIC CHIP	0.01uF 10% 16V	C249	1-126-246-11	ELECT CHIP	220uF 20% 4V
C126	1-164-943-11	CERAMIC CHIP	0.01uF 10% 16V	C250	1-126-246-11	ELECT CHIP	220uF 20% 4V
C127	1-164-937-11	CERAMIC CHIP	0.001uF 10% 16V	C252	1-124-779-00	ELECT CHIP	10uF 20% 16V
C128	1-164-943-11	CERAMIC CHIP	0.01uF 10% 16V	C271	1-162-919-11	CERAMIC CHIP	22PF 5% 50V
C129	1-162-968-11	CERAMIC CHIP	0.0047uF 10% 50V	C272	1-164-937-11	CERAMIC CHIP	0.001uF 10% 16V
C130	1-164-943-11	CERAMIC CHIP	0.01uF 10% 16V	C273	1-162-919-11	CERAMIC CHIP	22PF 5% 50V
C131	1-164-943-11	CERAMIC CHIP	0.01uF 10% 16V	C274	1-127-688-21	TANTAL. CHIP	10uF 20% 6.3V
C132	1-164-943-11	CERAMIC CHIP	0.01uF 10% 16V			(TR618/TR618E/TR718E/TR728E/TRV49/ TRV49E/TRV58/TRV58E/TRV59E)	
C133	1-164-943-11	CERAMIC CHIP	0.01uF 10% 16V	C275	1-164-943-11	CERAMIC CHIP	0.01uF 10% 16V
C134	1-117-863-11	CERAMIC CHIP	0.47uF 10% 6.3V			(TR618/TR618E/TR718E/TR728E/TRV49/ TRV49E/TRV58/TRV58E/TRV59E)	
C135	1-164-943-11	CERAMIC CHIP	0.01uF 10% 16V	C276	1-115-467-11	CERAMIC CHIP	0.22uF 10% 10V
C136	1-164-943-11	CERAMIC CHIP	0.01uF 10% 16V	C277	1-164-943-11	CERAMIC CHIP	0.01uF 10% 16V
C151	1-125-837-91	CERAMIC CHIP	1uF 10% 6.3V	C278	1-131-861-91	TANTAL. CHIP	4.7uF 20% 20V
C152	1-115-566-11	CERAMIC CHIP	4.7uF 10% 10V	C279	1-127-688-21	TANTAL. CHIP	10uF 20% 6.3V
C154	1-125-777-11	CERAMIC CHIP	0.1uF 10% 10V	C280	1-125-777-11	CERAMIC CHIP	0.1uF 10% 10V
C155	1-125-777-11	CERAMIC CHIP	0.1uF 10% 10V	C281	1-125-777-11	CERAMIC CHIP	0.1uF 10% 10V
C156	1-164-392-11	CERAMIC CHIP	390PF 5% 50V	C282	1-164-937-11	CERAMIC CHIP	0.001uF 10% 16V
C157	1-125-777-11	CERAMIC CHIP	0.1uF 10% 10V	C283	1-162-913-11	CERAMIC CHIP	8PF 0.50PF 50V
C158	1-135-210-11	TANTALUM CHIP	4.7uF 20% 10V	C284	1-115-339-11	CERAMIC CHIP	0.1uF 10% 50V
C160	1-125-777-11	CERAMIC CHIP	0.1uF 10% 10V	C285	1-164-937-11	CERAMIC CHIP	0.001uF 10% 16V
C161	1-164-943-11	CERAMIC CHIP	0.01uF 10% 16V	C286	1-125-837-91	CERAMIC CHIP	1uF 10% 6.3V
C162	1-125-777-11	CERAMIC CHIP	0.1uF 10% 10V	C287	1-125-837-91	CERAMIC CHIP	1uF 10% 6.3V
C163	1-125-777-11	CERAMIC CHIP	0.1uF 10% 10V	C288	1-125-777-11	CERAMIC CHIP	0.1uF 10% 10V
C164	1-125-777-11	CERAMIC CHIP	0.1uF 10% 10V			(TRV49/TRV49E/TRV58/TRV58E/TRV59E/TRV68/ TRV78/TRV78E/TRV88/TRV98/TRV98E)	
C165	1-125-777-11	CERAMIC CHIP	0.1uF 10% 10V	C289	1-107-826-11	CERAMIC CHIP	0.1uF 10% 16V
				C290	1-125-837-91	CERAMIC CHIP	1uF 10% 6.3V
				C291	1-125-777-11	CERAMIC CHIP	0.1uF 10% 10V
C166	1-125-777-11	CERAMIC CHIP	0.1uF 10% 10V	C292	1-115-467-11	CERAMIC CHIP	0.22uF 10% 10V
				C293	1-162-962-11	CERAMIC CHIP	470PF 10% 50V
						(TRV49/TRV49E/TRV58/TRV58E/TRV59E/TRV68/ TRV78/TRV78E/TRV88/TRV98/TRV98E)	
C167	1-125-777-11	CERAMIC CHIP	0.1uF 10% 10V	C294	1-125-837-91	CERAMIC CHIP	1uF 10% 6.3V
C168	1-125-777-11	CERAMIC CHIP	0.1uF 10% 10V	C295	1-125-837-91	CERAMIC CHIP	1uF 10% 6.3V
C169	1-125-777-11	CERAMIC CHIP	0.1uF 10% 10V	C296	1-125-777-11	CERAMIC CHIP	0.1uF 10% 10V
C170	1-125-777-11	CERAMIC CHIP	0.1uF 10% 10V	C297	1-104-847-11	TANTAL. CHIP	22uF 20% 4V
C171	1-125-777-11	CERAMIC CHIP	0.1uF 10% 10V	C302	1-164-943-11	CERAMIC CHIP	0.01uF 10% 16V
C172	1-125-777-11	CERAMIC CHIP	0.1uF 10% 10V	C303	1-162-968-11	CERAMIC CHIP	0.0047uF 10% 50V
C173	1-164-943-11	CERAMIC CHIP	0.01uF 10% 16V	C304	1-127-688-21	TANTAL. CHIP	10uF 20% 6.3V
C174	1-117-863-11	CERAMIC CHIP	0.47uF 10% 6.3V	C305	1-125-777-11	CERAMIC CHIP	0.1uF 10% 10V
C175	1-125-837-91	CERAMIC CHIP	1uF 10% 6.3V	C306	1-125-777-11	CERAMIC CHIP	0.1uF 10% 10V
C176	1-125-837-91	CERAMIC CHIP	1uF 10% 6.3V	C307	1-162-962-11	CERAMIC CHIP	470PF 10% 50V
C177	1-164-943-11	CERAMIC CHIP	0.01uF 10% 16V	C308	1-164-943-11	CERAMIC CHIP	0.01uF 10% 16V
C178	1-162-965-11	CERAMIC CHIP	0.0015uF 10% 50V	C309	1-115-467-11	CERAMIC CHIP	0.22uF 10% 10V
C182	1-164-943-11	CERAMIC CHIP	0.01uF 10% 16V	C310	1-126-205-11	ELECT CHIP	47uF 20% 6.3V
C184	1-125-777-11	CERAMIC CHIP	0.1uF 10% 10V	C311	1-164-937-11	CERAMIC CHIP	0.001uF 10% 16V
C185	1-125-837-91	CERAMIC CHIP	1uF 10% 6.3V	C312	1-117-863-11	CERAMIC CHIP	0.47uF 10% 6.3V
C186	1-125-777-11	CERAMIC CHIP	0.1uF 10% 10V	C313	1-164-943-11	CERAMIC CHIP	0.01uF 10% 16V
C187	1-125-777-11	CERAMIC CHIP	0.1uF 10% 10V	C315	1-162-966-11	CERAMIC CHIP	0.0022uF 10% 50V
C188	1-125-777-11	CERAMIC CHIP	0.1uF 10% 10V	C316	1-125-837-91	CERAMIC CHIP	1uF 10% 6.3V
C190	1-125-837-91	CERAMIC CHIP	1uF 10% 6.3V	C317	1-164-943-11	CERAMIC CHIP	0.01uF 10% 16V
C195	1-125-777-11	CERAMIC CHIP	0.1uF 10% 10V	C318	1-127-688-21	TANTAL. CHIP	10uF 20% 6.3V
C221	1-125-777-11	CERAMIC CHIP	0.1uF 10% 10V	C319	1-125-777-11	CERAMIC CHIP	0.1uF 10% 10V
C223	1-110-446-11	ELECT CHIP	10uF 20% 6.3V	C352	1-124-779-00	ELECT CHIP	10uF 20% 16V
C225	1-125-837-91	CERAMIC CHIP	1uF 10% 6.3V	C354	1-124-779-00	ELECT CHIP	10uF 20% 16V
C233	1-110-423-11	ELECT CHIP	2.2uF 20% 25V	C357	1-124-778-00	ELECT CHIP	22uF 20% 6.3V
C235	1-125-837-91	CERAMIC CHIP	1uF 10% 6.3V	C358	1-164-943-11	CERAMIC CHIP	0.01uF 10% 16V
						(TRV49/TRV49E/TRV58/TRV58E/TRV59E/TRV68/ TRV78/TRV78E/TRV88/TRV98/TRV98E)	

VC-251

Ref. No.	Part No.	Description	Remarks	Ref. No.	Part No.	Description	Remarks
C359	1-124-779-00	ELECT CHIP	10uF 20% 16V	C460	1-125-777-11	CERAMIC CHIP	0.1uF 10% 10V
C361	1-126-607-11	ELECT CHIP	47uF 20% 4V	C461	1-125-777-11	CERAMIC CHIP	0.1uF 10% 10V
C363	1-115-467-11	CERAMIC CHIP	0.22uF 10% 10V (TRV49/TRV49E/TRV58/TRV58E/TRV59E/TRV68/ TRV78/TRV78E/TRV88/TRV98/TRV98E)	C462	1-125-777-11	CERAMIC CHIP	0.1uF 10% 10V
C364	1-117-863-11	CERAMIC CHIP	0.47uF 10% 6.3V	C463	1-125-777-11	CERAMIC CHIP	0.1uF 10% 10V
C365	1-124-778-00	ELECT CHIP	22uF 20% 6.3V (TRV49/TRV49E/TRV58/TRV58E/TRV59E/TRV68/ TRV78/TRV78E/TRV88/TRV98/TRV98E)	C464	1-162-960-11	CERAMIC CHIP	220PF 10% 50V
C366	1-126-602-11	ELECT CHIP	3.3uF 20% 50V	C465	1-162-968-11	CERAMIC CHIP	0.0047uF 10% 50V
C367	1-124-779-00	ELECT CHIP	10uF 20% 16V (TRV49/TRV49E/TRV58/TRV58E/TRV59E/TRV68/ TRV78/TRV78E/TRV88/TRV98/TRV98E)	C466	1-125-777-11	CERAMIC CHIP	0.1uF 10% 10V
C369	1-115-467-11	CERAMIC CHIP	0.22uF 10% 10V (TRV49/TRV49E/TRV58/TRV58E/TRV59E/TRV68/ TRV78/TRV78E/TRV88/TRV98/TRV98E)	C467	1-162-966-11	CERAMIC CHIP	0.0022uF 10% 50V
C371	1-115-467-11	CERAMIC CHIP	0.22uF 10% 10V (TRV49/TRV49E/TRV58/TRV58E/TRV59E/TRV68/ TRV78/TRV78E/TRV88/TRV98/TRV98E)	C468	1-162-962-11	CERAMIC CHIP	470PF 10% 50V
C372	1-115-467-11	CERAMIC CHIP	0.22uF 10% 10V (TRV49/TRV49E/TRV58/TRV58E/TRV59E/TRV68/ TRV78/TRV78E/TRV88/TRV98/TRV98E)	C469	1-162-966-11	CERAMIC CHIP	0.0022uF 10% 50V
C374	1-124-778-00	ELECT CHIP	22uF 20% 6.3V	C470	1-125-837-91	CERAMIC CHIP	1uF 10% 6.3V
C375	1-125-777-11	CERAMIC CHIP	0.1uF 10% 10V	C471	1-162-966-11	CERAMIC CHIP	0.0022uF 10% 50V
C380	1-125-837-91	CERAMIC CHIP	1uF 10% 6.3V	C472	1-162-968-11	CERAMIC CHIP	0.0047uF 10% 50V (TR618E/TR718E/TR728E/TRV49E/ TRV58E/TRV59E/TRV78E/TRV98E)
C381	1-125-837-91	CERAMIC CHIP	1uF 10% 6.3V	C473	1-107-819-11	CERAMIC CHIP	0.022uF 10% 16V (TR618E/TR718E/TR728E/TRV49E/ TRV58E/TRV59E/TRV78E/TRV98E)
C383	1-125-777-11	CERAMIC CHIP	0.1uF 10% 10V	C474	1-125-777-11	CERAMIC CHIP	0.1uF 10% 10V
C384	1-115-467-11	CERAMIC CHIP	0.22uF 10% 10V	C475	1-107-819-11	CERAMIC CHIP	0.022uF 10% 16V
C385	1-125-837-91	CERAMIC CHIP	1uF 10% 6.3V	C476	1-164-943-11	CERAMIC CHIP	0.01uF 10% 16V
C386	1-125-837-91	CERAMIC CHIP	1uF 10% 6.3V	C477	1-119-923-81	CERAMIC CHIP	0.047uF 10% 10V
C389	1-115-467-11	CERAMIC CHIP	0.22uF 10% 10V	C478	1-119-923-81	CERAMIC CHIP	0.047uF 10% 10V
C390	1-164-937-11	CERAMIC CHIP	0.001uF 10% 16V	C479	1-164-505-11	CERAMIC CHIP	2.2uF 16V
C392	1-164-943-11	CERAMIC CHIP	0.01uF 10% 16V	C480	1-125-777-11	CERAMIC CHIP	0.1uF 10% 10V
C393	1-164-943-11	CERAMIC CHIP	0.01uF 10% 16V	C481	1-164-937-11	CERAMIC CHIP	0.001uF 10% 16V
C394	1-117-863-11	CERAMIC CHIP	0.47uF 10% 6.3V	C482	1-164-937-11	CERAMIC CHIP	0.001uF 10% 16V
C396	1-164-943-11	CERAMIC CHIP	0.01uF 10% 16V	C483	1-162-962-11	CERAMIC CHIP	470PF 10% 50V
C397	1-162-925-11	CERAMIC CHIP	68PF 5% 50V	C484	1-162-962-11	CERAMIC CHIP	470PF 10% 50V
C398	1-115-467-11	CERAMIC CHIP	0.22uF 10% 10V	C501	1-125-777-11	CERAMIC CHIP	0.1uF 10% 10V
C401	1-125-837-91	CERAMIC CHIP	1uF 10% 6.3V	C502	1-125-777-11	CERAMIC CHIP	0.1uF 10% 10V
C402	1-125-777-11	CERAMIC CHIP	0.1uF 10% 10V	C503	1-126-607-11	ELECT CHIP	47uF 20% 4V
C403	1-162-915-11	CERAMIC CHIP	10PF 0.5PF 50V	C504	1-125-777-11	CERAMIC CHIP	0.1uF 10% 10V
C404	1-162-915-11	CERAMIC CHIP	10PF 0.5PF 50V	C506	1-164-943-11	CERAMIC CHIP	0.01uF 10% 16V
C405	1-125-777-11	CERAMIC CHIP	0.1uF 10% 10V	C507	1-164-943-11	CERAMIC CHIP	0.01uF 10% 16V
C406	1-164-943-11	CERAMIC CHIP	0.01uF 10% 16V	C508	1-164-943-11	CERAMIC CHIP	0.01uF 10% 16V
C407	1-164-943-11	CERAMIC CHIP	0.01uF 10% 16V	C509	1-164-943-11	CERAMIC CHIP	0.01uF 10% 16V
C408	1-125-777-11	CERAMIC CHIP	0.1uF 10% 10V	C510	1-164-943-11	CERAMIC CHIP	0.01uF 10% 16V
C410	1-164-943-11	CERAMIC CHIP	0.01uF 10% 16V	C511	1-125-777-11	CERAMIC CHIP	0.1uF 10% 10V
C411	1-164-943-11	CERAMIC CHIP	0.01uF 10% 16V	C512	1-125-777-11	CERAMIC CHIP	0.1uF 10% 10V
C451	1-125-777-11	CERAMIC CHIP	0.1uF 10% 10V	C513	1-107-819-11	CERAMIC CHIP	0.022uF 10% 16V
C452	1-125-777-11	CERAMIC CHIP	0.1uF 10% 10V	C514	1-162-969-11	CERAMIC CHIP	0.0068uF 10% 25V
C453	1-125-777-11	CERAMIC CHIP	0.1uF 10% 10V	C515	1-162-919-11	CERAMIC CHIP	22PF 5% 50V
C454	1-125-777-11	CERAMIC CHIP	0.1uF 10% 10V	C516	1-162-918-11	CERAMIC CHIP	18PF 5% 50V
C455	1-107-819-11	CERAMIC CHIP	0.022uF 10% 16V	C517	1-125-777-11	CERAMIC CHIP	0.1uF 10% 10V
C456	1-107-819-11	CERAMIC CHIP	0.022uF 10% 16V	C518	1-125-777-11	CERAMIC CHIP	0.1uF 10% 10V
C457	1-119-923-81	CERAMIC CHIP	0.047uF 10% 10V	C519	1-119-923-81	CERAMIC CHIP	0.047uF 10% 10V (TRV49/TRV49E/TRV58/TRV58E/TRV59E/TRV68/ TRV78/TRV78E/TRV88/TRV98/TRV98E)
C458	1-126-603-11	ELECT CHIP	4.7uF 20% 35V	C601	1-164-943-11	CERAMIC CHIP	0.01uF 10% 16V
C459	1-125-777-11	CERAMIC CHIP	0.1uF 10% 10V	C602	1-127-688-21	TANTAL. CHIP	10uF 20% 6.3V
				C603	1-125-837-91	CERAMIC CHIP	1uF 10% 6.3V
				C701	1-135-639-21	ELECT CHIP	47uF 20% 6.3V
				C708	1-115-566-11	CERAMIC CHIP	4.7uF 10% 10V (EXCEPT TR818)

Ref. No.	Part No.	Description	Remarks	Ref. No.	Part No.	Description	Remarks
		< CONNECTOR >				< FERRITE BEAD >	
* CN001	1-764-177-11	PIN, CONNECTOR (SMD)(1.5MM) 7P		FB001	1-414-760-21	FERRITE 0UH	
CN101	1-766-346-21	CONNECTOR, FFC/FPC 16P		FB003	1-414-760-21	FERRITE 0UH (TRV49/TRV49E/TRV58/TRV58E/TRV59E/TRV68/ TRV78/TRV78E/TRV88/TRV98/TRV98E)	
CN271	1-779-331-11	CONNECTOR, FFC/FPC 14P		FB101	1-414-228-11	FERRITE 0UH	
CN301	1-750-360-21	CONNECTOR, FFC/FPC (ZIF) 24P		FB102	1-414-228-11	FERRITE 0UH	
CN701	1-794-998-21	PIN, CONNECTOR 20P (TRV49/TRV49E/TRV58/TRV58E/TRV59E/TRV68/ TRV78/TRV78E/TRV88/TRV98/TRV98E)		FB152	1-414-760-21	FERRITE 0UH	
CN702	1-766-350-21	CONNECTOR, FFC/FPC 20P		FB153	1-414-760-21	FERRITE 0UH	
CN703	1-766-354-21	CONNECTOR, FFC/FPC 24P		FB154	1-414-760-21	FERRITE 0UH	
CN704	1-766-644-21	CONNECTOR, FFC/FPC 8P		FB221	1-414-760-21	FERRITE 0UH	
CN706	1-766-340-21	CONNECTOR, FFC/FPC 10P		FB271	1-414-760-21	FERRITE 0UH (TR618/TR618E/TR718E/TR728E/TRV49/ TRV49E/TRV58/TRV58E/TRV59E)	
CN707	1-766-342-21	CONNECTOR, FFC/FPC 12P		FB273	1-500-284-21	FERRITE 0UH	
CN708	1-779-334-11	CONNECTOR, FFC/FPC 20P (TR818)		FB274	1-500-284-21	FERRITE 0UH	
CN709	1-815-031-11	CONNECTOR, FFC/FPC (ZIF) 24P		FB275	1-414-760-21	FERRITE 0UH	
CN710	1-750-076-21	CONNECTOR, FFC/FPC 12P		FB276	1-500-284-21	FERRITE 0UH	
CN711	1-764-704-21	CONNECTOR, FFC/FPC (LIF) 5P		FB601	1-414-760-21	FERRITE 0UH	
CN712	1-766-345-21	CONNECTOR, FFC/FPC 15P				< IC >	
CN713	1-774-711-41	CONNECTOR, BOARD TO BOARD 20P		IC001	8-752-090-20	IC CXA3057R-T6	
* CN715	1-778-283-11	CONNECTOR, FFC/FPC 4P (EXCEPT TR818)		IC101	8-752-093-69	IC CXA3265R-T4	
		< DIODE >		IC151	8-759-670-78	IC HG75C012SFL	
D001	8-719-421-27	DIODE MA728-(K8).SO		IC153	8-759-714-10	IC BU3095-01FV-E2	
D002	8-719-062-16	DIODE 01ZA8.2(TPL3)		IC221	8-759-599-37	IC AN2225FHQ-EB	
D004	8-719-073-03	DIODE MA8082-(K8).SO		IC271	8-752-386-72	IC CXD2444R-T4	
D005	8-719-078-02	DIODE 1SS357(T3SONY1)		IC272	8-759-699-92	IC AD80013AJSTRL	
D006	8-719-081-19	DIODE 1SS383(T5RSONY1)		IC301	8-759-637-96	IC MPC17A135DTAEL	
D007	8-719-081-19	DIODE 1SS383(T5RSONY1)		IC302	8-759-681-42	IC NJM12902V(TE2)	
D010	8-719-078-02	DIODE 1SS357(T3SONY1) (TRV49/TRV49E/TRV58/TRV58E/TRV59E/TRV68/ TRV78/TRV78E/TRV88/TRV98/TRV98E)		IC351	8-752-093-74	IC CXA3285R-T6	
D151	8-719-081-25	DIODE JDV3C11(TPH3)		IC401	8-759-593-47	IC AK6417AM-E2 (TR618/TR818/TRV49/TRV58/TRV68/TRV78/TRV88/TRV98)	
D152	8-719-081-25	DIODE JDV3C11(TPH3)		IC401	8-759-640-87	IC BR9016RFV-E2 (TR618E/TR718E/TR728E/TRV49E/ TRV58E/TRV59E/TRV78E/TRV98E)	
D271	8-719-073-01	DIODE MA111-(K8).SO (TR618/TR618E/TR718E/TR728E/TRV49/ TRV49E/TRV58/TRV58E/TRV59E)		IC402	8-759-836-63	IC MB91191RPFV-G-166-BND-ER	
D272	8-719-082-63	DIODE 1SV329(TPL3)		IC451	8-759-640-85	IC CXA8096R-TBM	
D301	8-719-073-01	DIODE MA111-(K8).SO		IC502	8-759-424-79	IC S-8423YFS-T2 (TRV49/TRV58/TRV68/TRV78/TRV78E/TRV88/TRV98/TRV98E)	
D501	8-719-421-67	DIODE MA132WK-(K8).SO		IC502	8-759-660-94	IC NJU7285AV-TE2 (TR618/TR618E/TR718E/TR728E/ TR818/TRV49E/TRV58E/TRV59E)	
D503	8-719-421-27	DIODE MA728-(K8).SO		IC503	8-752-921-65	IC CXP921048A-033R-T6	
D504	8-719-073-01	DIODE MA111-(K8).SO		IC504	8-759-653-63	IC S-817A36ANB-CUZ-T2	
D702	8-719-062-16	DIODE 01ZA8.2(TPL3)		IC601	8-759-713-19	IC BH2222FV-E2	
		< PIN CONNECTOR >				< COIL >	
ET101	1-815-032-21	PIN, CONNECTOR (CASE, SHIELD)		L001	1-416-669-11	INDUCTOR 22uH (TRV49/TRV49E/TRV58/TRV58E/TRV59E/TRV68/ TRV78/TRV78E/TRV88/TRV98/TRV98E)	
ET102	1-815-032-21	PIN, CONNECTOR (CASE, SHIELD)		L002	1-416-670-11	INDUCTOR 33uH	
		< FUSE >		L003	1-412-056-11	INDUCTOR 4.7uH (TRV49/TRV49E/TRV58/TRV58E/TRV59E/TRV68/ TRV78/TRV78E/TRV88/TRV98/TRV98E)	
△ F001	1-576-406-21	FUSE, MICRO (1.4A) (1608)		L004	1-416-669-11	INDUCTOR 22uH	
△ F002	1-576-406-21	FUSE, MICRO (1.4A) (1608)		L005	1-419-354-21	INDUCTOR 22uH	
△ F003	1-576-406-21	FUSE, MICRO (1.4A) (1608)					
△ F004	1-576-406-21	FUSE, MICRO (1.4A) (1608) (TRV49/TRV49E/TRV58/TRV58E/TRV59E/TRV68/ TRV78/TRV78E/TRV88/TRV98/TRV98E)					

Note :

The components identified by mark △ or dotted line with mark △ are critical for safety. Replace only with part number specified.

Note :

Les composants identifiés par une marque △ sont critiques pour la sécurité. Ne les remplacer que par une pièce portant le numéro spécifié.

VC-251

Ref. No.	Part No.	Description	Remarks	Ref. No.	Part No.	Description	Remarks
L006	1-416-670-11	INDUCTOR	33uH	Q023	8-729-052-65	TRANSISTOR	2SA1774HT2L
L007	1-419-354-21	INDUCTOR	22uH	Q026	8-729-053-54	TRANSISTOR	HN1A01FE-Y/GR(TPLR3)
L008	1-469-524-91	INDUCTOR	4.7uH				(TRV49/TRV49E/TRV58/TRV58E/TRV59E/TRV68/TRV78/TRV78E/TRV88/TRV98/TRV98E)
L009	1-469-524-91	INDUCTOR	4.7uH	Q027	8-729-042-28	TRANSISTOR	2SD2216J-QR(K8).SO
L010	1-469-524-91	INDUCTOR	4.7uH				(TRV49/TRV49E/TRV58/TRV58E/TRV59E/TRV68/TRV78/TRV78E/TRV88/TRV98/TRV98E)
L011	1-469-524-91	INDUCTOR	4.7uH	Q071	8-729-042-31	TRANSISTOR	UN9213J-(K8).SO
L012	1-414-400-41	INDUCTOR	22uH				(TRV49/TRV49E/TRV58/TRV58E/TRV59E/TRV68/TRV78/TRV78E/TRV88/TRV98/TRV98E)
L013	1-469-524-91	INDUCTOR	4.7uH	Q072	8-729-041-76	TRANSISTOR	NDS356AP
L014	1-469-526-91	INDUCTOR	22uH				(TRV49/TRV49E/TRV58/TRV58E/TRV59E/TRV68/TRV78/TRV78E/TRV88/TRV98/TRV98E)
L016	1-414-400-41	INDUCTOR	22uH	Q101	8-729-047-19	TRANSISTOR	2SA1965-S-TL
L101	1-414-406-41	INDUCTOR	220uH	Q102	8-729-052-65	TRANSISTOR	2SA1774HT2L
L102	1-412-952-11	INDUCTOR	12uH	Q103	8-729-054-48	TRANSISTOR	HN1B04FE-Y/GR(TPLR3)
L103	1-469-526-91	INDUCTOR	22uH	Q104	8-729-052-64	TRANSISTOR	DTC144EHT2L
L104	1-414-406-41	INDUCTOR	220uH	Q105	8-729-053-58	TRANSISTOR	RN1904FE(TPLR3)
L151	1-469-570-21	INDUCTOR	10uH	Q107	8-729-052-65	TRANSISTOR	2SA1774HT2L
L152	1-469-570-21	INDUCTOR	10uH	Q151	8-729-053-53	TRANSISTOR	HN1B04FE-Y/GR(TPLR3)
L154	1-469-570-21	INDUCTOR	10uH	Q152	8-729-042-26	TRANSISTOR	2SB1462J-QR(K8).SO
L155	1-469-570-21	INDUCTOR	10uH				(TRV49/TRV49E/TRV58/TRV58E/TRV59E/TRV68/TRV78/TRV78E/TRV88/TRV98/TRV98E)
L156	1-412-945-11	INDUCTOR	3.3uH	Q153	8-729-042-26	TRANSISTOR	2SB1462J-QR(K8).SO
L221	1-469-525-91	INDUCTOR	10uH				(TRV49/TRV49E/TRV58/TRV58E/TRV59E/TRV68/TRV78/TRV78E/TRV88/TRV98/TRV98E)
L224	1-469-525-91	INDUCTOR	10uH	Q154	8-729-042-26	TRANSISTOR	2SA1832F-Y/GR(TPL3)
L271	1-469-570-21	INDUCTOR	10uH				(TRV49/TRV49E/TRV58/TRV58E/TRV59E/TRV68/TRV78/TRV78E/TRV88/TRV98/TRV98E)
L272	1-469-525-91	INDUCTOR	10uH	Q156	8-729-052-65	TRANSISTOR	2SA1774HT2L
L301	1-469-525-91	INDUCTOR	10uH	Q158	8-729-052-65	TRANSISTOR	2SA1774HT2L
L303	1-469-570-21	INDUCTOR	10uH	Q301	8-729-052-66	TRANSISTOR	2SC4617HT2L
L601	1-469-570-21	INDUCTOR	10uH	Q302	8-729-054-51	TRANSISTOR	RN2910FE(TPLR3)
L705	1-419-860-21	INDUCTOR	10uH (EXCEPT TR818)	Q303	8-729-052-66	TRANSISTOR	2SC4617HT2L
		< TRANSISTOR >		Q352	8-729-052-63	TRANSISTOR	DTC143THT2L
Q001	8-729-038-05	TRANSISTOR	HN1K02FU(T5RSONY)				(TRV49/TRV49E/TRV58/TRV58E/TRV59E/TRV68/TRV78/TRV78E/TRV88/TRV98/TRV98E)
Q002	8-729-051-49	TRANSISTOR	TPC8305(TE12L)	Q354	8-729-053-52	TRANSISTOR	HN1C01FE-Y/GR(TPLR3)
Q003	8-729-101-07	TRANSISTOR	2SB798-T1-DLTK				(TRV49/TRV49E/TRV58/TRV58E/TRV59E/TRV68/TRV78/TRV78E/TRV88/TRV98/TRV98E)
Q004	8-729-042-31	TRANSISTOR	UN9213J-(K8).SO	Q355	8-729-053-56	TRANSISTOR	RN4990FE(TPLR3)
			(TRV49/TRV49E/TRV58/TRV58E/TRV59E/TRV68/TRV78/TRV78E/TRV88/TRV98/TRV98E)	Q451	8-729-052-66	TRANSISTOR	2SC4617HT2L
Q004	8-729-052-64	TRANSISTOR	DTC144EHT2L	Q501	8-729-041-43	TRANSISTOR	HN1L02FU(TE85R)
			(TR618/TR618E/TR718E/TR728E/TR818)	Q701	8-729-052-64	TRANSISTOR	DTC144EHT2L
Q006	8-729-054-82	TRANSISTOR	XN09D6100LS0	Q702	8-729-043-94	TRANSISTOR	CPH3106-PM-TL
			(TRV49/TRV49E/TRV58/TRV58E/TRV59E/TRV68/TRV78/TRV78E/TRV88/TRV98/TRV98E)				(EXCEPT TR818)
Q007	8-729-043-60	TRANSISTOR	CPH6102-TL	Q703	8-729-028-26	TRANSISTOR	2SK1829(TE85L)
Q008	8-729-054-82	TRANSISTOR	XN09D6100LS0				(EXCEPT TR818)
Q009	8-729-054-82	TRANSISTOR	XN09D6100LS0	Q704	8-729-903-53	TRANSISTOR	2SB1132-T1 00Q
Q010	8-729-054-82	TRANSISTOR	XN09D6100LS0	Q705	8-729-052-66	TRANSISTOR	2SC4617HT2L
Q011	8-729-054-82	TRANSISTOR	XN09D6100LS0				< RESISTOR >
Q012	8-729-054-82	TRANSISTOR	XN09D6100LS0	R001	1-216-837-11	METAL CHIP	22K 5% 1/16W
Q014	8-729-053-52	TRANSISTOR	N1C01FE-Y/GR(TPLR3)	R002	1-216-839-11	METAL CHIP	33K 5% 1/16W
Q015	8-729-101-07	TRANSISTOR	2SB798-T1-DLTK	R003	1-216-821-11	METAL CHIP	1K 5% 1/16W
Q016	8-729-042-26	TRANSISTOR	2SB1462J-QR(K8).SO	R006	1-216-837-11	METAL CHIP	22K 5% 1/16W
Q018	8-729-052-64	TRANSISTOR	DTC144EHT2L	R007	1-216-821-11	METAL CHIP	1K 5% 1/16W
Q019	8-729-053-54	TRANSISTOR	HN1A01FE-Y/GR(TPLR3)	R008	1-216-853-11	METAL CHIP	470K 5% 1/16W
Q020	8-729-053-52	TRANSISTOR	HN1C01FE-Y/GR(TPLR3)	R010	1-216-857-11	METAL CHIP	1M 5% 1/16W
			(TRV68/TRV78/TRV78E/TRV88/TRV98/TRV98E)	R011	1-216-813-11	METAL CHIP	220 5% 1/16W
Q021	8-729-052-66	TRANSISTOR	2SC4617HT2L	R012	1-216-839-11	METAL CHIP	33K 5% 1/16W
Q022	8-729-052-65	TRANSISTOR	2SC4617HT2L	R013	1-216-801-11	METAL CHIP	22 5% 1/16W

Ref. No.	Part No.	Description	Remarks	Ref. No.	Part No.	Description	Remarks
R014	1-216-829-11	METAL CHIP	4.7K 5% 1/16W	R051	1-218-891-11	METAL CHIP 68K 0.5% 1/16W	
R016	1-216-832-11	METAL CHIP	8.2K 5% 1/16W			(TRV49/TRV49E/TRV58/TRV58E/TRV59E/TRV68/ TRV78/TRV78E/TRV88/TRV98/TRV98E)	
R017	1-216-821-11	METAL CHIP	1K 5% 1/16W	R052	1-216-801-11	METAL CHIP 22 5% 1/16W	
R018	1-216-831-11	METAL CHIP	6.8K 5% 1/16W	R071	1-216-857-11	METAL CHIP 1M 5% 1/16W	
R020	1-216-833-11	METAL CHIP	10K 5% 1/16W			(TRV49/TRV49E/TRV58/TRV58E/TRV59E/TRV68/ TRV78/TRV78E/TRV88/TRV98/TRV98E)	
R021	1-216-837-11	METAL CHIP	22K 5% 1/16W	R072	1-216-857-11	METAL CHIP 1M 5% 1/16W	
			(TRV49/TRV49E/TRV58/TRV58E/TRV59E/TRV68/ TRV78/TRV78E/TRV88/TRV98/TRV98E)			(TRV49/TRV49E/TRV58/TRV58E/TRV59E/TRV68/ TRV78/TRV78E/TRV88/TRV98/TRV98E)	
R022	1-216-841-11	METAL CHIP	47K 5% 1/16W	R073	1-216-864-11	METAL CHIP 1 5% 1/16W	
R023	1-216-839-11	METAL CHIP	33K 5% 1/16W			(TR818)	
			(TRV49/TRV49E/TRV58/TRV58E/TRV59E/TRV68/ TRV78/TRV78E/TRV88/TRV98/TRV98E)	R073	1-216-864-91	SHORT 0	
R025	1-216-841-11	METAL CHIP	47K 5% 1/16W			(TR618/TR618E/TR718E/TR728E)	
R026	1-218-879-11	METAL CHIP	22K 0.5% 1/16W	R074	1-218-446-11	METAL CHIP 1 5% 1/16W	
						(TR818)	
R027	1-218-871-11	METAL CHIP	10K 0.5% 1/16W	R101	1-216-804-11	METAL CHIP 39 5% 1/16W	
R028	1-218-877-11	METAL CHIP	18K 0.5% 1/16W			(TR618E/TR718E/TR728E/TRV49E/ TRV58E/TRV59E/TRV78E/TRV98E)	
R029	1-216-829-11	METAL CHIP	4.7K 5% 1/16W	R101	1-216-806-11	RES-CHIP 56 5% 1/16W	
R031	1-216-841-11	METAL CHIP	47K 5% 1/16W			(TR618/TRV818/TRV49/TRV58/TRV68/TRV78/TRV88/TRV98)	
R032	1-216-837-11	METAL CHIP	22K 5% 1/16W	R102	1-216-818-11	METAL CHIP 560 5% 1/16W	
R033	1-218-879-11	METAL CHIP	22K 0.5% 1/16W	R105	1-216-809-11	METAL CHIP 100 5% 1/16W	
R034	1-218-871-11	METAL CHIP	10K 0.5% 1/16W	R106	1-216-838-11	METAL CHIP 27K 5% 1/16W	
R035	1-216-841-11	METAL CHIP	47K 5% 1/16W	R107	1-216-825-11	METAL CHIP 2.2K 5% 1/16W	
R036	1-216-845-11	METAL CHIP	100K 5% 1/16W	R108	1-216-829-11	METAL CHIP 4.7K 5% 1/16W	
R037	1-216-845-11	METAL CHIP	100K 5% 1/16W	R109	1-216-838-11	METAL CHIP 27K 5% 1/16W	
R038	1-216-837-11	METAL CHIP	22K 5% 1/16W	R110	1-216-813-11	METAL CHIP 220 5% 1/16W	
R039	1-216-864-91	SHORT	0	R111	1-216-813-11	METAL CHIP 220 5% 1/16W	
			(TR618/TR618E/TR718E/TR728E/TRV49/ TRV49E/TRV58/TRV58E/TRV59E)	R112	1-216-814-11	METAL CHIP 270 5% 1/16W	
R040	1-216-837-11	METAL CHIP	22K 5% 1/16W	R113	1-216-813-11	METAL CHIP 220 5% 1/16W	
R041	1-218-891-11	METAL CHIP	68K 0.5% 1/16W	R115	1-216-839-11	METAL CHIP 33K 5% 1/16W	
			(TR818/TRV68/TRV78/TRV78E/TRV88/TRV98/TRV98E)	R116	1-216-826-11	METAL CHIP 2.7K 5% 1/16W	
R041	1-218-895-11	METAL CHIP	100K 0.5% 1/16W	R117	1-216-826-11	METAL CHIP 2.7K 5% 1/16W	
			(TR618/TR618E/TR718E/TR728E/TRV49/ TRV49E/TRV58/TRV58E/TRV59E)	R118	1-218-899-11	METAL CHIP 150K 0.5% 1/16W	
R042	1-218-871-11	METAL CHIP	10K 0.5% 1/16W	R120	1-216-837-11	METAL CHIP 22K 5% 1/16W	
			(TR618/TR618E/TR718E/TR728E/TRV49/ TRV49E/TRV58/TRV58E/TRV59E)	R121	1-216-853-11	METAL CHIP 470K 5% 1/16W	
R042	1-218-879-11	METAL CHIP	22K 0.5% 1/16W	R122	1-216-853-11	METAL CHIP 470K 5% 1/16W	
			(TR818/TRV68/TRV78/TRV78E/TRV88/TRV98/TRV98E)	R123	1-216-837-11	METAL CHIP 22K 5% 1/16W	
R043	1-218-903-11	METAL CHIP	220K 0.5% 1/16W	R124	1-216-838-11	METAL CHIP 27K 5% 1/16W	
R044	1-218-895-11	METAL CHIP	100K 0.5% 1/16W	R154	1-216-833-11	METAL CHIP 10K 5% 1/16W	
			(TR818/TRV68/TRV78/TRV78E/TRV88/TRV98/TRV98E)	R155	1-216-822-11	METAL CHIP 1.2K 5% 1/16W	
R045	1-218-887-11	METAL CHIP	47K 0.5% 1/16W	R156	1-216-825-11	METAL CHIP 2.2K 5% 1/16W	
			(TR818/TRV68/TRV78/TRV78E/TRV88/TRV98/TRV98E)			(TRV49/TRV49E/TRV58/TRV58E/TRV59E/TRV68/ TRV78/TRV78E/TRV88/TRV98/TRV98E)	
R046	1-218-877-11	METAL CHIP	18K 0.5% 1/16W	R157	1-216-825-11	METAL CHIP 2.2K 5% 1/16W	
			(TR818/TRV68/TRV78/TRV78E/TRV88/TRV98/TRV98E)			(TRV49/TRV49E/TRV58/TRV58E/TRV59E/TRV68/ TRV78/TRV78E/TRV88/TRV98/TRV98E)	
R047	1-216-845-11	METAL CHIP	100K 5% 1/16W	R158	1-216-825-11	METAL CHIP 2.2K 5% 1/16W	
			(TRV49/TRV49E/TRV58/TRV58E/TRV59E/TRV68/ TRV78/TRV78E/TRV88/TRV98/TRV98E)			(TRV49/TRV49E/TRV58/TRV58E/TRV59E/ TRV68/TRV78/TRV88/TRV98)	
R048	1-216-845-11	METAL CHIP	100K 5% 1/16W	R160	1-216-825-11	METAL CHIP 2.2K 5% 1/16W	
			(TRV49/TRV49E/TRV58/TRV58E/TRV59E/TRV68/ TRV78/TRV78E/TRV88/TRV98/TRV98E)			(EXCEPT TR818)	
R049	1-216-864-91	SHORT	0	R165	1-216-864-91	SHORT 0	
			(TRV49/TRV49E/TRV58/TRV58E/TRV59E/TRV68/ TRV78/TRV78E/TRV88/TRV98/TRV98E)			(TR818)	
R050	1-218-903-11	METAL CHIP	220K 0.5% 1/16W	R166	1-216-864-91	SHORT 0	
			(TRV49/TRV49E/TRV58/TRV58E/TRV59E/TRV68/ TRV78/TRV78E/TRV88/TRV98/TRV98E)			(TR818)	
				R167	1-216-864-91	SHORT 0	
				R168	1-216-830-11	METAL CHIP 5.6K 5% 1/16W	
				R169	1-216-821-11	METAL CHIP 1K 5% 1/16W	
				R170	1-216-831-11	METAL CHIP 6.8K 5% 1/16W	

VC-251

Ref. No.	Part No.	Description	Quantity	Material	Remarks	Ref. No.	Part No.	Description	Quantity	Material	Remarks
R171	1-216-817-11	METAL CHIP	470	5%	1/16W	R280	1-216-857-11	METAL CHIP	1M	5%	1/16W
R172	1-216-809-11	METAL CHIP	100	5%	1/16W	R281	1-216-853-11	METAL CHIP	470K	5%	1/16W
R173	1-216-840-11	METAL CHIP	39K	5%	1/16W	R301	1-216-841-11	METAL CHIP	47K	5%	1/16W
R174	1-216-820-11	METAL CHIP	820	5%	1/16W	R302	1-216-821-11	METAL CHIP	1K	5%	1/16W
R175	1-216-827-11	METAL CHIP	3.3K	5%	1/16W	R304	1-216-821-11	METAL CHIP	1K	5%	1/16W
R176	1-216-832-11	METAL CHIP	8.2K	5%	1/16W	R306	1-216-797-11	METAL CHIP	10	5%	1/16W
R177	1-216-834-11	METAL CHIP	12K	5%	1/16W	R307	1-216-857-11	METAL CHIP	1M	5%	1/16W
R178	1-216-817-11	METAL CHIP	470	5%	1/16W	R308	1-216-825-11	METAL CHIP	2.2K	5%	1/16W
R179	1-216-813-11	METAL CHIP	220	5%	1/16W	R309	1-216-833-11	METAL CHIP	10K	5%	1/16W
R180	1-216-830-11	METAL CHIP	5.6K	5%	1/16W	R310	1-216-849-11	METAL CHIP	220K	5%	1/16W
R181	1-216-834-11	METAL CHIP (TRV49/TRV49E/TRV58/TRV58E/TRV59E/TRV68/ TRV78/TRV78E/TRV88/TRV98/TRV98E)	12K	5%	1/16W	R311	1-216-853-11	METAL CHIP	470K	5%	1/16W
R182	1-216-814-11	METAL CHIP (TRV49/TRV49E/TRV58/TRV58E/TRV59E/TRV68/ TRV78/TRV78E/TRV88/TRV98/TRV98E)	270	5%	1/16W	R312	1-216-853-11	METAL CHIP	470K	5%	1/16W
R183	1-216-814-11	METAL CHIP (TRV49/TRV49E/TRV58/TRV58E/TRV59E/TRV68/ TRV78/TRV78E/TRV88/TRV98/TRV98E)	270	5%	1/16W	R313	1-216-825-11	METAL CHIP	2.2K	5%	1/16W
R184	1-216-834-11	METAL CHIP (TRV49/TRV49E/TRV58/TRV58E/TRV59E/TRV68/ TRV78/TRV78E/TRV88/TRV98/TRV98E)	12K	5%	1/16W	R314	1-216-835-11	METAL CHIP	15K	5%	1/16W
R185	1-216-834-11	METAL CHIP (TRV49/TRV49E/TRV58/TRV58E/TRV59E/TRV68/ TRV78/TRV78E/TRV88/TRV98/TRV98E)	12K	5%	1/16W	R316	1-216-853-11	METAL CHIP	470K	5%	1/16W
R186	1-216-814-11	METAL CHIP (TRV49/TRV49E/TRV58/TRV58E/TRV59E/TRV68/ TRV78/TRV78E/TRV88/TRV98/TRV98E)	270	5%	1/16W	R317	1-216-821-11	METAL CHIP	1K	5%	1/16W
R187	1-216-814-11	METAL CHIP (TR818)	270	5%	1/16W	R318	1-216-821-11	METAL CHIP	1K	5%	1/16W
R188	1-216-834-11	METAL CHIP	12K	5%	1/16W	R319	1-216-815-11	METAL CHIP	330	5%	1/16W
R189	1-216-833-11	METAL CHIP (EXCEPT TR818)	10K	5%	1/16W	R321	1-216-821-11	METAL CHIP	1K	5%	1/16W
R189	1-216-834-11	METAL CHIP (TR818)	12K	5%	1/16W	R322	1-216-833-11	METAL CHIP	10K	5%	1/16W
R190	1-216-814-11	METAL CHIP (TR818)	270	5%	1/16W	R323	1-216-841-11	METAL CHIP	47K	5%	1/16W
R190	1-216-817-11	METAL CHIP (EXCEPT TR818)	470	5%	1/16W	R351	1-216-821-11	METAL CHIP	1K	5%	1/16W
R191	1-216-814-11	METAL CHIP (TR818)	270	5%	1/16W	R353	1-216-864-91	SHORT	0		
R192	1-216-834-11	METAL CHIP	12K	5%	1/16W			(TR818/TR618/TR618E/TR718E/TR728E)			
R193	1-216-857-11	METAL CHIP	1M	5%	1/16W	R354	1-216-809-11	METAL CHIP (TR818/TRV49/TRV49E/TRV58/TRV58E/TRV59E/ TRV68/TRV78/TRV78E/TRV88/TRV98/TRV98E)	100	5%	1/16W
R195	1-216-835-11	METAL CHIP	15K	5%	1/16W	R356	1-216-864-91	SHORT (TRV49/TRV49E/TRV58/TRV58E/TRV59E/TRV68/ TRV78/TRV78E/TRV88/TRV98/TRV98E)	0		
R196	1-216-835-11	METAL CHIP	15K	5%	1/16W	R358	1-216-833-11	METAL CHIP (TR818/TRV49/TRV49E/TRV58/TRV58E/TRV59E/ TRV68/TRV78/TRV78E/TRV88/TRV98/TRV98E)	10K	5%	1/16W
R197	1-216-834-11	METAL CHIP	12K	5%	1/16W	R363	1-216-832-11	METAL CHIP (TRV49/TRV49E/TRV58/TRV58E/TRV59E/TRV68/ TRV78/TRV78E/TRV88/TRV98/TRV98E)	8.2K	5%	1/16W
R198	1-216-817-11	METAL CHIP	470	5%	1/16W	R364	1-216-845-11	METAL CHIP (TRV49/TRV49E/TRV58/TRV58E/TRV59E/TRV68/ TRV78/TRV78E/TRV88/TRV98/TRV98E)	100K	5%	1/16W
R199	1-216-821-11	METAL CHIP	1K	5%	1/16W	R368	1-216-847-11	METAL CHIP	150K	5%	1/16W
R200	1-216-833-11	METAL CHIP	10K	5%	1/16W	R372	1-216-841-11	METAL CHIP	47K	5%	1/16W
R204	1-216-825-11	METAL CHIP	2.2K	5%	1/16W	R373	1-216-853-11	METAL CHIP	470K	5%	1/16W
R208	1-216-864-91	SHORT	0			R379	1-216-820-11	METAL CHIP	820	5%	1/16W
R216	1-216-807-11	METAL CHIP	68	5%	1/16W	R382	1-216-841-11	METAL CHIP	47K	5%	1/16W
R226	1-216-864-91	SHORT	0			R401	1-216-821-11	METAL CHIP	1K	5%	1/16W
R229	1-216-807-11	METAL CHIP	68	5%	1/16W	R402	1-216-854-11	METAL CHIP	560K	5%	1/16W
R232	1-218-879-11	METAL CHIP	22K	0.5%	1/16W	R403	1-216-845-11	METAL CHIP	100K	5%	1/16W
R271	1-216-845-11	METAL CHIP (TR618/TR618E/TR718E/TR728E/TRV49/ TRV49E/TRV58/TRV58E/TRV59E)	100K	5%	1/16W	R404	1-216-845-11	METAL CHIP	100K	5%	1/16W
R274	1-216-845-11	METAL CHIP	100K	5%	1/16W	R408	1-216-845-11	METAL CHIP	100K	5%	1/16W
R275	1-216-864-91	SHORT (TR818/TRV68/TRV78/TRV78E/TRV88/TRV98/TRV98E)	0			R411	1-216-845-11	METAL CHIP	100K	5%	1/16W
						R417	1-216-825-11	METAL CHIP	2.2K	5%	1/16W
						R420	1-216-841-11	METAL CHIP	47K	5%	1/16W
						R428	1-216-845-11	METAL CHIP	100K	5%	1/16W
						R431	1-218-881-11	METAL CHIP	27K	0.5%	1/16W
						R432	1-218-895-11	METAL CHIP	100K	0.5%	1/16W
						R433	1-216-845-11	METAL CHIP	100K	5%	1/16W
						R434	1-216-864-91	SHORT	0		
						R451	1-216-841-11	METAL CHIP	47K	5%	1/16W
						R452	1-216-851-11	METAL CHIP	330K	5%	1/16W
						R455	1-216-845-11	METAL CHIP	100K	5%	1/16W
						R457	1-216-817-11	METAL CHIP	470	5%	1/16W

Ref. No.	Part No.	Description	Remarks	Ref. No.	Part No.	Description	Remarks
R458	1-217-671-11	METAL CHIP	1 5% 1/10W	R613	1-216-833-11	METAL CHIP 10K 5% 1/16W	(TR618/TR618E/TR718E/TR728E)
R459	1-217-671-11	METAL CHIP	1 5% 1/10W	R613	1-216-837-11	METAL CHIP 22K 5% 1/16W	(TR818/TRV78E/TRV98E)
R460	1-217-671-11	METAL CHIP	1 5% 1/10W	R613	1-216-845-11	METAL CHIP 100K 5% 1/16W	(TRV49/TRV49E/TRV58/TRV58E/TRV59E/TRV68/TRV78/TRV88/TRV98)
R461	1-216-812-11	METAL CHIP	180 5% 1/16W	R614	1-216-837-11	METAL CHIP 22K 5% 1/16W	(TRV49/TRV49E/TRV58/TRV58E/TRV59E/TRV68/TRV78/TRV78E/TRV88/TRV98E)
R462	1-216-811-11	METAL CHIP	150 5% 1/16W	R614	1-216-845-11	METAL CHIP 100K 5% 1/16W	(TR818)
R464	1-216-817-11	METAL CHIP	470 5% 1/16W	R701	1-216-821-11	METAL CHIP 1K 5% 1/16W	(EXCEPT TR818)
R465	1-216-829-11	METAL CHIP	4.7K 5% 1/16W	R702	1-216-813-11	METAL CHIP 220 5% 1/16W	(EXCEPT TR818)
R466	1-216-833-11	METAL CHIP	10K 5% 1/16W	R703	1-216-845-11	METAL CHIP 100K 5% 1/16W	(EXCEPT TR818)
R466	1-216-864-91	SHORT	0	R704	1-216-795-11	RES-CHIP 6.8 5% 1/16W	
R467	1-216-835-11	METAL CHIP	15K 5% 1/16W	R705	1-216-830-11	METAL CHIP 5.6K 5% 1/16W	
R467	1-216-841-11	METAL CHIP	47K 5% 1/16W	R706	1-216-821-11	METAL CHIP 1K 5% 1/16W	
R468	1-216-827-11	METAL CHIP	3.3K 5% 1/16W	R707	1-216-837-11	METAL CHIP 22K 5% 1/16W	
R469	1-216-845-11	METAL CHIP	100K 5% 1/16W	R708	1-216-795-11	RES-CHIP 6.8 5% 1/16W	
R470	1-216-833-11	METAL CHIP	10K 5% 1/16W	R709	1-216-821-11	METAL CHIP 1K 5% 1/16W	(TR818)
R470	1-216-864-91	SHORT	0	R710	1-216-821-11	METAL CHIP 1K 5% 1/16W	(TR818)
R471	1-218-446-11	METAL CHIP	1 5% 1/16W	R711	1-216-813-11	METAL CHIP 220 5% 1/16W	(TRV68/TRV78/TRV88/TRV98)
R472	1-218-446-11	METAL CHIP	1 5% 1/16W	R712	1-216-813-11	METAL CHIP 220 5% 1/16W	(TRV68/TRV78/TRV88/TRV98)
R474	1-216-841-11	METAL CHIP	47K 5% 1/16W	R713	1-216-813-11	METAL CHIP 220 5% 1/16W	(TR818/TRV49/TRV49E/TRV58/TRV58E/TRV59E/TRV68/TRV78/TRV78E/TRV88/TRV98E)
R480	1-216-835-11	METAL CHIP	15K 5% 1/16W	R916	1-218-881-11	METAL CHIP 27K 0.5% 1/16W	
R480	1-216-841-11	METAL CHIP	47K 5% 1/16W	R917	1-218-893-11	METAL CHIP 82K 0.5% 1/16W	
R481	1-216-829-11	METAL CHIP	4.7K 5% 1/16W	< COMPOSITION CIRCUIT BLOCK >			
R501	1-216-845-11	METAL CHIP	100K 5% 1/16W	RB101	1-239-702-81	RESISTOR, NETWORK 22K	
R502	1-216-864-91	SHORT	0	RB102	1-239-698-11	RESISTOR, NETWORK 10K	
R504	1-216-845-11	METAL CHIP	100K 5% 1/16W	RB151	1-239-698-11	RESISTOR, NETWORK 10K	
R513	1-216-841-11	METAL CHIP	47K 5% 1/16W	RB221	1-239-686-11	RESISTOR, NETWORK 1K	
R516	1-216-857-11	METAL CHIP	1M 5% 1/16W	RB222	1-239-686-11	RESISTOR, NETWORK 1K	
R519	1-218-903-11	METAL CHIP	220K 0.5% 1/16W	RB223	1-239-672-81	RESISTOR, NETWORK 68	
R520	1-218-911-11	METAL CHIP	470K 0.5% 1/16W	RB272	1-234-380-21	RES, NETWORK 47KX4 (1005)	
R521	1-218-911-11	METAL CHIP	470K 0.5% 1/16W	RB273	1-234-372-21	RES, NETWORK 100X4 (1005)	
R525	1-216-821-11	METAL CHIP	1K 5% 1/16W	RB301	1-239-708-81	RESISTOR, NETWORK 68K	
R531	1-216-833-11	METAL CHIP	10K 5% 1/16W	RB302	1-239-702-81	RESISTOR, NETWORK 22K	
R542	1-216-841-11	METAL CHIP	47K 5% 1/16W	RB351	1-239-698-11	RESISTOR, NETWORK 10K	(TRV49/TRV49E/TRV58/TRV58E/TRV59E/TRV68/TRV78/TRV78E/TRV88/TRV98E)
R543	1-216-854-11	METAL CHIP	560K 5% 1/16W	RB352	1-239-706-81	RESISTOR, NETWORK 47K	(TRV49/TRV49E/TRV58/TRV58E/TRV59E/TRV68/TRV78/TRV78E/TRV88/TRV98E)
R544	1-216-821-11	METAL CHIP	1K 5% 1/16W	RB401	1-234-381-21	RES, NETWORK 100KX4 (1005)	
R547	1-216-857-11	METAL CHIP	1M 5% 1/16W	RB402	1-239-694-81	RESISTOR, NETWORK 4.7K	
R552	1-219-570-11	RES-CHIP	10M 5% 1/16W	RB406	1-239-698-11	RESISTOR, NETWORK 10K	
R554	1-216-845-11	METAL CHIP	100K 5% 1/16W	RB407	1-239-690-81	RESISTOR, NETWORK 2.2K	
R558	1-216-817-11	METAL CHIP	470 5% 1/16W	RB451	1-234-381-21	RES, NETWORK 100KX4 (1005)	
R559	1-216-803-11	METAL CHIP	33 5% 1/16W	RB452	1-239-698-11	RESISTOR, NETWORK 10K	
R611	1-216-833-11	METAL CHIP	10K 5% 1/16W	RB501	1-234-375-21	RES, NETWORK 1KX4 (1005)	
R611	1-216-837-11	METAL CHIP	22K 5% 1/16W	RB502	1-234-383-21	RES, NETWORK 470KX4 (1005)	
R611	1-216-845-11	METAL CHIP	100K 5% 1/16W				
R612	1-216-833-11	METAL CHIP	10K 5% 1/16W				
R612	1-216-837-11	METAL CHIP	22K 5% 1/16W				
R612	1-216-845-11	METAL CHIP	100K 5% 1/16W				

Ref. No.	Part No.	Description	Remarks	Ref. No.	Part No.	Description	Remarks
RB503	1-234-383-21	RES, NETWORK 470KX4 (1005)				< DIODE >	
RB504	1-234-375-21	RES, NETWORK 1KX4 (1005)					
RB505	1-239-686-11	RESISTOR, NETWORK 1K		D901	8-719-951-21	DIODE PR1102W-TR	
RB506	1-234-378-21	RES, NETWORK 10KX4 (1005) (TR618/TR618E/TR718E/TR728E/TR818)		D903	8-719-073-01	DIODE MA111-(K8).S0	
RB508	1-239-686-11	RESISTOR, NETWORK 1K				< IC >	
RB509	1-239-657-81	RESISTOR, NETWORK 470K		IC901	8-759-196-14	IC BA7149F-E2	
RB510	1-234-375-21	RES, NETWORK 1KX4 (1005)				< COIL >	
RB511	1-234-383-21	RES, NETWORK 470KX4 (1005)		L901	1-412-031-11	INDUCTOR CHIP 47uH	
RB514	1-239-706-81	RESISTOR, NETWORK 47K		L902	1-410-387-11	INDUCTOR CHIP 33uH	
		< TRANSFORMER >		△L903	1-411-697-11	COIL, FERRITE (HLC)	
T001	1-435-252-11	TRANSFORMER, DC-DC CONVERTER				< TRANSISTOR >	
		< VARISTOR >		Q901	8-729-230-63	TRANSISTOR 2SD1819A-QRS-TX	
VDR701	1-803-974-21	VARISTOR, CHIP		Q902	8-729-106-68	TRANSISTOR 2SD1615-T1GLGK	
VDR703	1-803-974-21	VARISTOR, CHIP		Q903	8-729-216-31	TRANSISTOR 2SA1163G-TE85L	
VDR704	1-803-974-21	VARISTOR, CHIP		Q904	8-729-230-63	TRANSISTOR 2SD1819A-QRS-TX	
VDR706	1-803-974-21	VARISTOR, CHIP				< RESISTOR >	
VDR707	1-803-974-21	VARISTOR, CHIP		R901	1-216-817-11	METAL CHIP 470	5% 1/16W
		< VIBRATOR >		R902	1-216-817-11	METAL CHIP 470	5% 1/16W
X271	1-760-320-11	VIBRATOR, CRYSTAL (28.636363MHz) (TR618/TR818/TRV49/TRV58/TRV68/TRV78/TRV88/TRV98)		R903	1-216-055-00	METAL CHIP 1.8K	5% 1/10W
X271	1-760-321-11	VIBRATOR, CRYSTAL (28.375MHz) (TR618E/TR718E/TR728E/TRV49E/ TRV58E/TRV59E/TRV78E/TRV98E)		R904	1-216-833-11	METAL CHIP 10K	5% 1/16W
X401	1-760-655-41	VIBRATOR, CRYSTAL (20MHz)		R905	1-216-822-11	METAL CHIP 1.2K	5% 1/16W
X501	1-767-980-21	VIBRATOR, CERAMIC (20MHz)		R906	1-216-823-11	METAL CHIP 1.5K	5% 1/16W
X502	1-760-458-21	VIBRATOR, CRYSTAL (32.768kHz)		R907	1-216-845-11	METAL CHIP 100K	5% 1/16W
				R908	1-216-852-11	METAL CHIP 390K	5% 1/16W
				R909	1-216-833-11	METAL CHIP 10K	5% 1/16W
				R910	1-216-835-11	METAL CHIP 15K	5% 1/16W
				R911	1-216-160-00	RES-CHIP 27	5% 1/8W
A-7073-838-A	VF-129 (N) BOARD, COMPLETE (EXCEPT TR818)			R912	1-216-857-11	METAL CHIP 1M	5% 1/16W
	***** (Ref.No.:1000 Series)			R915	1-218-879-11	METAL CHIP 22K	0.5% 1/16W
				R917	1-218-891-11	METAL CHIP 68K	0.5% 1/16W
				R918	1-216-829-11	METAL CHIP 4.7K	5% 1/16W
		< CAPACITOR >		R919	1-216-843-11	METAL CHIP 68K	5% 1/16W
C901	1-107-854-11	TANTAL. CHIP 68uF 20% 6.3V		R920	1-216-837-11	METAL CHIP 22K	5% 1/16W
C902	1-163-038-11	CERAMIC CHIP 0.1uF 25V		R921	1-216-795-11	RES-CHIP 6.8	5% 1/16W
C903	1-135-145-11	TANTALUM CHIP 0.47uF 10% 35V		R921	1-216-800-11	RES-CHIP 18	5% 1/16W
C904	1-162-965-11	CERAMIC CHIP 0.0015uF 10% 50V		R922	1-216-850-11	METAL CHIP 270K	5% 1/16W
C905	1-104-752-11	TANTAL. CHIP 33uF 20% 6.3V		R923	1-216-857-11	METAL CHIP 1M	5% 1/16W
C906	1-162-638-11	CERAMIC CHIP 1uF 16V		R924	1-216-862-11	RES-CHIP 2.7M	5% 1/16W
C907	1-104-563-11	FILM CHIP 0.1uF 5% 16V		R925	1-216-862-11	RES-CHIP 2.7M	5% 1/16W
C908	1-162-920-11	CERAMIC CHIP 27PF 5% 50V		R926	1-216-821-11	METAL CHIP 1K	5% 1/16W
C909	1-163-009-11	CERAMIC CHIP 0.001uF 10% 50V		R927	1-216-821-11	METAL CHIP 1K	5% 1/16W
△C910	1-162-625-11	CERAMIC CHIP 0.0047uF 5% 50V		R928	1-216-827-11	METAL CHIP 3.3K	5% 1/16W
△C911	1-164-715-11	CERAMIC CHIP 0.0068uF 5% 50V		R929	1-216-821-11	METAL CHIP 1K	5% 1/16W
C912	1-107-854-11	TANTAL. CHIP 68uF 20% 6.3V		R930	1-216-791-11	METAL CHIP 3.3	5% 1/16W
C913	1-135-145-11	TANTALUM CHIP 0.47uF 10% 35V		R931	1-217-671-11	METAL CHIP 1	5% 1/10W
C914	1-113-984-11	TANTAL. CHIP 1.5uF 20% 35V		R932	1-216-829-11	METAL CHIP 4.7K	5% 1/16W
C915	1-163-037-11	CERAMIC CHIP 0.022uF 10% 25V				< VARIABLE RESISTOR >	
C916	1-135-475-91	CERAMIC CHIP 0.001uF 10% 630V		RV903	1-238-852-11	RES, ADJ, CERMET 470	
		< CONNECTOR >		RV904	1-238-095-11	RES, ADJ, CERMET 470K	
* CN901	1-785-379-01	CONNECTOR, FFC/FPC 4P					
* CN902	1-580-057-11	PIN, CONNECTOR (SMD) 4P					

Note :

The components identified by mark △ or dotted line with mark △ are critical for safety. Replace only with part number specified.

Note :

Les composants identifiés par une marque △ sont critiques pour la sécurité. Ne les remplacer que par une pièce portant le numéro spécifié.

Ref. No.	Part No.	Description	Remarks
		< TRANSFORMER >	
△ T901	1-453-124-11	TRANSFORMER ASSY, FLYBACK	
T902	1-431-915-11	TRANSFORMER ASSY, FLYBACK (M)	
		< FLAT CABLE >	
△ W901	1-540-019-21	SOCKET ASSY, CRT	
	A-7074-193-A	VF-141 BOARD, COMPLETE (TR818) ***** (Ref.No.;10000 Series)	
		< CAPACITOR >	
C4501	1-127-688-21	TANTAL. CHIP 10uF 20% 6.3V	
C4501	1-135-259-11	TANTAL. CHIP 10uF 20% 6.3V	
C4503	1-107-826-11	CERAMIC CHIP 0.1uF 10% 16V	
C4504	1-107-826-11	CERAMIC CHIP 0.1uF 10% 16V	
C4507	1-162-970-11	CERAMIC CHIP 0.01uF 10% 25V	
C4508	1-162-970-11	CERAMIC CHIP 0.01uF 10% 25V	
C4509	1-162-970-11	CERAMIC CHIP 0.01uF 10% 25V	
C4510	1-107-826-11	CERAMIC CHIP 0.1uF 10% 16V	
C4511	1-164-739-11	CERAMIC CHIP 560PF 5% 50V	
C4512	1-107-826-11	CERAMIC CHIP 0.1uF 10% 16V	
C4513	1-107-826-11	CERAMIC CHIP 0.1uF 10% 16V	
C4514	1-107-687-11	TANTAL. CHIP 3.3uF 20% 20V	
C4515	1-164-357-11	CERAMIC CHIP 0.001uF 5% 50V	
C4516	1-162-928-11	CERAMIC CHIP 120PF 5% 50V	
C4517	1-107-826-11	CERAMIC CHIP 0.1uF 10% 16V	
C4518	1-109-982-11	CERAMIC CHIP 1uF 10% 10V	
C4519	1-109-982-11	CERAMIC CHIP 1uF 10% 10V	
C4520	1-109-982-11	CERAMIC CHIP 1uF 10% 10V	
C4521	1-107-826-11	CERAMIC CHIP 0.1uF 10% 16V	
C4523	1-115-566-11	CERAMIC CHIP 4.7uF 10% 10V	
C4524	1-164-505-11	CERAMIC CHIP 2.2uF 16V	
C4526	1-107-726-11	CERAMIC CHIP 0.01uF 10% 25V	
C4527	1-107-725-11	CERAMIC CHIP 0.1uF 10% 16V	
		< CONNECTOR >	
CN4501	1-764-526-11	CONNECTOR, FFC/FPC 18P	
CN4502	1-750-630-11	CONNECTOR, FFC/FPC (ZIF) 16P	
		< DIODE >	
D4502	8-713-102-80	DIODE 1T369-01-T8A	
D4503	8-719-077-74	DIODE MA2S784008S0	
D4504	8-719-077-74	DIODE MA2S784008S0	
		< FERRITE BEAD >	
FB4502	1-500-329-21	FERRITE 0UH	
FB4505	1-500-329-21	FERRITE 0UH	
		< IC >	
IC4501	8-759-660-93	IC RB5P004AM1	
IC4502	8-752-405-57	IC CXD3501AR-T4	

Ref. No.	Part No.	Description	Remarks
		< COIL >	
L4501	1-469-525-91	INDUCTOR 10uH	
L4504	1-412-949-21	INDUCTOR 6.8uH	
		< TRANSISTOR >	
Q4504	8-729-037-52	TRANSISTOR 2SD2216J-QR(K8).SO	
		< RESISTOR >	
R4505	1-216-853-11	METAL CHIP 470K 5% 1/16W	
R4507	1-218-895-11	METAL CHIP 100K 0.5% 1/16W	
R4508	1-216-845-11	METAL CHIP 100K 5% 1/16W	
R4513	1-216-835-11	METAL CHIP 15K 5% 1/16W	
R4515	1-216-826-11	METAL CHIP 2.7K 5% 1/16W	
R4516	1-216-841-11	METAL CHIP 47K 5% 1/16W	
R4517	1-216-843-11	METAL CHIP 68K 5% 1/16W	
R4518	1-216-837-11	METAL CHIP 22K 5% 1/16W	
R4520	1-216-843-11	METAL CHIP 68K 5% 1/16W	
R4521	1-216-857-11	METAL CHIP 1M 5% 1/16W	
R4522	1-216-845-11	METAL CHIP 100K 5% 1/16W	
R4523	1-216-845-11	METAL CHIP 100K 5% 1/16W	
R4524	1-216-844-11	METAL CHIP 82K 5% 1/16W	
R4525	1-216-838-11	METAL CHIP 27K 5% 1/16W	
R4526	1-216-809-11	METAL CHIP 100 5% 1/16W	
R4527	1-216-809-11	METAL CHIP 100 5% 1/16W	
R4528	1-216-809-11	METAL CHIP 100 5% 1/16W	
R4529	1-216-833-11	METAL CHIP 10K 5% 1/16W	
R4530	1-216-845-11	METAL CHIP 100K 5% 1/16W	
R4534	1-216-864-91	SHORT 0	
R4542	1-216-864-91	SHORT 0	
R4544	1-216-853-11	METAL CHIP 470K 5% 1/16W	
R4545	1-216-845-11	METAL CHIP 100K 5% 1/16W	
R4546	1-216-845-11	METAL CHIP 100K 5% 1/16W	
R4547	1-216-845-11	METAL CHIP 100K 5% 1/16W	
		ACCESSORIES *****	
	1-467-574-21	REMOTE COMMANDER (RMT-708) (TR728E/TRV49/TRV49E/TRV59E/ TRV78/TRV78E/TRV98/TRV98E)	
	1-467-574-73	REMOTE COMMANDER (RMT-708) (TRV49E:E/TRV78E:E/TRV98E:E)	
△	1-475-599-11	ADAPTOR, AC (AC-L10A) (TR618/TR618E:E,HK,AUS/TR718E:AEP,UK/TR728E:AEP,UK/ TR818/TRV49:E,HK,JE/TRV49E:E,HK,AUS,JE/TRV58/ TRV58E/TRV59E/TRV68/TRV78:E,HK,JE/TRV78E/TRV88/ TRV98:US,CND,E,HK,JE,BR/TRV98E:AEP,UK,E,HK,AUS,JE)	
△	1-475-599-71	ADAPTOR, AC (AC-L10A) (TRV49:KR/TRV78:KR/TRV98:KR)	
△	1-475-599-81	ADAPTOR, AC (AC-L10B) (TR618E:CN/TRV49E:CN/TRV98E:CN)	

<p>Note : The components identified by mark △ or dotted line with mark △ are critical for safety. Replace only with part number specified.</p>	<p>Note : Les composants identifiés par une marque △ sont critiques pour la sécurité. Ne les remplacer que par une pièce portant le numéro spécifié.</p>
---	---

Ref. No.	Part No.	Description	Remarks	Ref. No.	Part No.	Description	Remarks
△	1-569-007-11	ADAPTOR, CONVERSION 2P (TRV49:JE/TRV49E:JE/TRV78:JE/TRV78E:JE/ TRV98:JE/TRV98E:JE)			3-065-646-61	MANUAL, INSTRUCTION (ENGLISH/SWEDISH) (TR718E:AEP/TR728E:AEP)	
△	1-569-008-21	ADAPTOR, CONVERSION 2P (TR618/TR618E:E,HK/TR818:E, BR/TRV49:E,HK/ TRV49E:E,HK/TRV58:E, BR/TRV68:E/TRV78:E,HK/ TRV78E:E,HK/TRV88:E/TRV98:E,HK/TRV98E:E,HK)			3-065-646-71	MANUAL, INSTRUCTION (FINNISH/DANISH) (TR718E:AEP/TR728E:AEP)	
	1-573-291-11	ADAPTOR, CONVERSION 21P (TR718E/TR728E/TRV58E/TRV59E/ TRV78E:AEP,UK/TRV98E:AEP,UK)			3-065-646-81	MANUAL, INSTRUCTION (POLISH/CZECH) (TR718E:AEP/TR728E:AEP)	
* △	1-575-131-11	CORD, POWER (TR818:E, BR/TRV49:E/TRV49E:E/TRV58:E, BR/TRV68:E/ TRV78:E/TRV78E:E/TRV88:E/TRV98:E, BR/TRV98E:E)			3-065-646-91	MANUAL, INSTRUCTION (SLOVAKIAN) (TR718E:AEP/TR728E:AEP)	
△	1-690-827-11	CORD SET, POWER (TR718E:AEP/TR728E:AEP/TRV58E:AEP/ TRV59E:AEP/TRV78E:AEP/TRV98E:AEP)			3-065-647-11	MANUAL, INSTRUCTION (ARABIC/PERSIAN) (TR618E:E)	
△	1-696-819-11	CORD, POWER (TR618E:AUS/TRV49E:AUS/TRV78E:AUS/TRV98E:AUS)			3-065-647-21	MANUAL, INSTRUCTION (SIMPLIFIED CHINESE) (TR618E:E,CN)	
△	1-769-608-11	CORD, POWER (TR618/TR618E:E/TR818:E/TRV49:E/TRV49E:E/TRV58:E/ TRV68:E/TRV78:E/TRV78E:E/TRV88:E/TRV98:E/TRV98E:E)			3-065-647-31	MANUAL, INSTRUCTION (TRADITIONAL CHINESE) (TR618E:HK)	
△	1-775-843-21	CORD, POWER (WITH FILTER) (TR718E:UK/TR728E:UK/TRV58E:UK/ TRV59E:UK/TRV78E:UK/TRV98E:UK)			3-065-648-11	MANUAL, INSTRUCTION (ENGLISH) (TRV49:E, HK, JE/TRV58/TRV68/TRV78:E, HK, JE/ TRV88/TRV98:US, CND, E, HK, JE)	
△	1-776-985-11	CORD, POWER (TRV49:KR/TRV78:KR/TRV98:KR)			3-065-648-21	MANUAL, INSTRUCTION (FRENCH) (TRV58:CND/TRV68:CND/TRV98:CND)	
△	1-782-476-11	CORD, POWER (TR618E:CN/TRV49E:CN/TRV98E:CN)			3-065-648-31	MANUAL, INSTRUCTION (SPANISH/PORTUGUESE) (TRV49:E, JE/TRV58:E, AR/ TRV68:E/TRV78:E, JE/TRV88:E/TRV98:E, JE)	
△	1-783-374-11	CORD, POWER (TR618E:HK/TRV49:HK/TRV49E:HK/TRV78:HK/ TRV78E:HK/TRV98:HK/TRV98E:HK)			3-065-648-41	MANUAL, INSTRUCTION (TRADITIONAL CHINESE) (TRV49:E, HK/TRV78:E, HK/TRV98:E, HK)	
△	1-783-952-11	CORD, POWER (TR818:AR/TRV58:AR)			3-065-648-51	MANUAL, INSTRUCTION (KOREAN) (TRV49:KR, JE/TRV78:KR, JE/TRV98:KR, JE)	
△	1-783-738-31	CORD, CONNECTION (AV CABLE)(1.5m)			3-065-648-61	MANUAL, INSTRUCTION (ARABIC) (TRV49:E/TRV78:E/TRV98:E)	
△	1-790-107-22	CORD, POWER (TR818:US, CND/TRV58:US, CND/TRV68:US, CND/ TRV88:US/TRV98:US, CND)			3-065-649-11	MANUAL, INSTRUCTION (ENGLISH/RUSSIAN) (TRV49E/TRV58E:AEP/TRV59E:AEP, E, HK, AUS, JE/ TRV98E:AEP, E, HK, AUS, JE, CN)	
△	1-790-732-11	CORD, POWER (TRV49:JE/TRV49E:JE/TRV78:JE/TRV78E:JE/ TRV98:JE/TRV98E:JE)			3-065-649-21	MANUAL, INSTRUCTION (FRENCH/GERMAN) (TRV49E:E, JE/TRV58E:AEP/TRV59E:AEP/ TRV78E:AEP, JE/TRV98E:AEP, JE)	
	3-065-645-11	MANUAL, INSTRUCTION (ENGLISH) (TR618/TR818:US, CND)			3-065-649-31	MANUAL, INSTRUCTION (ENGLISH/DUTCH) (TRV58E:AEP/TRV59E:AEP/TRV78E:AEP/TRV98E:AEP)	
	3-065-645-21	MANUAL, INSTRUCTION (FRENCH) (TR818:CND)			3-065-649-41	MANUAL, INSTRUCTION (SPANISH/PORTUGUESE) (TRV58E:AEP/TRV59E:AEP/ TRV78E:AEP/TRV98E:AEP)	
	3-065-645-31	MANUAL, INSTRUCTION (SPANISH/PORTUGUESE) (TR618/TR818:E, AR)			3-065-649-51	MANUAL, INSTRUCTION (ITALIAN/GREEK) (TRV58E:AEP/TRV59E:AEP1/TRV78E:AEP/TRV98E:AEP)	
	3-065-645-41	MANUAL, INSTRUCTION (TRANDITIONAL CHINESE) (TR618)			3-065-649-61	MANUAL, INSTRUCTION (ENGLISH/SWEDISH) (TRV58E:AEP/TRV59E:AEP/TRV78E:AEP/TRV98E:AEP)	
	3-065-645-61	MANUAL, INSTRUCTION (ARABIC) (TR618)			3-065-649-71	MANUAL, INSTRUCTION (FINNISH/DANISH) (TRV58E:AEP/TRV59E:AEP/TRV78E:AEP/TRV98E:AEP)	
	3-065-646-11	MANUAL, INSTRUCTION (ENGLISH/RUSSIAN) (TR618E/TR718E:AEP/TR728E:AEP)			3-065-649-81	MANUAL, INSTRUCTION (POLISH/CZECH) (TRV58E:AEP/TRV59E:AEP/TRV78E:AEP/TRV98E:AEP)	
	3-065-646-21	MANUAL, INSTRUCTION (FRENCH/GERMAN) (TR618E:E/TR718E:AEP/TR728E:AEP)			3-065-649-91	MANUAL, INSTRUCTION (SLOVAKIAN/HUNGARIAN) (TRV58E:AEP/TRV59E:AEP/ TRV78E:AEP/TRV98E:AEP)	
	3-065-646-31	MANUAL, INSTRUCTION (ENGLISH/DUTCH) (TR718E:AEP/TR728E:AEP)			3-065-650-11	MANUAL, INSTRUCTION (ARABIC/PERSIAN) (TRV49E:E/TRV78E:E/TRV98E:E)	
	3-065-646-41	MANUAL, INSTRUCTION (SPANISH/PORTUGUESE) (TR718E:AEP/TR728E:AEP)			3-065-650-21	MANUAL, INSTRUCTION (SIMPLIFIED CHINESE) (TRV49E:E, JE, CN/TRV78E:E, JE/TRV98E:E, JE, CN)	
	3-065-646-51	MANUAL, INSTRUCTION (ITALIAN/GREEK) (TR718E:AEP/TR728E:AEP)			3-065-650-31	MANUAL, INSTRUCTION (TRANDITIONAL CHINESE) (TRV49E:HK/TRV78E:HK/TRV98E:HK)	
					3-958-131-01	LID, BATTERY CASE (FOR RMT-708)	

Note :
The components identified by mark △ or dotted line with mark △ are critical for safety. Replace only with part number specified.

Note :
Les composants identifiés par une marque △ sont critiques pour la sécurité. Ne les remplacer que par une pièce portant le numéro spécifié.

〈FOR CAMERA COLOR REPRODUCTION ADJUSTMENT〉

For NTSC model

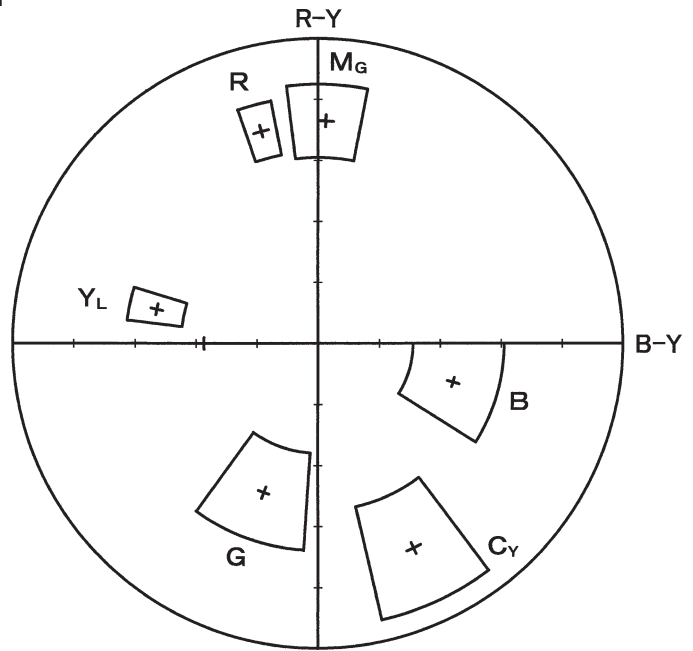

CCD-TR618/TR818/TRV49/TRV58/
TRV68/TRV78/TRV88/TRV98

Take a copy of CAMERA COLOR
REPRODUCTION FRAME with
a clear sheet for use.



For PAL model

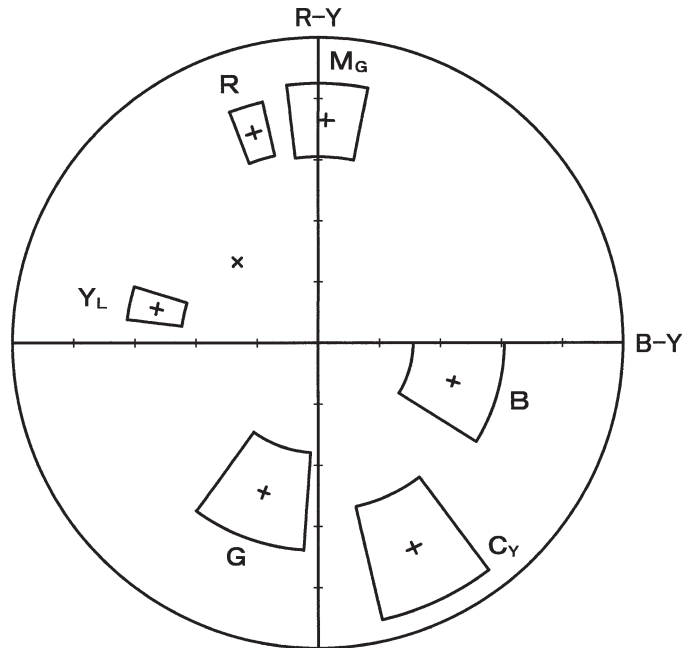

CCD-TR618E/TR718E/TR728E/TRV49E/
TRV58E/TRV59E/TRV78E/TRV98E



**CCD-TR618/TR618E/TR718E/TR728E/TR818/TRV49/TRV49E/TRV58/
TRV58E/TRV59E/TRV68/TRV78/TRV78E/TRV88/TRV98/TRV98E**